



Hewlett Packard
Enterprise

HPE ProLiant ML350 Gen9 Server

User Guide

Abstract

This document is for the person who installs, administers, and troubleshoots servers and storage systems. Hewlett Packard Enterprise assumes you are qualified in the servicing of computer equipment and trained in recognizing hazards in products with hazardous energy levels.

Part Number: 781896-005
October 2016
Edition: 5

Copyright 2014, 2016 Hewlett Packard Enterprise Development LP

The information contained herein is subject to change without notice. The only warranties for Hewlett Packard Enterprise products and services are set forth in the express warranty statements accompanying such products and services. Nothing herein should be construed as constituting an additional warranty. Hewlett Packard Enterprise shall not be liable for technical or editorial errors or omissions contained herein.

Links to third-party websites take you outside the Hewlett Packard Enterprise website. Hewlett Packard Enterprise has no control over and is not responsible for information outside the Hewlett Packard Enterprise website.

Linux® is the registered trademark of Linus Torvalds in the U.S. and other countries.

Microsoft® and Windows® are either registered trademarks or trademarks of Microsoft Corporation in the United States and/or other countries.

microSD is a trademark or a registered trademark of SD-3C in the United States, other countries or both.

Red Hat® is a registered trademark of Red Hat, Inc. in the United States and other countries.

VMware® is a registered trademark of trademark of VMware, Inc. in the United States and/or other jurisdictions.

Contents

Component identification	7
Front panel components.....	7
Front panel LEDs and buttons.....	10
UID button functionality	11
Front panel LEDs power fault codes	11
Rear panel components	11
Rear panel LEDs	12
Systems Insight Display LEDs	13
Systems Insight Display LED combinations	14
System board components.....	15
NMI functionality	16
DIMM slots.....	17
System maintenance switch	17
Power supply backplane connectors	18
Device numbering	19
Hot-plug drive LED definitions.....	26
NVMe SSD components	27
Hot-plug fans	28
Operations	30
Powering up the server	30
Power down the server.....	30
Remove the security bezel (optional).....	31
Remove the tower bezel.....	31
Install the tower bezel.....	31
Remove the access panel	32
Install the access panel	33
Extend the server from the rack	34
Remove the air baffle	34
Install the air baffle	35
Remove a fan	36
Remove the fan cage	37
Install the fan cage	38
Remove the optical drive.....	39
Remove a drive cage blank.....	39
Using the Systems Insight Display	41
Setup	43
Optional services.....	43
Optimum environment	43
Space and airflow requirements.....	43
Temperature requirements	44
Power requirements	44
Electrical grounding requirements	45
Connecting a DC power cable to a DC power source	45
Server warnings and cautions.....	46
Identifying the contents of the server shipping carton	46
Installing hardware options.....	47
Setting up a tower server	47
Installing the server into a rack.....	48
Powering on and selecting boot options.....	48
Installing the operating system.....	49
Registering the server	49
Hardware options installation.....	50

Product QuickSpecs	50
Introduction	50
Security bezel option	50
Tower to rack conversion	50
Systems Insight Display option	56
Drive options	58
Drive installation guidelines	58
Removing a drive blank	59
Installing a hot-plug SAS or SATA drive	59
Removing a hot-plug SAS or SATA drive	60
Installing NVMe drives	60
Storage controller options	62
Installing a Flexible Smart Array Controller option	62
Installing an HPE Host Bus Adapter	65
Installing a storage controller and FBWC module option	69
Installing an HPE Smart Storage Battery	74
Installing a SAS Expander option	76
Installing a second SAS Expander card	80
SAS Expander configurations	83
Installing the HPE NVMe Express bay	83
Optical drive option	87
Processor option	90
Processor installation cautions	90
Installing a second processor	91
Redundant fan option	95
Memory options	97
Memory-processor compatibility information	97
SmartMemory	99
Memory subsystem architecture	99
Single-, dual-, and quad-rank DIMMs	100
DIMM identification	100
Memory configurations	101
General DIMM slot population guidelines	102
Identifying the processor type	103
Installing a DIMM	103
SFF media cage option	104
LFF media cage option	108
GPU power cable option	111
Eight-bay SFF drive cage option	116
Eight-bay LFF drive backplane option	119
M.2 SSD enablement board option	121
Installing an M.2 SSD enablement board	121
Installing an SSD module	122
Dual 8Gb microSD Enterprise Midline USB device	123
Power supply options	124
Hot-plug power supply module	124
x4 Redundant Power Supply backplane option	125
Power supply modes	129
Selecting the power supply mode	129
System health and power redundancy	129
HPE Trusted Platform Module option	130
Installing the Trusted Platform Module and security rivet	131
Retaining the recovery key/password	133
Enabling the Trusted Platform Module	133
Cabling	134
Cabling overview	134
Media device data cabling	134
Optical device cabling	135
Front I/O module cabling	136
Systems Insight Display cabling	137

FBWC module backup power cabling	137
HPE Smart Storage Battery cabling	139
Power supply backplane cabling	139
Drive cage power cabling	141
Embedded SATA cabling	143
HPE Flexible Smart Array Controller Mini-SAS cabling	144
HPE Smart Array Controller Mini-SAS Y-cabling	144
SAS Expander cabling	146
Express bay cabling	148
M.2 SSD cabling.....	149
Software and configuration utilities	150
Server mode.....	150
Product QuickSpecs.....	150
HPE iLO	150
Active Health System	150
iLO RESTful API support.....	151
Integrated Management Log	152
Intelligent Provisioning	152
Intelligent Provisioning	152
Insight Diagnostics	153
Insight Diagnostics survey functionality.....	153
Erase Utility	153
Scripting Toolkit for Windows and Linux	153
Service Pack for ProLiant.....	154
Smart Update Manager	154
UEFI System Utilities.....	154
Using UEFI System Utilities.....	155
Flexible boot control	155
Restoring and customizing configuration settings	156
Secure Boot configuration	156
Embedded UEFI shell.....	156
Embedded Diagnostics option.....	157
iLO RESTful API support for UEFI	157
Re-entering the server serial number and product ID	157
Utilities and features.....	157
HPE Smart Storage Administrator.....	157
Automatic Server Recovery.....	158
USB support	158
USB support.....	158
Redundant ROM support.....	159
Keeping the system current.....	160
Updating firmware or System ROM.....	160
Drivers	161
Software and firmware.....	162
Operating System Version Support.....	162
Version control.....	162
Operating systems and virtualization software support for ProLiant servers.....	163
HPE Technology Service Portfolio	163
Change control and proactive notification	163
Troubleshooting	164
Troubleshooting resources.....	164
System battery replacement	165
Warranty and regulatory information.....	168
Warranty information	168
Regulatory information	168
Safety and regulatory compliance	168
Belarus Kazakhstan Russia marking.....	168
Turkey RoHS material content declaration.....	169

Ukraine RoHS material content declaration	169
Electrostatic discharge.....	170
Preventing electrostatic discharge	170
Grounding methods to prevent electrostatic discharge	170
Specifications.....	171
Environmental specifications.....	171
Server specifications	171
Power supply specifications	172
Hot-plug power supply calculations.....	172
Support and other resources	173
Accessing Hewlett Packard Enterprise Support.....	173
Information to collect	173
Accessing updates	173
Websites.....	173
Customer Self Repair	174
Remote support.....	181
Acronyms and abbreviations.....	182
Documentation feedback	187
Index	188

Component identification

Front panel components

- SFF model (tower orientation)

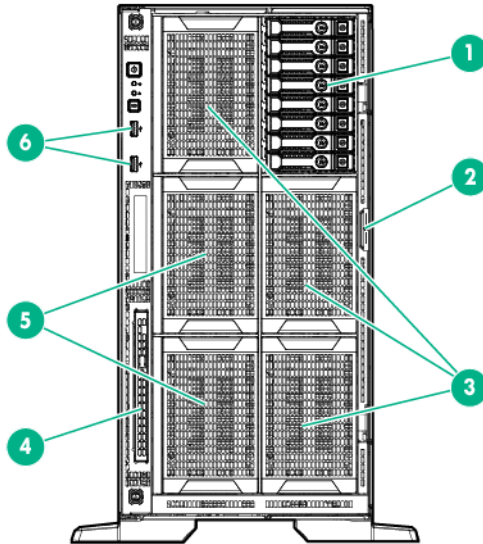

Item	Description
1	SFF SAS/SATA drives
2	Serial label pull tab*
3	Drive cage bays
4	Optical drive bay
5	Media/drive cage bays
6	USB 2.0 connectors (2)

*The serial label pull tab is double-sided. One side shows the server serial number, and the other side shows the default iLO account information. The same information is printed on a label attached to the chassis.

- SFF model (rack orientation)

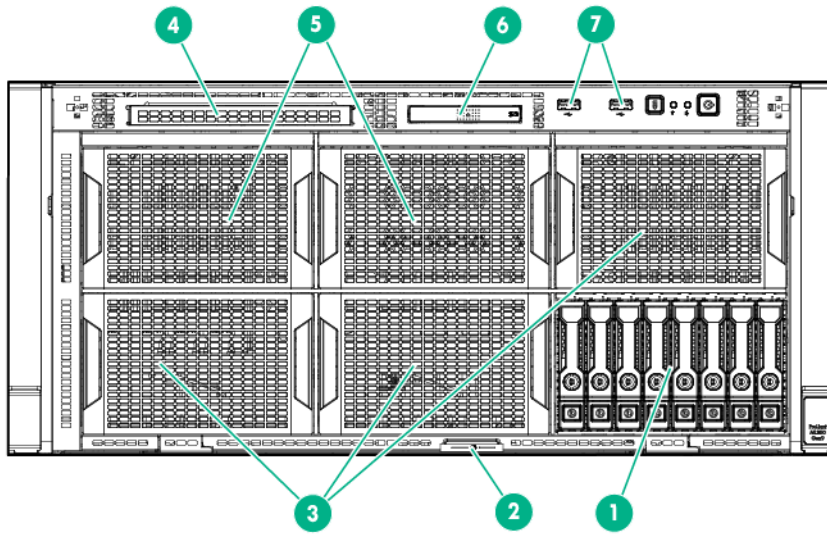

Item	Description
1	SFF SAS/SATA drives
2	Serial label pull tab*
3	Drive cage bays
4	Optical drive bay
5	Media/drive cage bays
6	Systems Insight Display bay
7	USB 2.0 connectors (2)

*The serial label pull tab is double-sided. One side shows the server serial number, and the other side shows the default iLO account information. The same information is printed on a label attached to the chassis.

- LFF model (tower orientation)

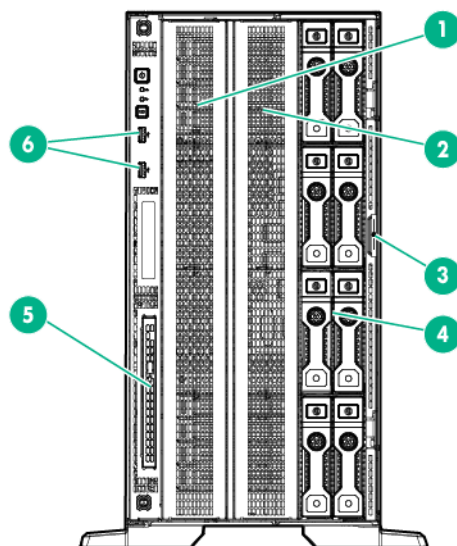

Item	Description
1	Media/drive cage bay
2	Drive cage bay
3	Serial label pull tab*
4	LFF SAS/SATA drives
5	Optical drive bay
6	USB 2.0 connectors (2)

*The serial label pull tab is double-sided. One side shows the server serial number, and the other side shows the default iLO account information. The same information is printed on a label attached to the chassis.

- LFF model (rack orientation)

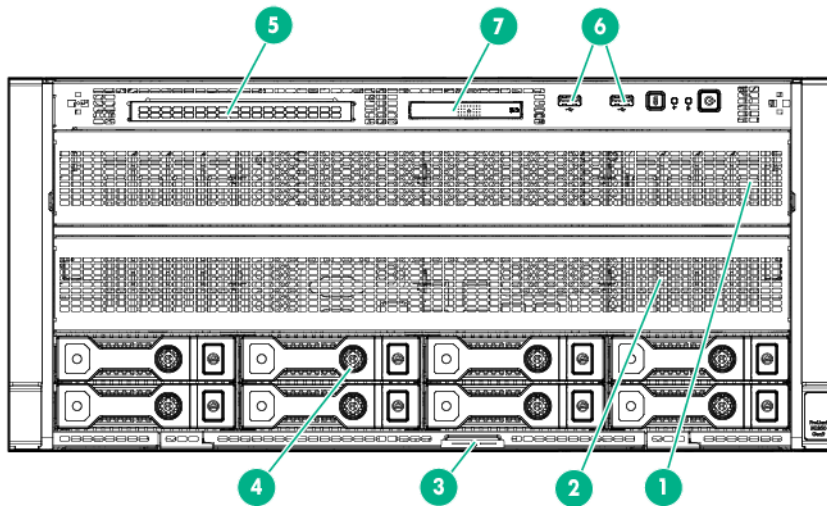

Item	Description
1	Media/drive cage bay
2	Drive cage bay
3	Serial label pull tab*
4	LFF SAS/SATA drives
5	Optical drive bay
6	USB 2.0 connectors (2)
7	Systems Insight Display bay

*The serial label pull tab is double-sided. One side shows the server serial number, and the other side shows the default iLO account information. The same information is printed on a label attached to the chassis.

For more information on box and drive numbering, see "Device numbering (on page 19)."

Front panel LEDs and buttons

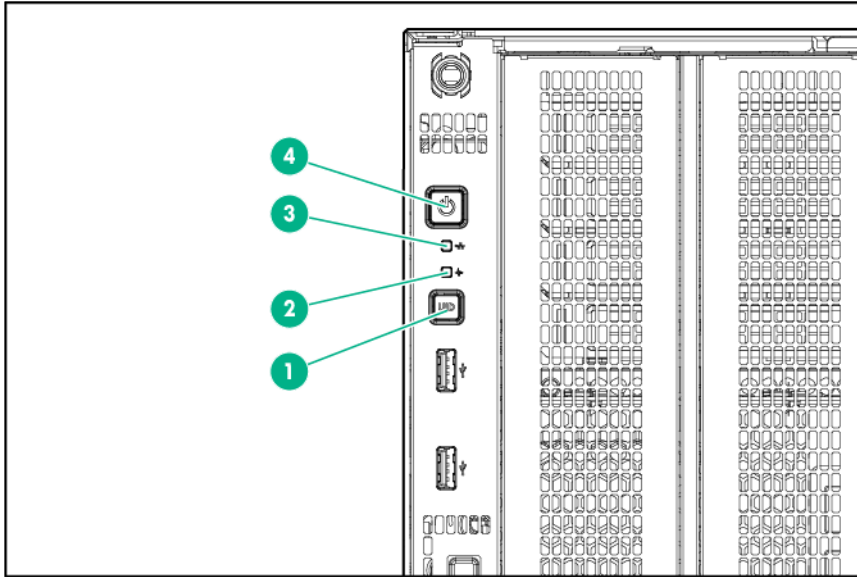

Item	Description	Status
1	UID button/LED	<p>Solid blue = Activated</p> <p>Flashing blue:</p> <ul style="list-style-type: none"> • 1 flash per second = Remote management or firmware upgrade in progress • 4 flashes per second = iLO manual reboot sequence initiated • 8 flashes per second = iLO manual reboot sequence in progress <p>Off = Deactivated</p>
2	Health LED	<p>Solid green = Normal</p> <p>Flashing green (1 flash per second) = iLO is rebooting</p> <p>Flashing amber = System degraded</p> <p>Flashing red (1 flash per second) = System critical</p> <p>If the health LED indicates a degraded or critical state, review the system IML ("Integrated Management Log" on page 152) or use iLO ("HPE iLO" on page 150) to review the system health status.</p>
3	NIC status LED	<p>Solid green = Link to network</p> <p>Flashing green (1 flash per second) = Network active</p> <p>Off = No network activity</p>
4	Power On/Standby button and system power LED	<p>Solid green = System on</p> <p>Flashing green (1 flash per second) = Performing power on sequence</p> <p>Solid amber = System in standby</p> <p>Off = No power present</p> <p>Facility power is not present, power cord is not attached, no power supplies are installed, power supply failure has occurred, or the front I/O cable is disconnected.</p>

When all four LEDs described in this table flash simultaneously, a power fault has occurred. For more information, see "Front panel LED power fault codes ("Front panel LEDs power fault codes" on page 11)."

UID button functionality

The UID button can be used to display the HPE ProLiant Pre-boot Health Summary when the server will not power on. For more information, see the *HPE iLO 4 User Guide* on the Hewlett Packard Enterprise website (<http://www.hpe.com/info/ilo/docs>).

Front panel LEDs power fault codes

The following table provides a list of power fault codes, and the subsystems that are affected. Not all power faults are used by all servers.

Subsystem	Front panel LED behavior
System board	1 flash
Processor	2 flashes
Memory	3 flashes
Riser board PCIe slots	4 flashes
FlexibleLOM	5 flashes
Removable HPE Flexible Smart Array controller/Smart SAS HBA controller	6 flashes
System board PCIe slots	7 flashes
Power backplane or storage backplane	8 flashes
Power supply	9 flashes

Rear panel components

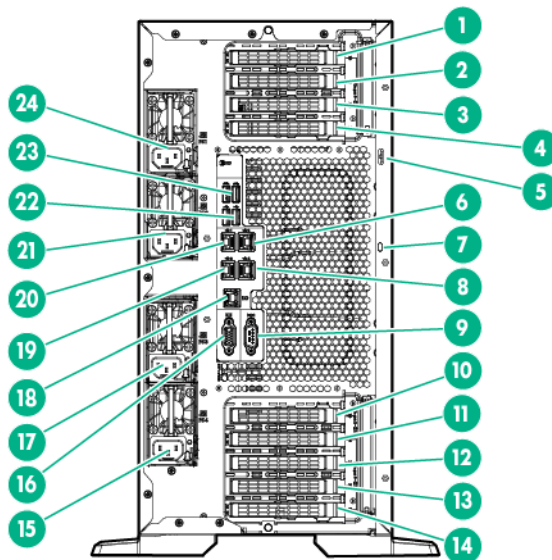

Item	Description
1	Slot 1 PCIe3 x16 (8, 4, 1) (processor 1)
2	Slot 2 PCIe3 x8 (4, 1) (processor 1)
3	Slot 3 PCIe3 x16 (16, 8, 4, 1) (processor 1)

Item	Description
4	Slot 4 PCIe3 x8 (4, 1) (processor 1)
5	Padlock hole
6	NIC connector 2
7	Kensington lock slot
8	NIC connector 4
9	Serial connector
10	Slot 5 PCIe2 x8 (4, 1) (processor 2)
11	Slot 6 PCIe3 x16 (16, 8, 4, 1) (processor 2)
12	Slot 7 PCIe3 x8 (4, 1) (processor 2)
13	Slot 8 PCIe3 x16 (16, 8, 4, 1) (processor 2)
14	Slot 9 PCIe3 x8 (4, 1) (processor 2)
15	Power supply 4
16	Video connector
17	Power supply 3
18	iLO connector
19	NIC connector 3
20	NIC connector 1
21	Power supply 2
22	USB 2.0 connectors (2)
23	USB 3.0 connectors (2)
24	Power supply 1

Rear panel LEDs

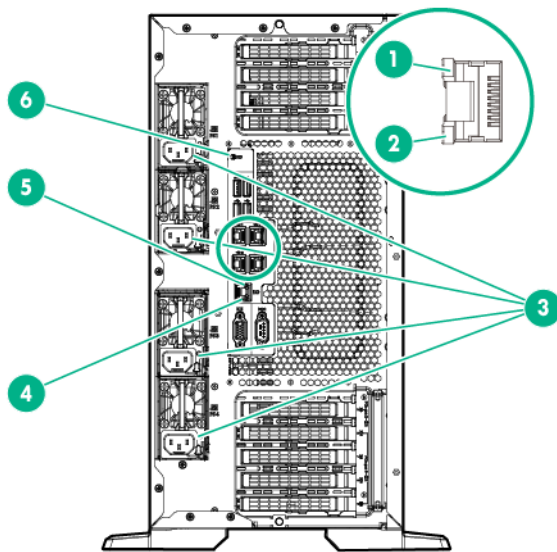

Item	Description	Status
1	NIC activity LED	Solid green = Link to network Flashing green = Network active Off = No network activity
2	NIC link LED	Green = Network link Off = No network link

Item	Description	Status
3	Power supply LED	Solid green = Normal Off = One or more of the following conditions exists: <ul style="list-style-type: none"> • Power is unavailable • Power supply failed • Power supply is in standby mode • Power supply error
4	iLO link LED	Green = Linked to network Off = No network connection
5	iLO activity LED	Green or flashing green = Network activity Off = No network activity
6	UID LED	Solid blue = Activated Flashing blue: <ul style="list-style-type: none"> • 1 flash per second = Remote management or firmware upgrade in progress • 4 flashes per second = iLO manual reboot sequence initiated • 8 flashes per second = iLO manual reboot sequence in progress Off = Deactivated

Systems Insight Display LEDs

The HPE SID LEDs represent the system board layout. To view the LEDs, see "Using the Systems Insight Display (on page 41)."

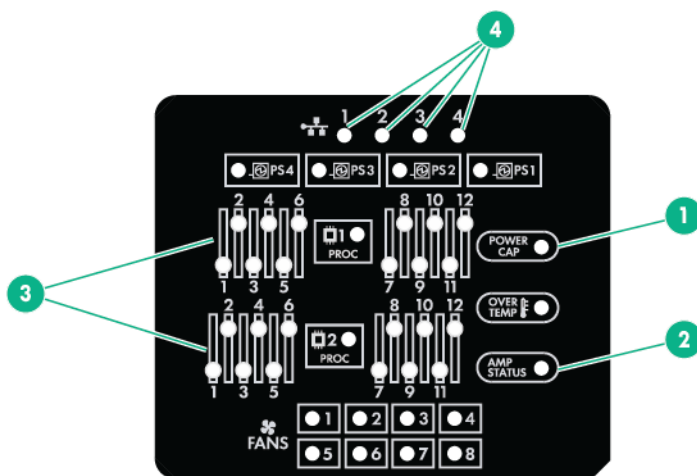

Item	Description	Status
1	Power cap	Green = Power cap applied Amber = Power not available Off = Standby on not configured
2	AMP Status	Green = AMP mode enabled Amber = Failover or invalid configuration Off = AMP mode disabled

Item	Description	Status
3	DIMM LEDs	Amber = DIMM error Off = Normal
4	NIC LED	Solid green = Link to network Flashing green (1 Hz/cycle per sec) = Network active Off = No network activity
	All other LEDs	Off = Normal On = Failed

Systems Insight Display LED combinations

When the health LED on the front panel illuminates either amber or red, the server is experiencing a health event. Combinations of illuminated SID LEDs, the system power LED, and the health LED indicate system status.

Systems Insight Display LED and color	Health LED	System power LED	Status
Processor (amber)	Red	Amber	One or more of the following conditions might exist: <ul style="list-style-type: none"> Processor in socket <i>X</i> has failed. Processor <i>X</i> is not installed in the socket. Processor <i>X</i> is unsupported. ROM detects a failed processor during POST.
Processor (amber)	Amber	Green	Processor in socket <i>X</i> is in a pre-failure condition.
DIMM (amber)	Red	Green	One or more DIMMs have failed.
DIMM (amber)	Amber	Green	DIMM in slot <i>X</i> is in a pre-failure condition.
Overtemperature (amber)	Amber	Green	The Health Driver has detected a cautionary temperature level.
Overtemperature (amber)	Red	Amber	The server has detected a hardware critical temperature level.
Fan (amber)	Amber	Green	Fan has failed or is missing, but still meets the minimum fan requirements.
Fan (amber)	Red	Green	Fan has failed or is missing and no longer meets the minimum fan requirements.
Power supply (amber)	Red	Amber	<ul style="list-style-type: none"> Only one power supply installed and in standby mode. Power supply fault. System board fault.
Power supply (amber)	Amber	Green	<ul style="list-style-type: none"> Redundant power supply is installed and only one power supply is functional. AC power cord is not plugged into redundant power supply. Redundant power supply fault. Power supply mismatch at POST or through hot-plug addition.
Power cap (off)	—	Amber	Standby
Power cap (green)	—	Flashing green	Waiting for power.

Systems Insight Display LED and color	Health LED	System power LED	Status
Power cap (flashing amber)	—	Amber	Power cap has been exceeded.
Power cap (green)	—	Green	Power is available.



IMPORTANT: If more than one DIMM slot LED is illuminated, further troubleshooting is required. Test each bank of DIMMs by removing all other DIMMs. Isolate the failed DIMM by replacing each DIMM in a bank with a known working DIMM.

System board components

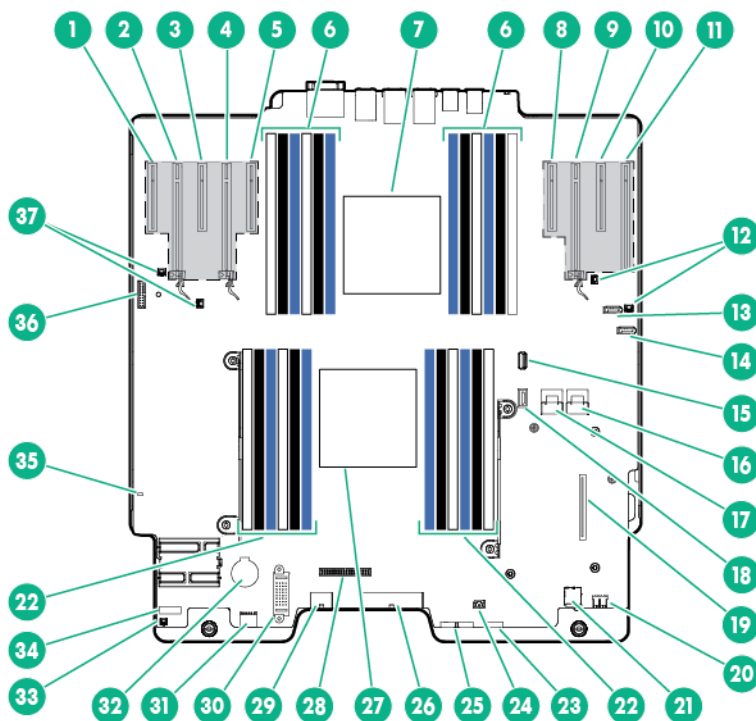

Item	Description
1	Slot9 PCIe3 x8 (4,1) (for processor 2)
2	Slot8 PCIe3 x16 (16,8,4,1) (for processor 2)
3	Slot7 PCIe3 x8 (4,1) (for processor 2)
4	Slot6 PCIe3 x16 (16,8,4,1) (for processor 2)
5	Slot5 PCIe2 x8 (4,1) (for processor 2)
6	DIMM slots for processor 1
7	Processor 1
8	Slot4 PCIe3 x8 (4,1) (for processor 1)
9	Slot3 PCIe3 x16 (16,8,4,1) (for processor 1)
10	Slot2 PCIe3 x8 (4,1) (for processor 1)
11	Slot1 PCIe3 x16 (8,4,1) (for processor 1)
12	Storage backup power connectors
13	SATA port 4

Item	Description
14	SATA port 5
15	Internal USB 3.0 connector
16	x4 SATA port 2
17	x4 SATA port 1
18	Internal USB 2.0 connector
19	Flexible Smart Array Controller connector
20	Internal USB tape drive connector
21	Micro SD card slot
22	DIMM slots for processor 2
23	Systems Insight Display connector
24	Ambient sensor cable connector
25	Front I/O connector
26	24-pin power supply connector
27	Processor 2
28	RPS connector
29	8-pin power supply connector
30	Fan cage power connector
31	Smart Storage Battery connector
32	System battery holder
33	Discovery service connector
34	System maintenance switch
35	NMI header
36	TPM connector
37	Storage backup power connectors

NMI functionality

An NMI crash dump creates a crash dump log before resetting a system which is not responding.

Crash dump log analysis is an essential part of diagnosing reliability problems, such as failures of operating systems, device drivers, and applications. Many crashes freeze a system, and the only available action for administrators is to restart the system. Resetting the system erases any information which could support problem analysis, but the NMI feature preserves that information by performing a memory dump before a system reset.

To force the system to invoke the NMI handler and generate a crash dump log, do one of the following:

- Use the iLO Virtual NMI feature.
- Short the NMI header ("[System board components](#)" on page 15).

For more information, see the Hewlett Packard Enterprise website (<http://www.hpe.com/support/NMI-CrashDump>).

DIMM slots

DIMM slots are numbered sequentially (1 through 12) for each processor. The supported AMP modes use the letter assignments for population guidelines.

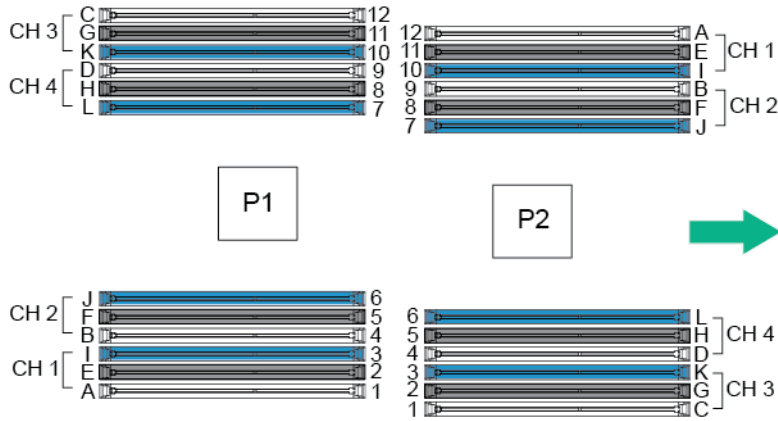

The arrow points to the front of the server.

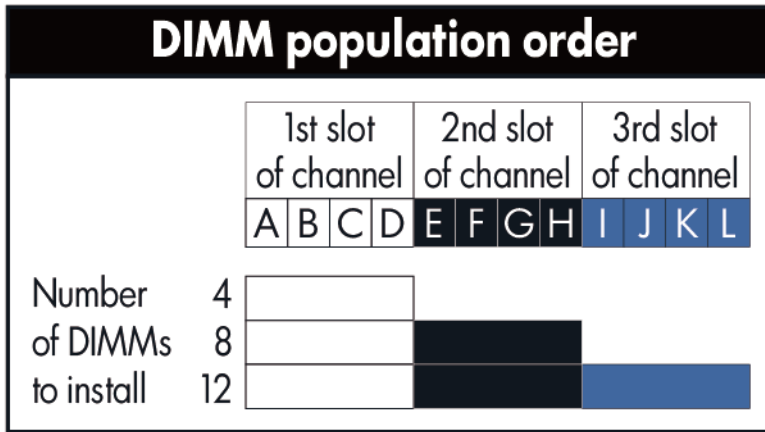

System maintenance switch

Position	Default	Function
S1	Off	Off = iLO security is enabled. On = iLO security is disabled.
S2	Off	Off = System configuration can be changed. On = System configuration is locked.
S3	Off	Reserved
S4	Off	Reserved

Position	Default	Function
S5	Off	Off = Power-on password is enabled. On = Power-on password is disabled.
S6	Off	Off = No function On = ROM reads system configuration as invalid.
S7	Off	Off = Set default boot mode to UEFI. On = Set default boot mode to legacy.
S8	—	Reserved
S9	—	Reserved
S10	—	Reserved
S11	—	Reserved
S12	—	Reserved

You can access the redundant ROM by setting S1, S5, and S6 to On.

When the system maintenance S6 switch is set to the On position, the system will erase all system configuration settings from both CMOS and NVRAM on the next reboot. Clearing CMOS, NVRAM, or both delete configuration information. Be sure to configure the server properly to prevent data loss.

Power supply backplane connectors

- x2 power supply backplane

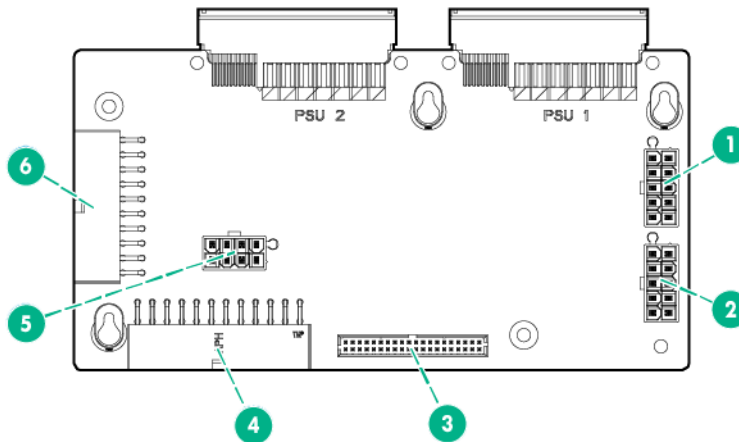

Connector	Description
1	GPU Power cable connector (optional)
2	GPU Power cable connector (optional)
3	2x20-pin System board signal cable connector
4	2x12-pin System board power cable connector
5	2x4-pin System board power cable connector
6	Drive boxes 1, 2, 3 (LFF configuration) or 4, 5, 6 (SFF configuration) backplane power cable connector

- x4 power supply backplane

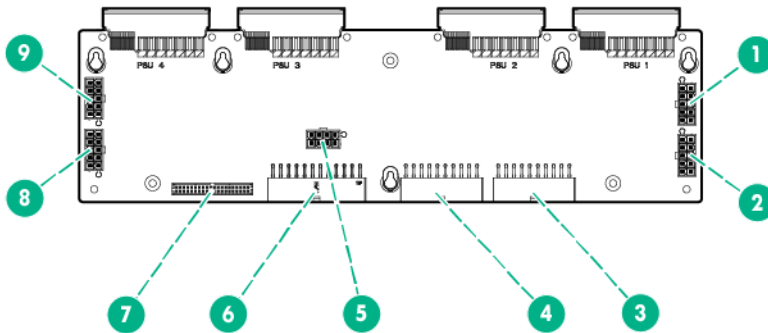

Connector	Description
1	GPU Power cable connector (optional)
2	GPU Power cable connector (optional)
3	Drive boxes 1,2,3 backplane power cable connector
4	Drive boxes 4,5,6 backplane power cable connector
5	2x4 System board power cable connector
6	2x12 System board power cable connector
7	2x20 System board signal cable connector
8	GPU Power cable connector (optional)
9	GPU Power cable connector (optional)

Device numbering

With optional drive cages installed, the server supports up to 48 SFF drives or up to 24 LFF drives. The server does not support mixing SFF and LFF drives.

Hewlett Packard Enterprise recommends that you populate drive bays starting with the lowest SAS or SATA device number. Drives are numbered from left to right or bottom to top in each component box.

- **48 SFF drives**

- Tower orientation

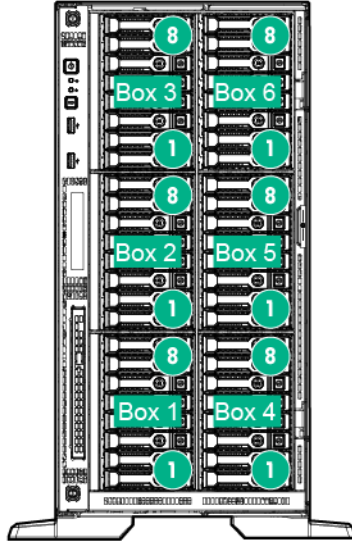

- Rack orientation

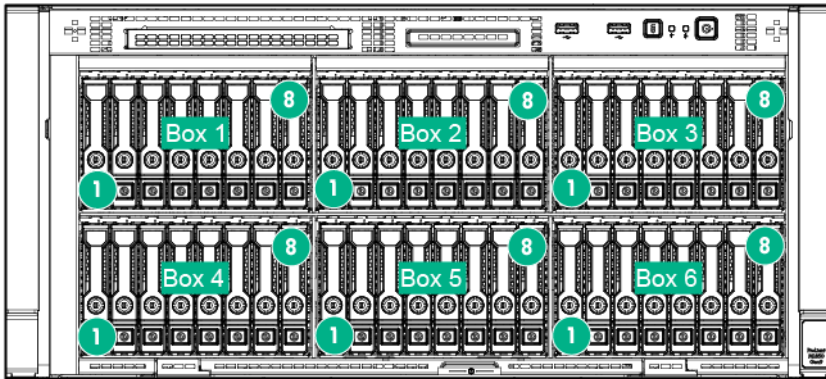

- 24 LFF drives

- Tower orientation

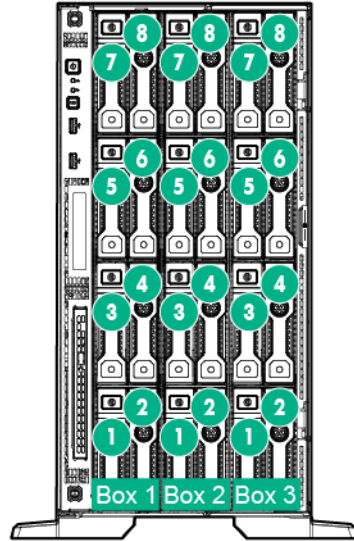

- Rack orientation

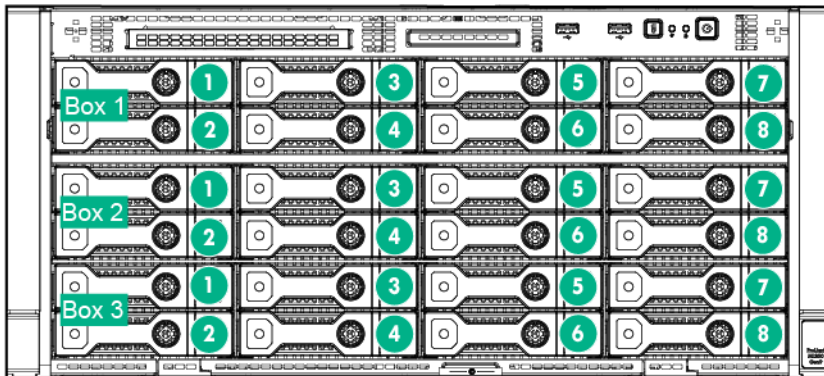

- SAS Expander
 - One SAS expander configuration with SFF drives

— Tower orientation

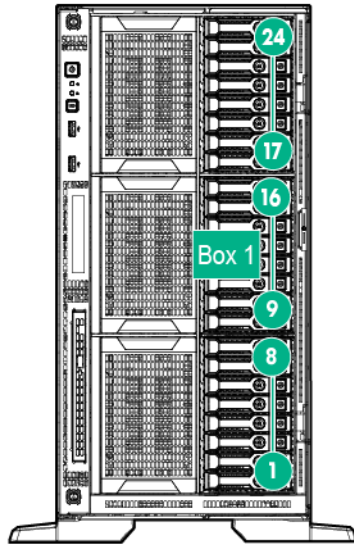

— Rack orientation

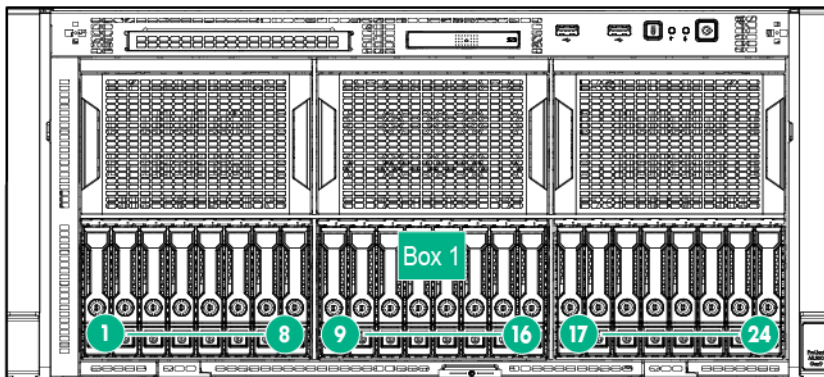

- One SAS expander configuration with LFF drives

— Tower orientation

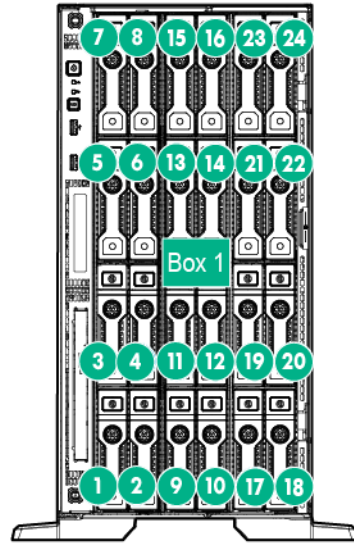

— Rack orientation

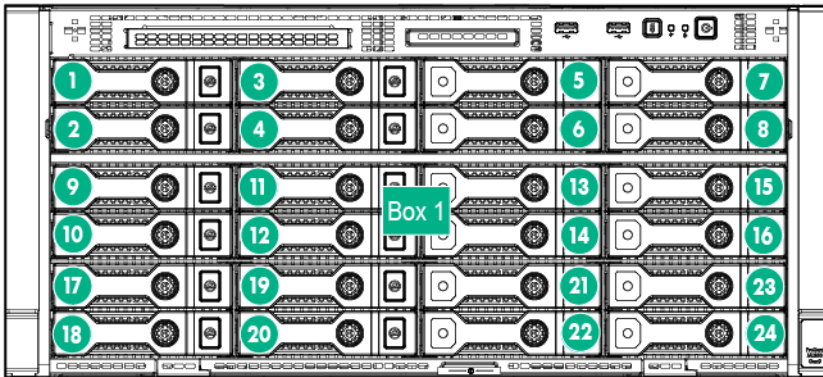

- Two SAS expanders configuration with SFF drives

— Tower orientation

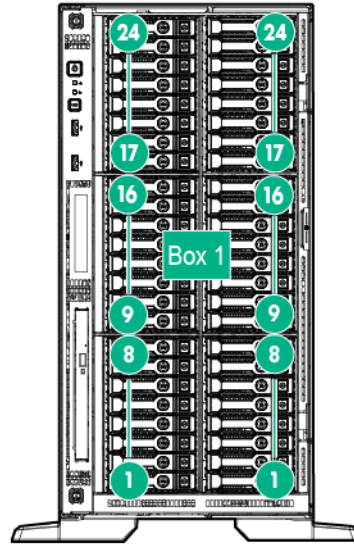

— Rack orientation

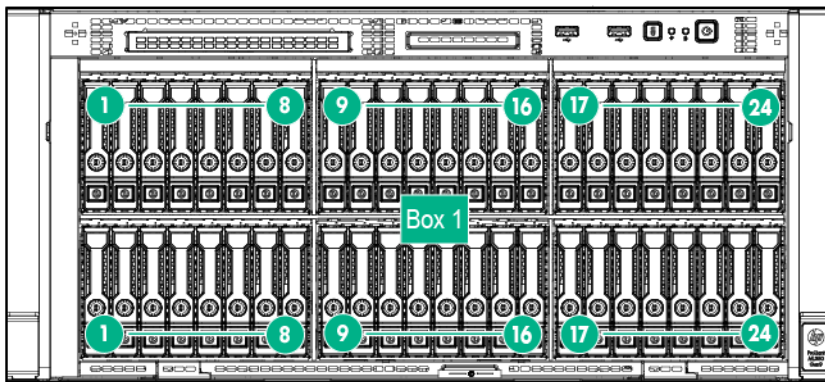

- Media bay

- SFF Media bay and 32 SFF drives

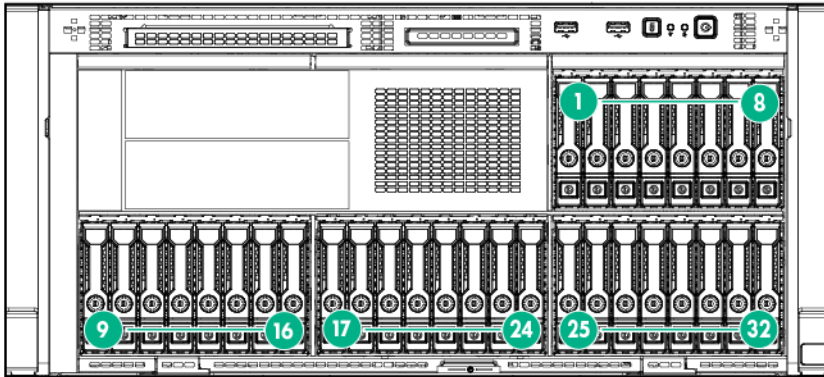

- LFF Media bay and 16 LFF drives

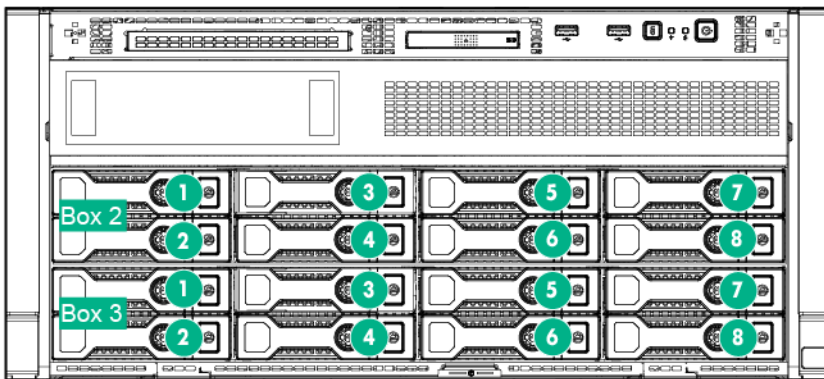

- NVMe SSD Express bay
 - NVMe SSD Express bay installed in box 1 and 8 SFF drives

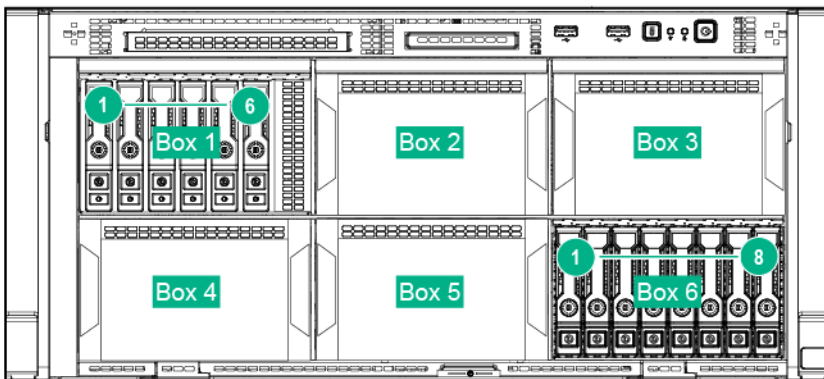

- o NVMe SSD Express bay installed in box 4 and 8 SFFdrives

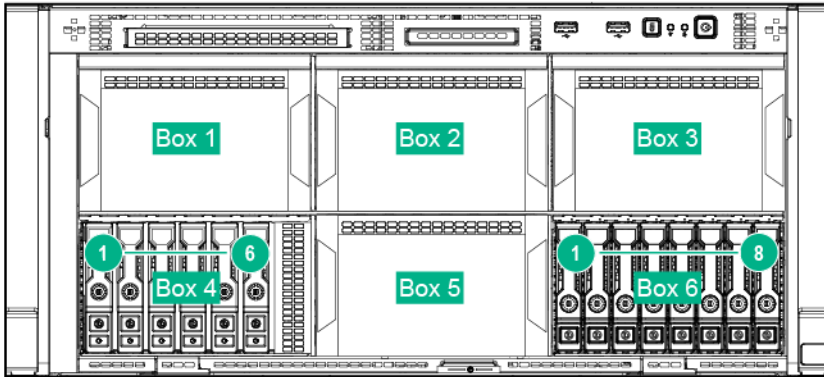

- o NVMe SSD Express bay and 40 SFF drives

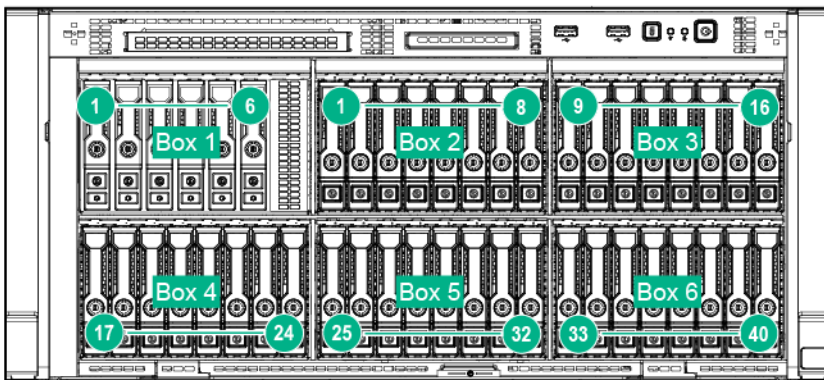

Hot-plug drive LED definitions

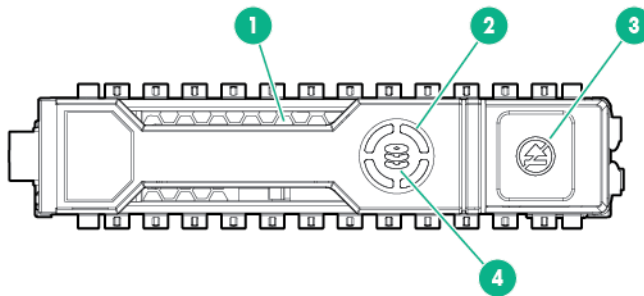

Item	LED	Status	Definition
1	Locate	Solid blue	The drive is being identified by a host application.
		Flashing blue	The drive carrier firmware is being updated or requires an update.
2	Activity ring	Rotating green	Drive activity.
		Off	No drive activity.
3	Do not remove	Solid white	Do not remove the drive. Removing the drive causes one or more of the logical drives to fail.

Item	LED	Status	Definition
		Off	Removing the drive does not cause a logical drive to fail.
4	Drive status	Solid green	The drive is a member of one or more logical drives.
		Flashing green	The drive is rebuilding or performing a RAID migration, strip size migration, capacity expansion, or logical drive extension, or is erasing.
		Flashing amber/green	The drive is a member of one or more logical drives and predicts the drive will fail.
		Flashing amber	The drive is not configured and predicts the drive will fail.
		Solid amber	The drive has failed.
		Off	The drive is not configured by a RAID controller.

The blue Locate LED is behind the release lever and is visible when illuminated.



IMPORTANT: The Dynamic Smart Array B140i Controller is only available in UEFI Boot Mode. It cannot be enabled in Legacy BIOS Boot Mode. If the B140i controller is disabled, drives connected to the system board Mini-SAS connectors operate in AHCI or Legacy mode. Under this condition:

- The drives cannot be a part of a hardware RAID or a logical drive.
- The Locate, Drive status, and Do not remove LEDs of the affected drives are disabled.

Use BIOS/Platform Configuration (RBSU) in the UEFI System Utilities (on page 154) to enable or disable the B140i controller (System Configuration → BIOS/Platform Configuration (RBSU) → System Options → SATA Controller Options → Embedded SATA Configuration).

NVMe SSD components

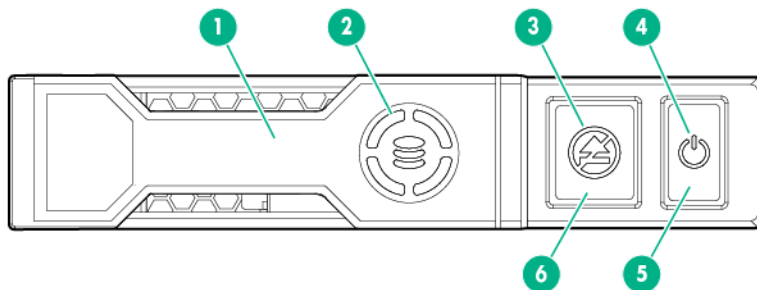

Item	Component	Status	Definition
1	Release lever	—	Ejects the NVMe drive carrier from the cage.
2	Activity ring LED	Rotating green	Drive activity
		Off	No drive activity
3	Do Not Remove LED	Solid white	Drive is powered on, and configured in system. Do not remove the drive.
		Flashing white	Ejection request pending. Do not remove the drive.
		Off	Drive removed from the PCIe bus, and can be ejected.
4	Power LED	Solid green	Drive is powered on, and configured in system. Do not remove the drive.
		Flashing green	Ejection request pending. Do not remove the drive.
		Off	Drive removed from the PCIe bus, and can be ejected.
5	Power button	—	Momentary press to request drive removal from PCIe bus and ejection. Drive removal request can be denied by operating system.

Item	Component	Status	Definition
6	Do Not Remove button	—	Releases the release lever for removal and insertion.

Upon NVMe SSD insertion, an LED initiation sequence will be visible - lighting each LED in the carrier in sequence from left to right. The sequence will cycle until the drive is recognized by the system. When the SSD is recognized by the system - the Do Not Remove LED will be solid white and the Power LED will be solid green.

Hot-plug fans

The server supports redundant hot-plug fans to provide proper airflow to the system when a primary fan fails.

CAUTION: To avoid damage to server components, a fan or fan blank must always be installed in fan bay 1.

CAUTION: To avoid damage to the equipment, do not operate the server for extended periods of time if the server does not have the optimal number of fans installed. Although the server might boot, Hewlett Packard Enterprise does not recommend operating the server without the required fans installed and operating.

Fan numbering

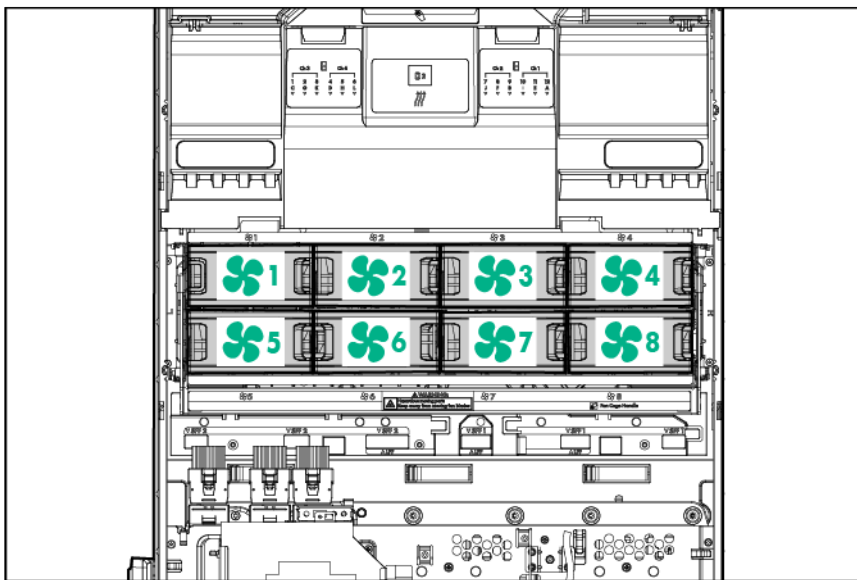

Fan population rules

The following table lists the valid fan configurations.

Configuration	Fan 1	Fan 2	Fan 3	Fan 4	Fan 5	Fan 6	Fan 7	Fan 8
Single processor – Non-Redundant	Fan blank	Fan	Fan	Fan	empty	empty	empty	empty
Dual processor – Non-Redundant	Fan	Fan	Fan	Fan	empty	empty	empty	empty
Single processor - Redundant	Fan blank	Fan	Fan	Fan	empty	Fan	Fan	Fan
Dual processor - Redundant	Fan	Fan	Fan	Fan	Fan	Fan	Fan	Fan

For a single-processor redundant configuration, six fans and one blank is required in specific fan bays for redundancy. A fan failure causes a loss of redundancy. A second fan failure causes an orderly shutdown of the server.

Installing more than the required number of fans in a single-processor configuration is not a supported configuration.

For a dual-processor redundant configuration, all fans are required for redundancy. A fan failure causes a loss of redundancy. A second fan failure causes an orderly shutdown of the server.

The server supports variable fan speeds. The fans operate at minimum speed until a temperature change requires a fan speed increase to cool the server. The server shuts down during the following temperature-related scenarios:

1. At POST and in the OS, iLO performs an orderly shutdown if a cautionary temperature level is detected. If the server hardware detects a critical temperature level before an orderly shutdown occurs, the server performs an immediate shutdown.
2. When the Thermal Shutdown feature is disabled in RBSU, iLO does not perform an orderly shutdown when a cautionary temperature level is detected. Disabling this feature does not disable the server hardware from performing an immediate shutdown when a critical temperature level is detected.



CAUTION: A thermal event can damage server components when the Thermal Shutdown feature is disabled in RBSU.

Operations

Powering up the server

To power up the server, press the Power On/Standby button.

Power down the server

Before powering down the server for any upgrade or maintenance procedures, perform a backup of critical server data and programs.



IMPORTANT: When the server is in standby mode, auxiliary power is still being provided to the system.

To power down the server, use one of the following methods:

- Press and release the Power On/Standby button.
This method initiates a controlled shutdown of applications and the OS before the server enters standby mode.
- Press and hold the Power On/Standby button for more than 4 seconds to force the server to enter standby mode.
This method forces the server to enter standby mode without properly exiting applications and the OS. If an application stops responding, you can use this method to force a shutdown.
- Use a virtual power button selection through iLO.
This method initiates a controlled remote shutdown of applications and the OS before the server enters standby mode.

Before proceeding, verify that the server is in standby mode by observing that the system power LED is amber.

Remove the security bezel (optional)

Unlock the security bezel, press the latch on the security bezel, and then remove the security bezel.

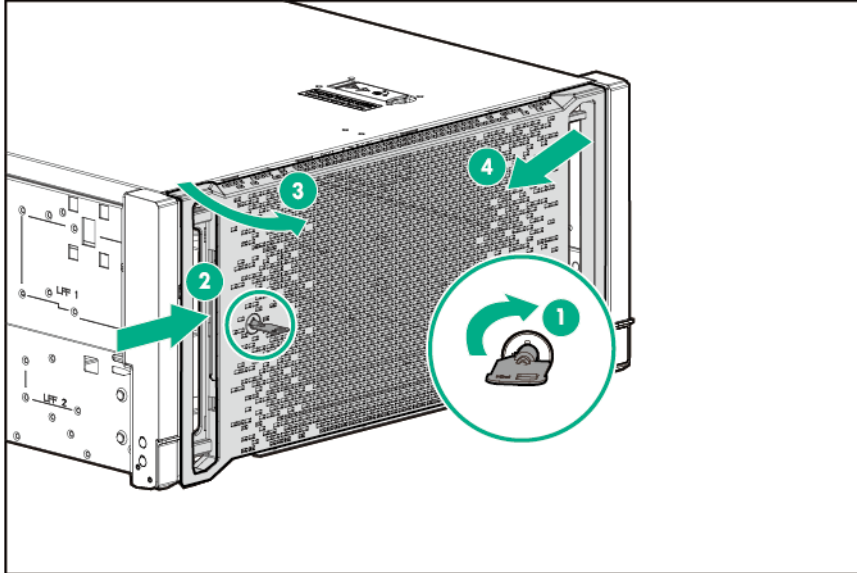

Remove the tower bezel

The tower configuration server has a removable bezel that must be unlocked and opened before accessing the drives. The bezel must be kept closed during normal server operations.

1. Using the key provided with the server, unlock the bezel with a clockwise turn.
2. Open the bezel.
3. Detach the bezel from the hinges to completely remove it from the server.

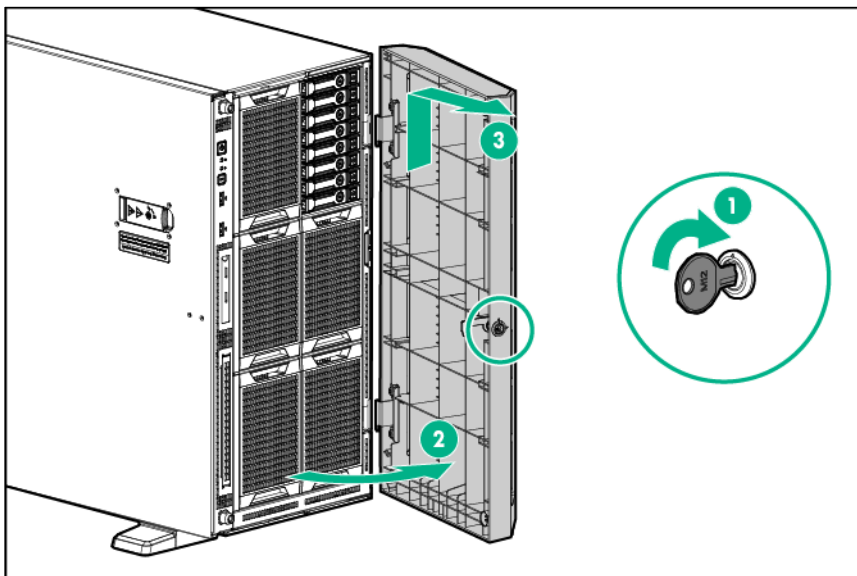

Install the tower bezel

1. Insert the bezel.

2. Close the bezel.
3. Using the key provided with the server, lock the bezel with a counterclockwise turn.

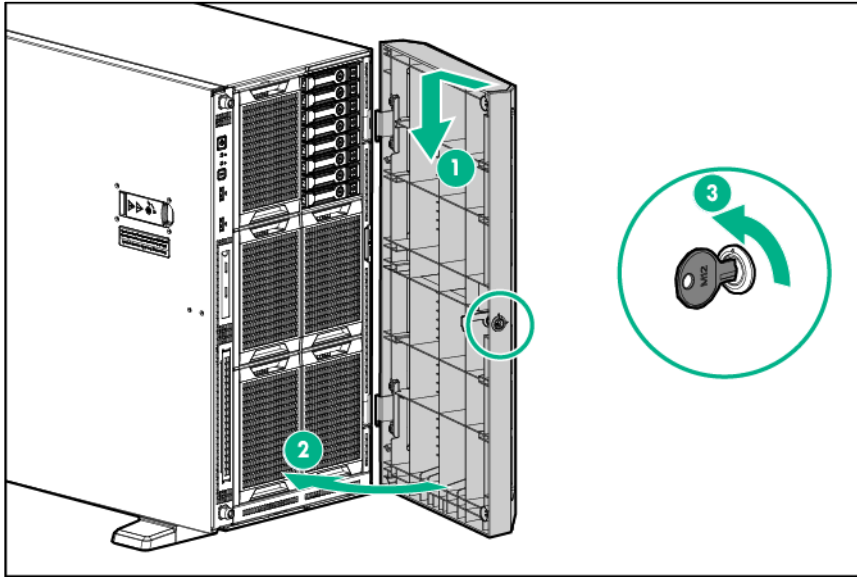

Remove the access panel

- ⚠ **WARNING:** To reduce the risk of personal injury from hot surfaces, allow the drives and the internal system components to cool before touching them.
- ⚠ **CAUTION:** To prevent damage to electrical components, take the appropriate anti-static precautions before beginning any installation, removal, or replacement procedure. Improper grounding can cause electrostatic discharge.
- ⚠ **CAUTION:** Do not operate the server for long periods with the access panel open or removed. Operating the server in this manner results in improper airflow and improper cooling that can lead to thermal damage.

To remove the component:

1. Do one of the following:
 - For tower models, open and remove the tower bezel ("[Remove the tower bezel](#)" on page 31).
 - For rack models, if installed, remove the security bezel ("[Remove the security bezel \(optional\)](#)" on page 31).
2. Power down the server (on page 30).
3. Remove all power:
 - a. Disconnect each power cord from the power source.
 - b. Disconnect each power cord from the server.
4. Do one of the following:
 - For tower models, place the server on a flat, level surface with the access panel facing up.
 - For rack models, extend the server from the rack (on page 34).
5. If a Kensington security cable is installed, disconnect it from the rear panel. See the security cable documentation for instructions.

6. Open the access panel latch, slide the access panel to the rear of the chassis, and then remove the access panel.

If the access panel latch is locked, use a T-15 Torx screwdriver to unlock the latch.

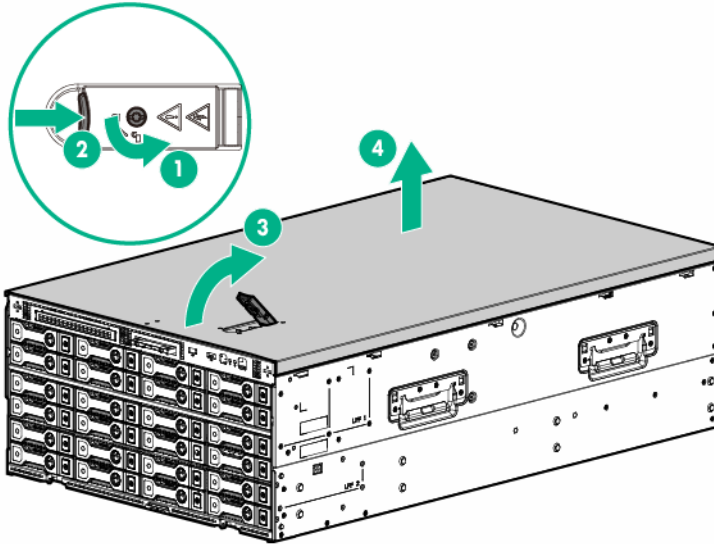

Install the access panel

1. Place the access panel on top of the server with the hood latch open. Allow the panel to extend past the rear of the server approximately 1.25 cm (0.5 inch).
2. Push down on the hood latch. The access panel slides to a closed position.
3. Use a T-15 Torx screwdriver to tighten the security screw on the hood latch.

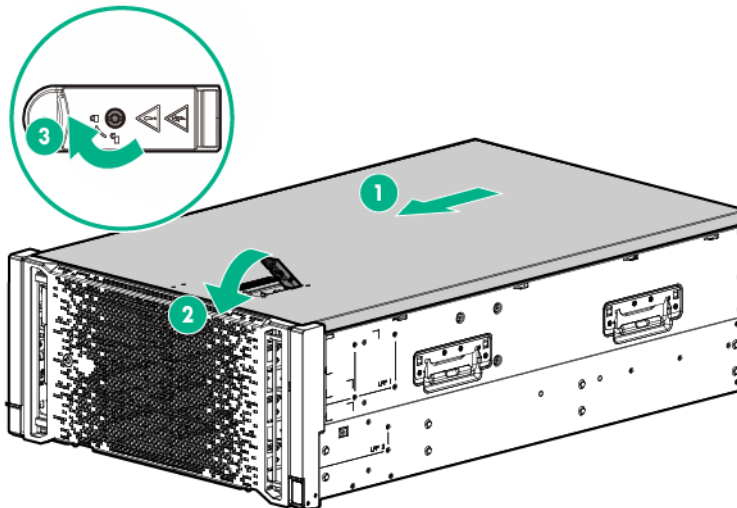

4. If the server is in a tower configuration, return the server to an upright position.
5. If the server is in a rack configuration, slide the server into the rack.
6. If a Kensington security cable was removed, connect it to the rear panel. See the security cable documentation for instructions.
7. Connect each power cord to the server.
8. Connect each power cord to the power source.

9. Power up the server ("Powering up the server" on page 30).
10. Do one of the following:
 - o For tower models, install the tower bezel (on page 31).
 - o For rack models, if removed, install the security bezel ("Security bezel option" on page 50).

Extend the server from the rack

WARNING: To reduce the risk of personal injury or equipment damage, be sure that the rack is adequately stabilized before extending a component from the rack.

1. Remove the security bezel ("Remove the security bezel (optional)" on page 31).
2. Power down the server (on page 30).
3. Remove all power:
 - a. Disconnect each power cord from the power source.
 - b. Disconnect each power cord from the server.
4. Loosen the screws from the latch ears and release the latches on each side of the server.
5. Extend the server from the rack.

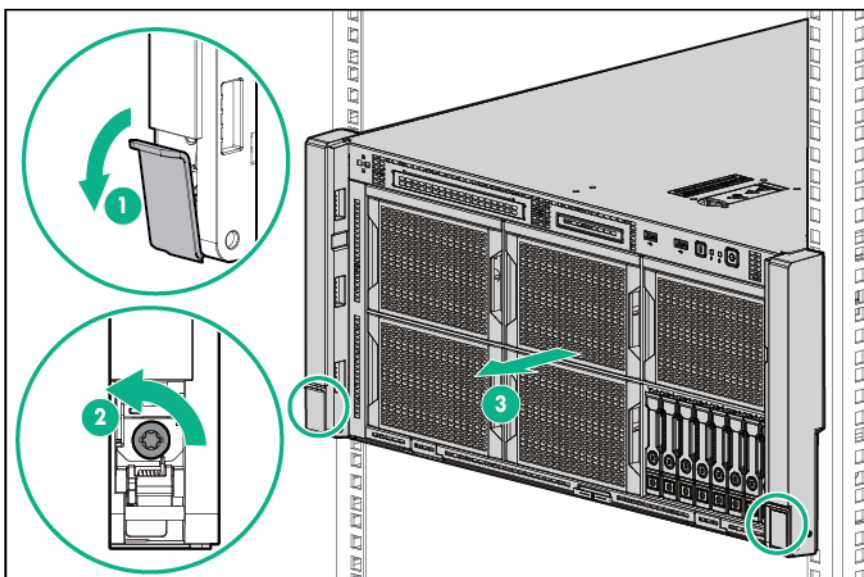

6. After completing the maintenance procedure, slide the server back into the rack, and then press the server firmly into the rack to secure it in place.

WARNING: To reduce the risk of personal injury, be careful when pressing the server rail-release latches and sliding the server into the rack. The sliding rails could pinch your fingers.

Remove the air baffle

CAUTION: For proper cooling, do not operate the server without the access panel, baffles, expansion slot covers, or blanks installed. If the server supports hot-plug components, minimize the amount of time the access panel is open.

To remove the component:

1. Do one of the following:

- For tower models, open and remove the tower bezel ("[Remove the tower bezel](#)" on page 31).
- For rack models, if installed, remove the security bezel ("[Remove the security bezel \(optional\)](#)" on page 31).
- 2. Power down the server (on page 30).
- 3. Remove all power:
 - a. Disconnect each power cord from the power source.
 - b. Disconnect each power cord from the server.
- 4. Do one of the following:
 - For tower models, place the server on a flat, level surface with the access panel facing up.
 - For rack models, extend the server from the rack (on page 34).
- 5. Remove the access panel (on page 32).
- 6. Remove the air baffle.

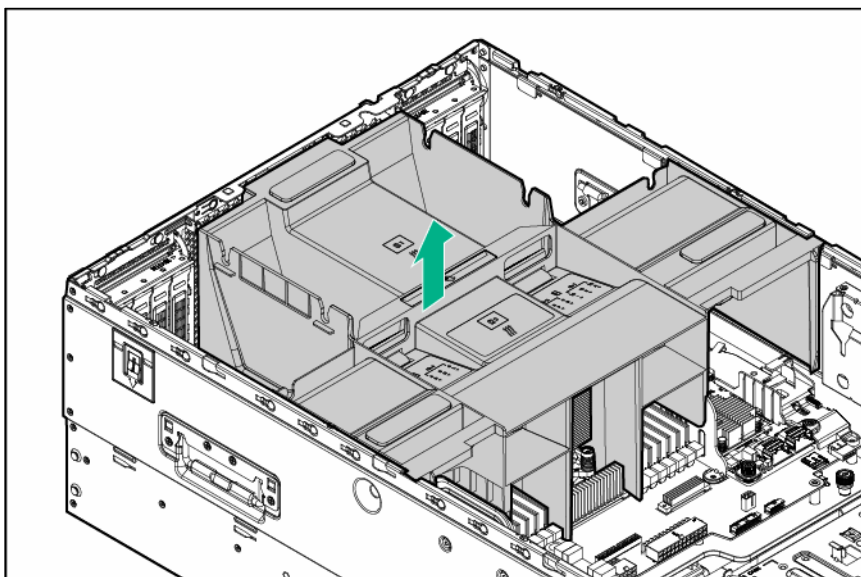

Install the air baffle

- △ **CAUTION:** For proper cooling, do not operate the server without the access panel, baffles, expansion slot covers, or blanks installed. If the server supports hot-plug components, minimize the amount of time the access panel is open.

To install the component:

1. Install the air baffle.

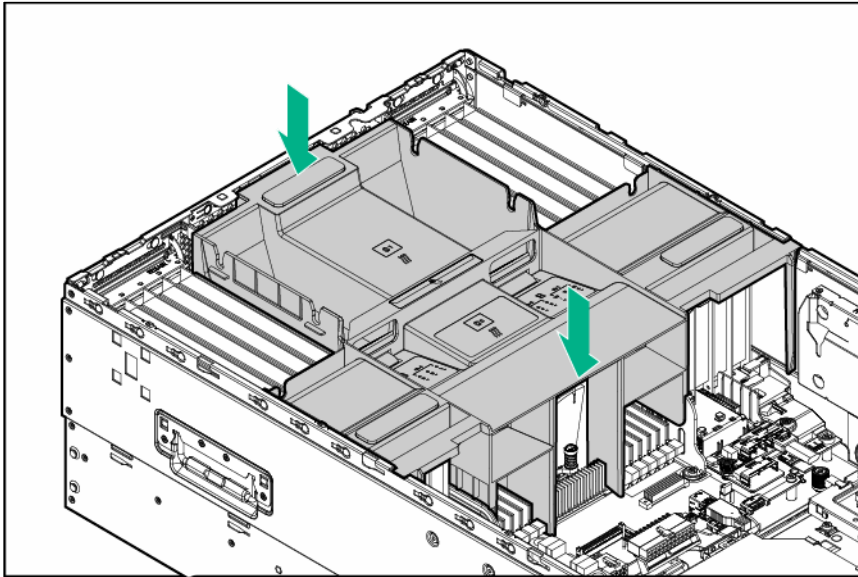

2. Install the access panel (on page 33).
3. Do one of the following:
 - o If the server is in a tower configuration, return the server to an upright position.
 - o If the server is in a rack configuration, slide the server into the rack.
4. Connect each power cord to the server.
5. Connect each power cord to the power source.
6. Power up the server ("[Powering up the server](#)" on page 30).
7. Do one of the following:
 - o For tower models, install the tower bezel (on page 31).
 - o For rack models, install the security bezel ("[Security bezel option](#)" on page 50)

Remove a fan



CAUTION: To prevent improper cooling and thermal damage, do not operate the server unless all bays are populated with either a component or a blank.

To remove the component:

1. Do one of the following:
 - o For tower models, open and remove the tower bezel ("[Remove the tower bezel](#)" on page 31).
 - o For rack models, if installed, remove the security bezel ("[Remove the security bezel \(optional\)](#)" on page 31).
2. Power down the server (on page 30).
3. Remove all power:
 - a. Disconnect each power cord from the power source.
 - b. Disconnect each power cord from the server.
4. Do one of the following:
 - o For tower models, place the server on a flat, level surface with the access panel facing up.
 - o For rack models, extend the server from the rack (on page 34).

5. Remove the access panel (on page 32).
6. Locate the fan to be removed ("Hot-plug fans" on page 28).
7. Remove a fan.

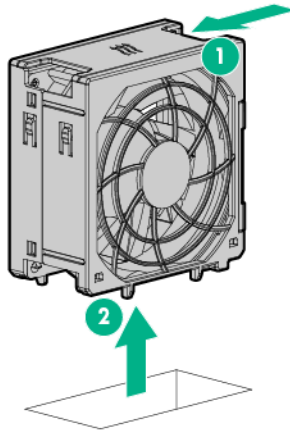

CAUTION: Do not operate the server for long periods with the access panel open or removed. Operating the server in this manner results in improper airflow and improper cooling that can lead to thermal damage.



IMPORTANT: For optimum cooling, install fans in all primary fan locations. For more information, refer to the fan locations table ("Hot-plug fans" on page 28).

Remove the fan cage



IMPORTANT: When installing or replacing server components, one or more fans might need to be removed. To prevent an orderly or immediate server shutdown, Hewlett Packard Enterprise highly recommends powering down the server during these procedures. To determine if powering down is required, see the specific procedure.



IMPORTANT: For optimum cooling, install fans in all primary fan locations. For more information, refer to the fan locations table ("Hot-plug fans" on page 28).

To remove the component:

1. Do one of the following:
 - o For tower models, open and remove the tower bezel ("Remove the tower bezel" on page 31).
 - o For rack models, if installed, remove the security bezel ("Remove the security bezel (optional)" on page 31).
2. Power down the server (on page 30).
3. Remove all power:
 - a. Disconnect each power cord from the power source.
 - b. Disconnect each power cord from the server.
4. Do one of the following:
 - o For tower models, place the server on a flat, level surface with the access panel facing up.

- o For rack models, extend the server from the rack (on page 34).
5. Remove the access panel (on page 32).
 6. Remove the air baffle (on page 34).
 7. Remove the fan cage.

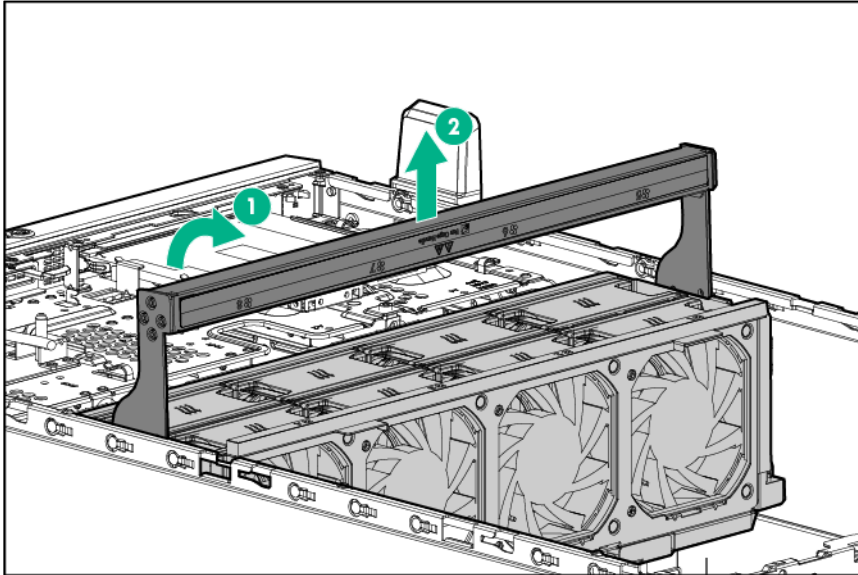

Install the fan cage

1. Install the fan cage.

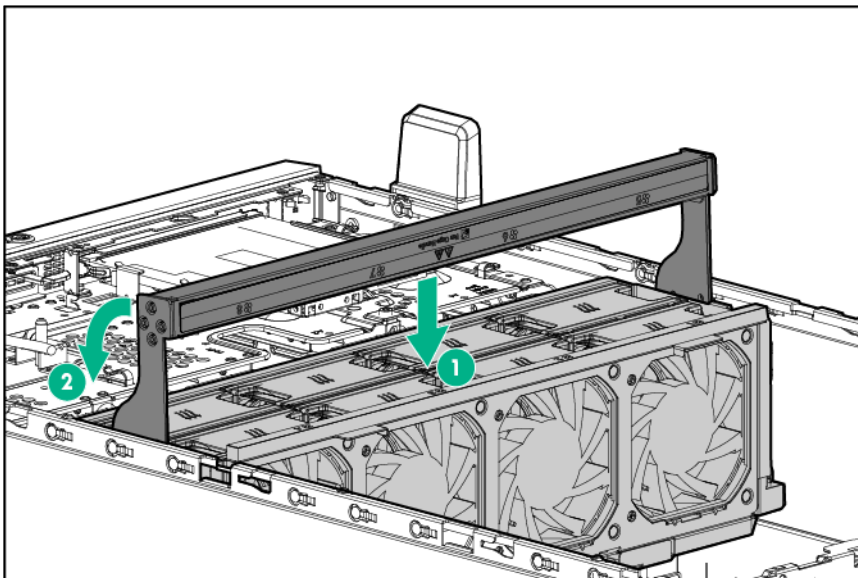

2. Install the access panel (on page 33).
3. Do one of the following:
 - o If the server is in a tower configuration, return the server to an upright position.
 - o If the server is in a rack configuration, slide the server into the rack.
4. Connect each power cord to the server.
5. Connect each power cord to the power source.
6. Power up the server ("[Powering up the server](#)" on page 30).

7. Do one of the following:
 - o For tower models, install the tower bezel (on page 31).
 - o For rack models, install the security bezel ("[Security bezel option](#)" on page 50).

Remove the optical drive

The server supports both DVD-ROM and DVD-RW drives.

1. Do one of the following:
 - o For tower models, open and remove the tower bezel ("[Remove the tower bezel](#)" on page 31).
 - o For rack models, if installed, remove the security bezel ("[Remove the security bezel \(optional\)](#)" on page 31).
2. Power down the server (on page 30).
3. Remove all power:
 - a. Disconnect each power cord from the power source.
 - b. Disconnect each power cord from the server.
4. Do one of the following:
 - o For tower models, place the server on a flat, level surface with the access panel facing up.
 - o For rack models, extend the server from the rack (on page 34).
5. Remove the access panel (on page 32).
6. Remove the air baffle (on page 34).
7. Remove the optical drive:
 - a. Disconnect and remove the optical drive cable.
 - b. Remove the screw and lift the carrier.
 - c. Remove the optical drive from the drive bay.

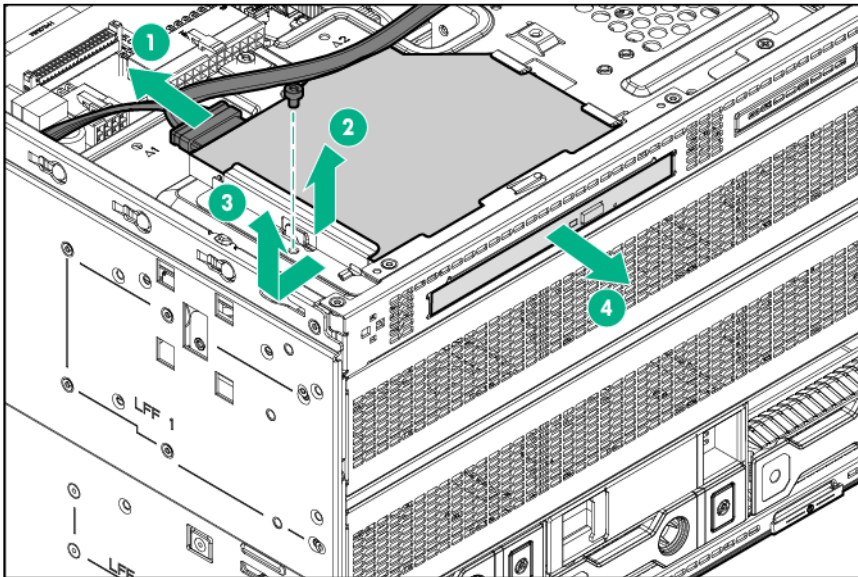

Remove a drive cage blank

1. Do one of the following:
 - o For tower models, open and remove the tower bezel (on page 31).
 - o For rack models, remove the security bezel ("[Remove the security bezel \(optional\)](#)" on page 31).

2. Remove the component drive cage blank:

⚠ WARNING: To reduce the risk of personal injury from an electrical hazard, do not remove more than one drive cage at a time.

- SFF model

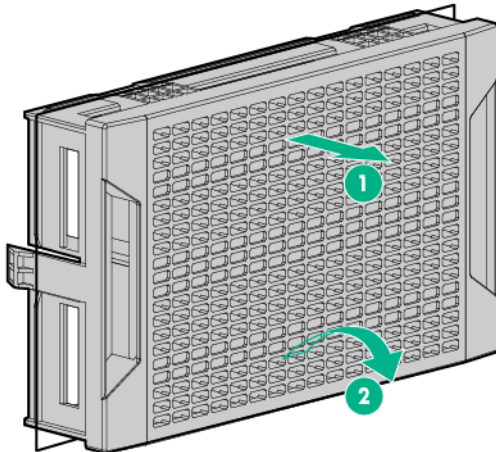

- LFF model

— To remove the drive cage blank from outside the server, use a flathead screwdriver to remove the blank from the box.

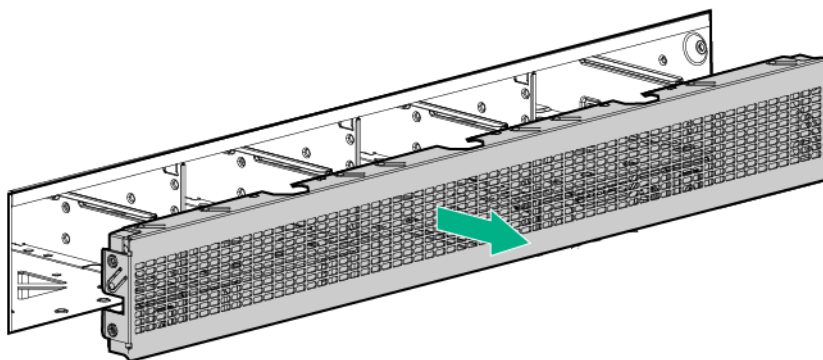

- To remove the drive cage blank from inside the server, push out the drive blank from inside.

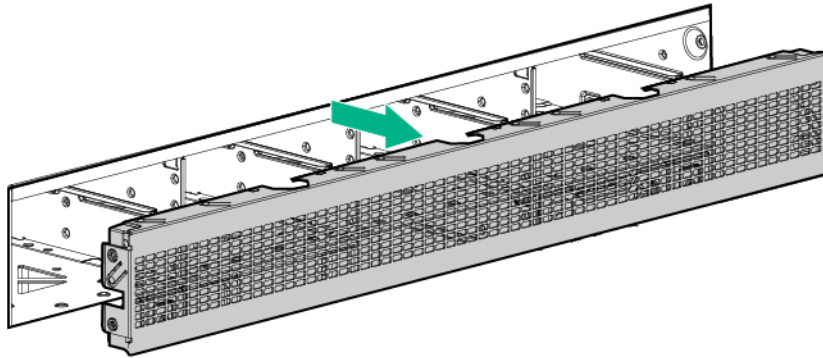

Using the Systems Insight Display

The HPE Systems Insight Display (SID) is only available as an option for rack configurations.

1. Remove the security bezel ("[Remove the security bezel \(optional\)](#)" on page 31), if installed.
2. Press and release the SID panel.

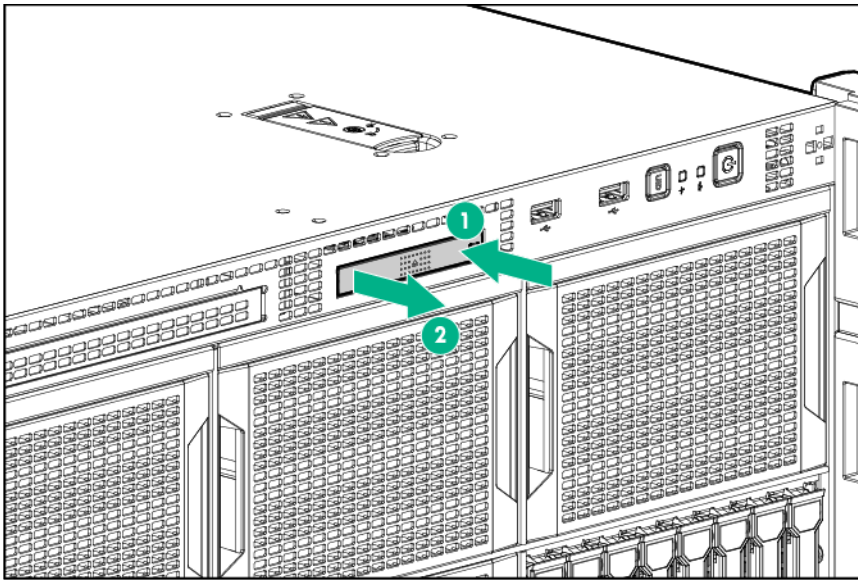

3. After the display fully ejects, rotate the display to view the LEDs.

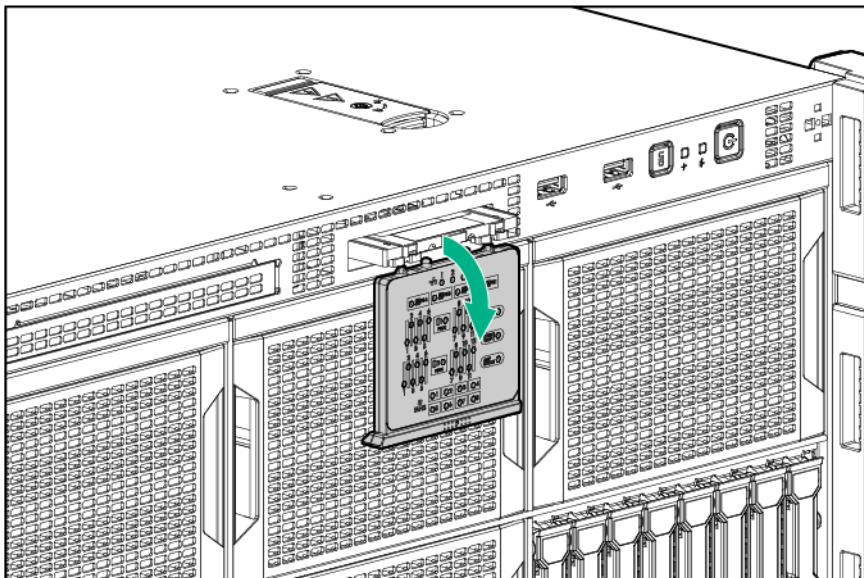

For descriptions of the Systems Insight Display LEDs, see "Systems Insight Display LEDs (on page 13)."

Setup

Optional services

Delivered by experienced, certified engineers, HPE support services help you keep your servers up and running with support packages tailored specifically for HPE ProLiant systems. HPE support services let you integrate both hardware and software support into a single package. A number of service level options are available to meet your business and IT needs.

HPE support services offer upgraded service levels to expand the standard product warranty with easy-to-buy, easy-to-use support packages that will help you make the most of your server investments. Some of the HPE support services for hardware, software or both are:

- Foundation Care – Keep systems running.
 - 6-Hour Call-to-Repair
 - 4-Hour 24x7
 - Next Business Day
- Proactive Care – Help prevent service incidents and get you to technical experts when there is one.
 - 6-Hour Call-to-Repair
 - 4-Hour 24x7
 - Next Business Day
- Startup and implementation services for both hardware and software
- HPE Education Services – Help train your IT staff.

For more information on HPE support services, see the Hewlett Packard Enterprise website (<http://www.hpe.com/services>).

Optimum environment

When installing the server, select a location that meets the environmental standards described in this section.

Space and airflow requirements

Tower server

In a tower configuration, leave at least a 7.6-cm (3-in) clearance space at the front and back of the server for proper ventilation.

Rack server

To allow for servicing and adequate airflow, observe the following space and airflow requirements when deciding where to install a rack:

- Leave a minimum clearance of 85.09 cm (33.5 in) in front of the rack.
- Leave a minimum clearance of 76.2 cm (30 in) behind the rack.
- Leave a minimum clearance of 121.9 cm (48 in) from the back of the rack to the back of another rack or row of racks.

Hewlett Packard Enterprise servers draw in cool air through the front door and expel warm air through the rear door. Therefore, the front and rear rack doors must be adequately ventilated to allow ambient room air to enter the cabinet, and the rear door must be adequately ventilated to allow the warm air to escape from the cabinet.

 **CAUTION:** To prevent improper cooling and damage to the equipment, do not block the ventilation openings.

When vertical space in the rack is not filled by a server or rack component, the gaps between the components cause changes in airflow through the rack and across the servers. Cover all gaps with blanking panels to maintain proper airflow.

 **CAUTION:** Always use blanking panels to fill empty vertical spaces in the rack. This arrangement ensures proper airflow. Using a rack without blanking panels results in improper cooling that can lead to thermal damage.

The 9000 and 10000 Series Racks provide proper server cooling from flow-through perforations in the front and rear doors that provide 64 percent open area for ventilation.

 **CAUTION:** When using a Compaq branded 7000 series rack, install the high airflow rack door insert (PN 327281-B21 for 42U rack, PN 157847-B21 for 22U rack) to provide proper front-to-back airflow and cooling.

 **CAUTION:** If a third-party rack is used, observe the following additional requirements to ensure adequate airflow and to prevent damage to the equipment:

- Front and rear doors—If the 42U rack includes closing front and rear doors, you must allow 5,350 sq cm (830 sq in) of holes evenly distributed from top to bottom to permit adequate airflow (equivalent to the required 64 percent open area for ventilation).
- Side—The clearance between the installed rack component and the side panels of the rack must be a minimum of 7 cm (2.75 in).

Temperature requirements

To ensure continued safe and reliable equipment operation, install or position the system in a well-ventilated, climate-controlled environment.

The maximum recommended ambient operating temperature (TMRA) for most server products is 35°C (95°F). The temperature in the room where the rack is located must not exceed 35°C (95°F).

For information on ambient operating temperature support above 35°C, see the Hewlett Packard Enterprise website (<http://www.hpe.com/servers/ASHRAE>).

 **CAUTION:** To reduce the risk of damage to the equipment when installing third-party options:

- Do not permit optional equipment to impede airflow around the server or to increase the internal rack temperature beyond the maximum allowable limits.
- Do not exceed the manufacturer's TMRA.

Power requirements

Installation of this equipment must comply with local and regional electrical regulations governing the installation of information technology equipment by licensed electricians. This equipment is designed to operate in installations covered by NFPA 70, 1999 Edition (National Electric Code) and NFPA-75, 1992 (code for Protection of Electronic Computer/Data Processing Equipment). For electrical power ratings on options, refer to the product rating label or the user documentation supplied with that option.

 **WARNING:** To reduce the risk of personal injury, fire, or damage to the equipment, do not overload the AC supply branch circuit that provides power to the rack. Consult the electrical authority having jurisdiction over wiring and installation requirements of your facility.



CAUTION: Protect the server from power fluctuations and temporary interruptions with a regulating uninterruptible power supply. This device protects the hardware from damage caused by power surges and voltage spikes and keeps the system in operation during a power failure.

When installing more than one server, you might need to use additional power distribution devices to safely provide power to all devices. Observe the following guidelines:

- Balance the server power load between available AC supply branch circuits.
- Do not allow the overall system AC current load to exceed 80% of the branch circuit AC current rating.
- Do not use common power outlet strips for this equipment.
- Provide a separate electrical circuit for the server.

For more information on the hot-plug power supply and calculators to determine server power consumption in various system configurations, see the Hewlett Packard Enterprise Power Advisor website (<http://www.hpe.com/info/poweradvisor/online>).

Electrical grounding requirements

The server must be grounded properly for proper operation and safety. In the United States, you must install the equipment in accordance with NFPA 70, 1999 Edition (National Electric Code), Article 250, as well as any local and regional building codes. In Canada, you must install the equipment in accordance with Canadian Standards Association, CSA C22.1, Canadian Electrical Code. In all other countries, you must install the equipment in accordance with any regional or national electrical wiring codes, such as the International Electrotechnical Commission (IEC) Code 364, parts 1 through 7. Furthermore, you must be sure that all power distribution devices used in the installation, such as branch wiring and receptacles, are listed or certified grounding-type devices.

Because of the high ground-leakage currents associated with multiple servers connected to the same power source, Hewlett Packard Enterprise recommends the use of a PDU that is either permanently wired to the building's branch circuit or includes a nondetachable cord that is wired to an industrial-style plug. NEMA locking-style plugs or those complying with IEC 60309 are considered suitable for this purpose. Using common power outlet strips for the server is not recommended.

Connecting a DC power cable to a DC power source



WARNING: To reduce the risk of electric shock or energy hazards:

- This equipment must be installed by trained service personnel, as defined by the NEC and IEC 60950-1, Second Edition, the standard for Safety of Information Technology Equipment.
 - Connect the equipment to a reliably grounded Secondary circuit source. A Secondary circuit has no direct connection to a Primary circuit and derives its power from a transformer, converter, or equivalent isolation device.
 - The branch circuit overcurrent protection must be rated 27 A.
-



WARNING: When installing a DC power supply, the ground wire must be connected before the positive or negative leads.



WARNING: Remove power from the power supply before performing any installation steps or maintenance on the power supply.



CAUTION: The server equipment connects the earthed conductor of the DC supply circuit to the earthing conductor at the equipment. For more information, see the documentation that ships with the power supply.



CAUTION: If the DC connection exists between the earthed conductor of the DC supply circuit and the earthing conductor at the server equipment, the following conditions must be met:

- This equipment must be connected directly to the DC supply system earthing electrode conductor or to a bonding jumper from an earthing terminal bar or bus to which the DC supply system earthing electrode conductor is connected.
 - This equipment should be located in the same immediate area (such as adjacent cabinets) as any other equipment that has a connection between the earthed conductor of the same DC supply circuit and the earthing conductor, and also the point of earthing of the DC system. The DC system should be earthed elsewhere.
 - The DC supply source is to be located within the same premises as the equipment.
 - Switching or disconnecting devices should not be in the earthed circuit conductor between the DC source and the point of connection of the earthing electrode conductor.
-

To connect a DC power cable to a DC power source:

1. Cut the DC power cord ends no shorter than 150 cm (59.06 in).
2. If the power source requires ring tongues, use a crimping tool to install the ring tongues on the power cord wires.



IMPORTANT: The ring terminals must be UL approved and accommodate 12 gauge wires.



IMPORTANT: The minimum nominal thread diameter of a pillar or stud type terminal must be 3.5 mm (0.138 in); the diameter of a screw type terminal must be 4.0 mm (0.157 in).

3. Stack each same-colored pair of wires and then attach them to the same power source. The power cord consists of three wires (black, red, and green).

For more information, see the documentation that ships with the power supply.

Server warnings and cautions



WARNING: To reduce the risk of personal injury from hot surfaces, allow the drives and the internal system components to cool before touching them.



WARNING: To reduce the risk of personal injury, electric shock, or damage to the equipment, remove the power cord to remove power from the server. Pressing the Power On/Standby button does not shut off system power completely. Portions of the power supply and some internal circuitry remain active until AC power is removed.



CAUTION: Protect the server from power fluctuations and temporary interruptions with a regulating uninterruptible power supply. This device protects the hardware from damage caused by power surges and voltage spikes and keeps the system in operation during a power failure.



CAUTION: Do not operate the server for long periods with the access panel open or removed. Operating the server in this manner results in improper airflow and improper cooling that can lead to thermal damage.

Identifying the contents of the server shipping carton

Unpack the server shipping carton and locate the materials and documentation necessary for installing the server.

The contents of the server shipping carton include:

- Server
- Power cord
- Tower feet
- Hardware documentation and software products

In addition to the supplied items, you might need:

- Hardware options
- Operating system or application software
- Torx T-15, Philips #2, and flathead screwdriver

Installing hardware options

Install any hardware options before initializing the server. For options installation information, refer to the option documentation. For server-specific information, refer to "Hardware options installation (on page 50)."

Setting up a tower server

Follow the steps in this section to set up a tower model server. To install the server into a rack, see the rack installation section.

1. Lay the server on the side, and then install the feet.

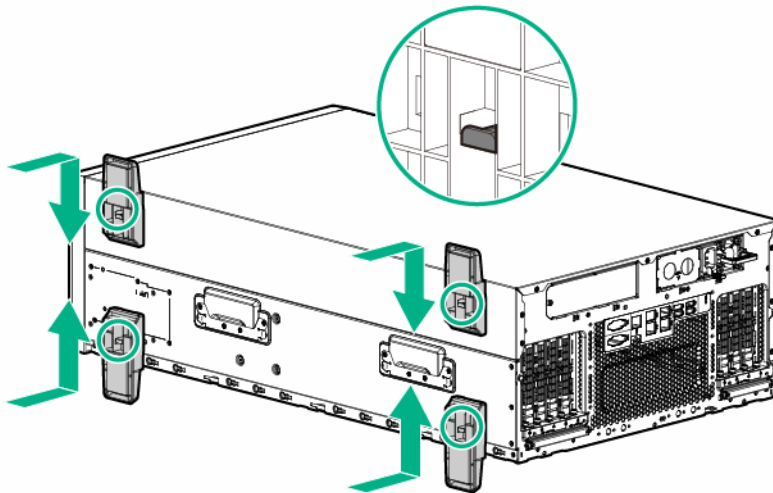

2. Return the server to an upright position.
3. Connect peripheral devices to the server ("[Rear panel components](#)" on page 11).



WARNING: To reduce the risk of electric shock, fire, or damage to the equipment, do not plug telephone or telecommunications connectors into RJ-45 connectors.

4. Connect the power cord to the rear of the server.
5. Connect the power cord to the AC power source.



WARNING: To reduce the risk of electric shock or damage to the equipment:

- Do not disable the power cord grounding plug. The grounding plug is an important safety feature.
 - Plug the power cord into a grounded (earthed) electrical outlet that is easily accessible at all times.
 - Unplug the power cord from the power supply to disconnect power to the equipment.
 - Do not route the power cord where it can be walked on or pinched by items placed against it. Pay particular attention to the plug, electrical outlet, and the point where the cord extends from the server.
-

Installing the server into a rack



WARNING: To reduce the risk of personal injury or damage to the equipment, be sure that:

- The leveling jacks are extended to the floor.
 - The full weight of the rack rests on the leveling jacks.
 - The stabilizing feet are attached to the rack if it is a single-rack installation.
 - The racks are coupled together in multiple-rack installations.
 - Only one component is extended at a time. A rack may become unstable if more than one component is extended for any reason.
-

1. Install the server and cable management arm into the rack. For more information see the installation instructions that ship with the Quick Deploy Rail System.
2. Connect peripheral devices to the server. For information on identifying connectors, see "Rear panel components (on page 11)."
3. Connect the power cord to the server.
4. Secure the cables to the cable management arm.



IMPORTANT: When using cable management arm components, be sure to leave enough slack in each of the cables to prevent damage to the cables when the server is extended from the rack.

5. Connect the power cord to the power source.

Powering on and selecting boot options

This server supports both Legacy BIOS Boot Mode and UEFI Boot Mode. On servers operating in UEFI Boot Mode, the boot controller and boot order are set automatically.

1. Press the Power On/Standby button.
2. Do one of the following:
 - a. To enter the UEFI System Utilities screen and modify the server configuration ROM default settings, press the **F9** key on the ProLiant POST screen. Choose one of the following boot modes:
 - Legacy BIOS
 - UEFI (default)
 - b. If you do not need to modify the server configuration and are ready to install the system software, press the **F10** key to access Intelligent Provisioning.

For more information on automatic configuration, see the UEFI documentation on the Hewlett Packard Enterprise website (<http://www.hpe.com/info/ProLiantUEFI/docs>).

Installing the operating system

This ProLiant server does not ship with provisioning media. Everything needed to manage and install the system software and firmware is preloaded on the server.

To operate properly, the server must have a supported operating system. Attempting to run an unsupported operating system can cause serious and unpredictable results. For the latest information on operating system support, see the Hewlett Packard Enterprise website (<http://www.hpe.com/info/supportos>).

Failure to observe UEFI requirements for ProLiant Gen9 servers can result in errors installing the operating system, failure to recognize boot media, and other boot failures. For more information on these requirements, see the *HPE UEFI Requirements* on the Hewlett Packard Enterprise website (<http://www.hpe.com/info/ProLiantUEFI/docs>).

To install an operating system on the server, use one of the following methods:

- Intelligent Provisioning—For single-server deployment, updating, and provisioning capabilities.
To install an operating system on the server with Intelligent Provisioning (local or remote):
 - a. Connect the Ethernet cable between the network connector on the server and a network jack.
 - b. Press the Power On/Standby button.
 - c. During server POST, press **F10**.
 - d. Complete the initial Preferences and Registration portion of Intelligent Provisioning (on page 152, on page 152).
 - e. At the 1 Start screen, click **Configure and Install**.
 - f. To finish the installation, follow the onscreen prompts. An Internet connection is required to update the firmware and systems software.
- Insight Control server provisioning—For multi-server remote OS deployment, use Insight Control server provisioning for an automated solution. For more information, see the Insight Control documentation on the Hewlett Packard Enterprise website (<http://www.hpe.com/info/insightcontrol/docs>).

For additional system software and firmware updates, download the Service Pack for ProLiant from the Hewlett Packard Enterprise website (<http://www.hpe.com/servers/spp/download>). Software and firmware must be updated before using the server for the first time, unless any installed software or components require an older version.

For more information, see "Keeping the system current (on page 160)."

For more information on using these installation methods, see the Hewlett Packard Enterprise website (<http://www.hpe.com/info/ilo>).

Registering the server

To experience quicker service and more efficient support, register the product at the Hewlett Packard Enterprise Product Registration website (<http://www.hpe.com/info/register>).

Hardware options installation

Product QuickSpecs

For more information about product features, specifications, options, configurations, and compatibility, see the product QuickSpecs on the Hewlett Packard Enterprise website (<http://www.hpe.com/info/qs>).

Introduction

If more than one option is being installed, read the installation instructions for all the hardware options and identify similar steps to streamline the installation process.

WARNING: To reduce the risk of personal injury from hot surfaces, allow the drives and the internal system components to cool before touching them.

CAUTION: To prevent damage to electrical components, properly ground the server before beginning any installation procedure. Improper grounding can cause electrostatic discharge.

Security bezel option

Install the security bezel into the chassis, and then lock the security bezel with the key.

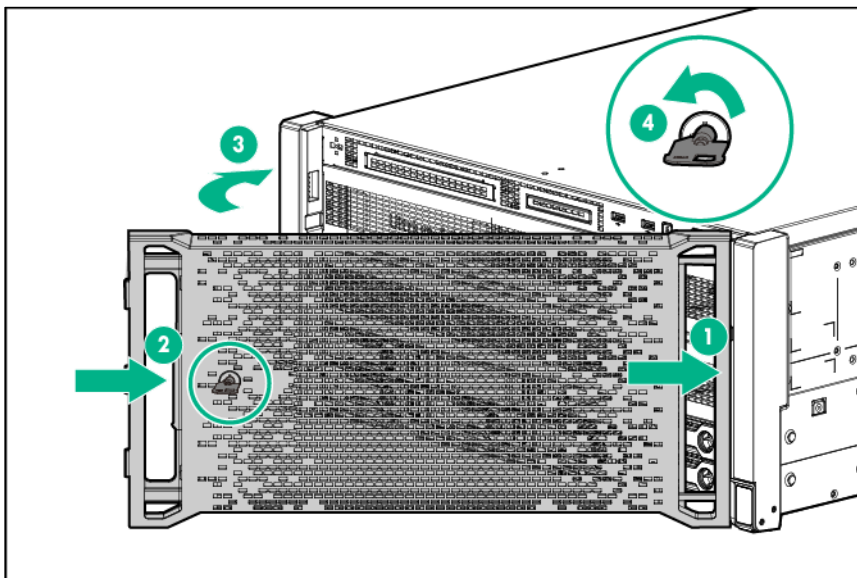

Tower to rack conversion



WARNING: This server is heavy. To reduce the risk of personal injury or damage to the equipment:

- Observe local occupational health and safety requirements and guidelines for manual material handling.
- Get help to lift and stabilize the product during installation or removal, especially when the product is not fastened to the rails. Hewlett Packard Enterprise recommends that a minimum of two people are required for all rack server installations. A third person may be required to help align the server if the server is installed higher than chest level.
- Use caution when installing the server in or removing the server from the rack; it is unstable when not fastened to the rails.



CAUTION: Always plan the rack installation so that the heaviest item is on the bottom of the rack. Install the heaviest item first, and continue to populate the rack from the bottom to the top.

1. Back up all server data, and record configuration information.
2. Close all applications, and then shut down the operating system.
3. Unlock and remove the tower bezel from the chassis, and then remove the standoffs.

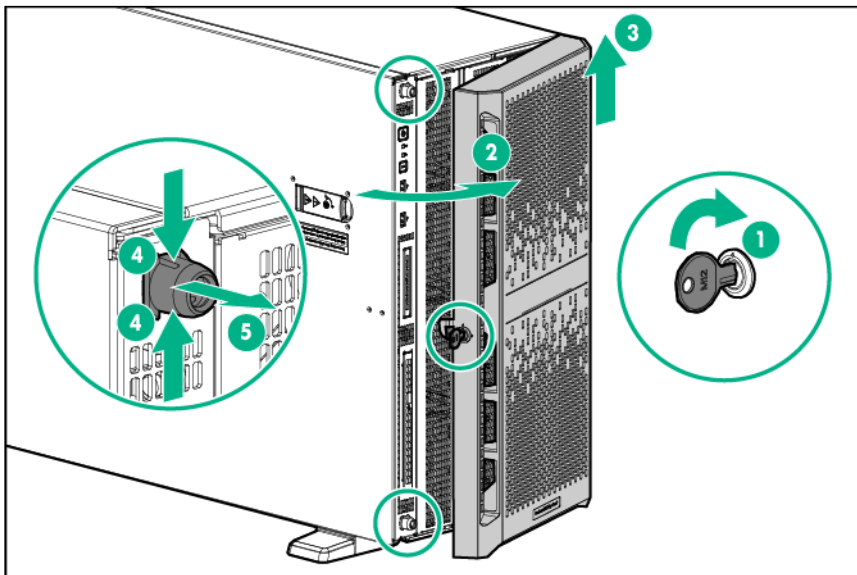

4. Power off the server by pressing the power button on the front of the server.
5. Disconnect all AC power cords from the AC outlets, and then disconnect all AC power cords from the server.
6. Place the server on its side on a flat, level work surface.

7. Remove the server base feet.

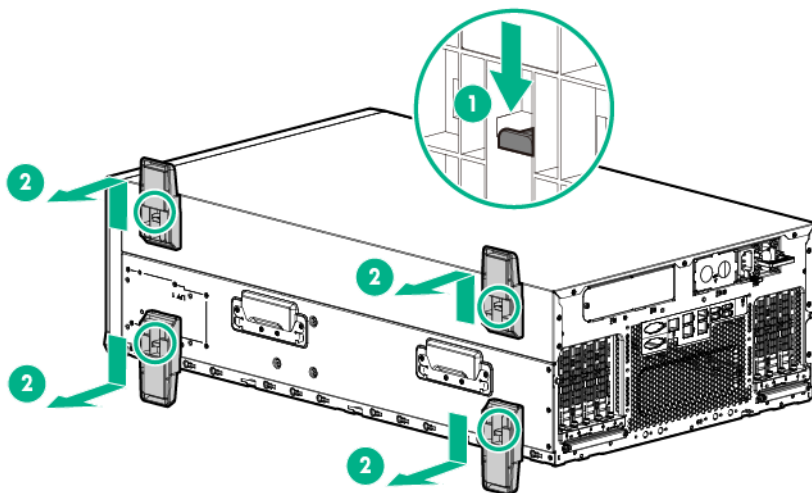

8. Remove all screws securing the base cover to the chassis.
9. Slide the base cover toward the rear of the server, and then remove the base cover.

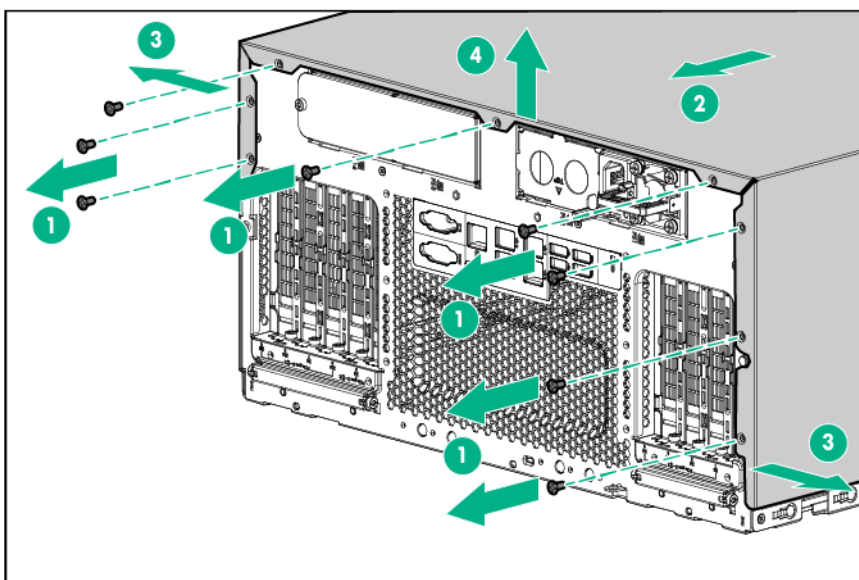

10. Install the server base blank covers over the server base feet holes.

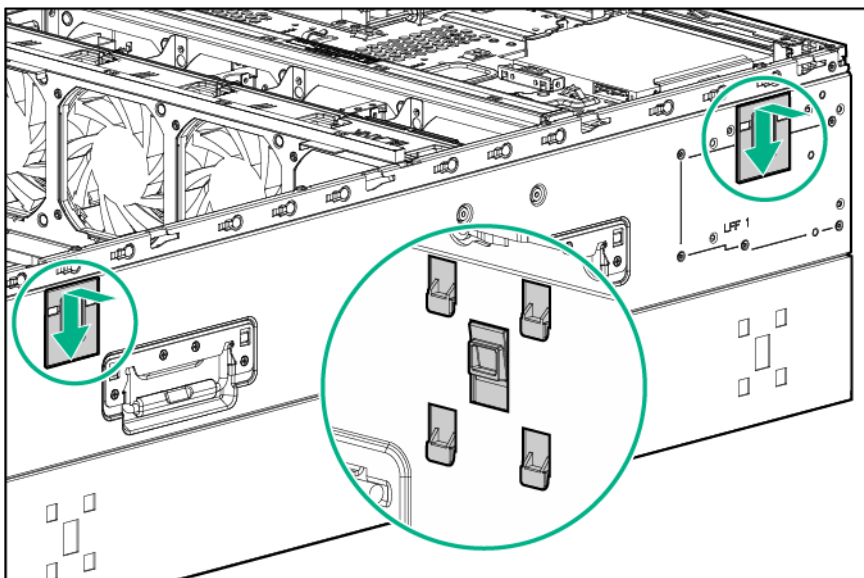

11. Turn the server over, and then remove the access panel (on page 32).
12. Remove the air baffle (on page 34).
13. Remove the fan cage (on page 37).
14. Locate the system maintenance switch on the system board.

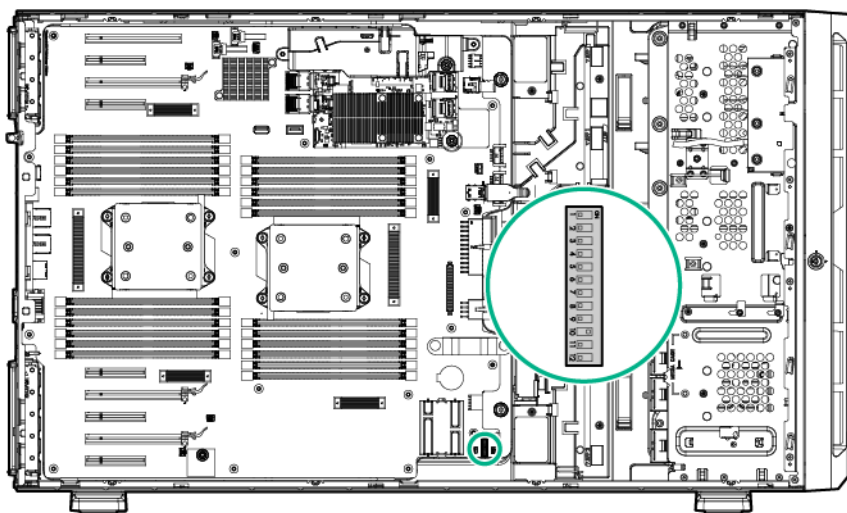

15. Configure position 10 of the system maintenance switch to ON for a rack configuration.



16. Install the left and right rack bezel ears.

- a. Insert and completely tighten the 3 long silver T-15 screws on the upper side of each rack bezel ear.
- b. Insert and completely tighten the 2 short black T-15 screws on the lower side of each rack bezel ear.

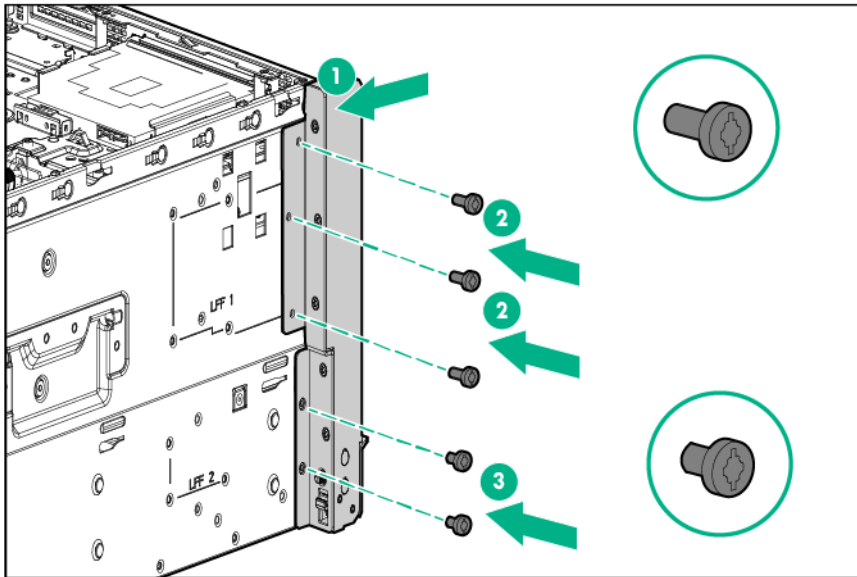

17. Install the front bezel hinge covers.

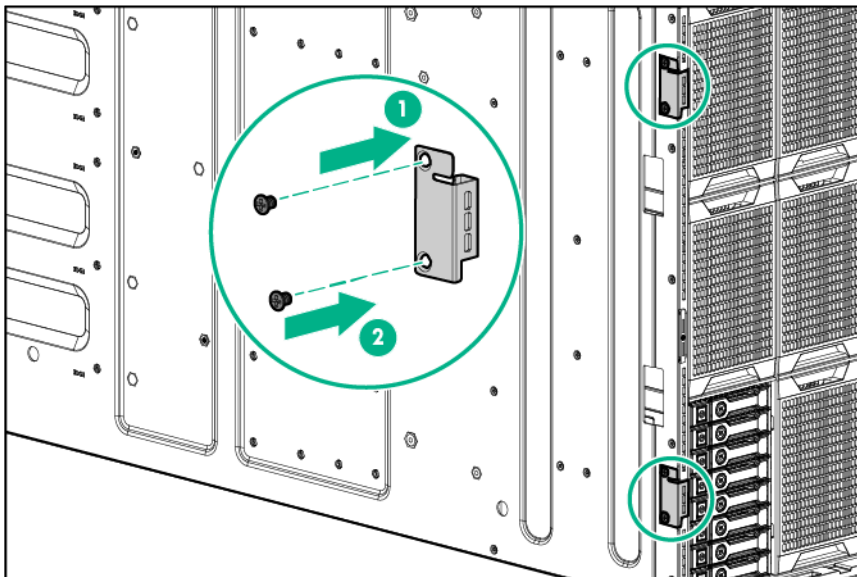

18. Remove the handle hole covers from the chassis, and retain the screws.

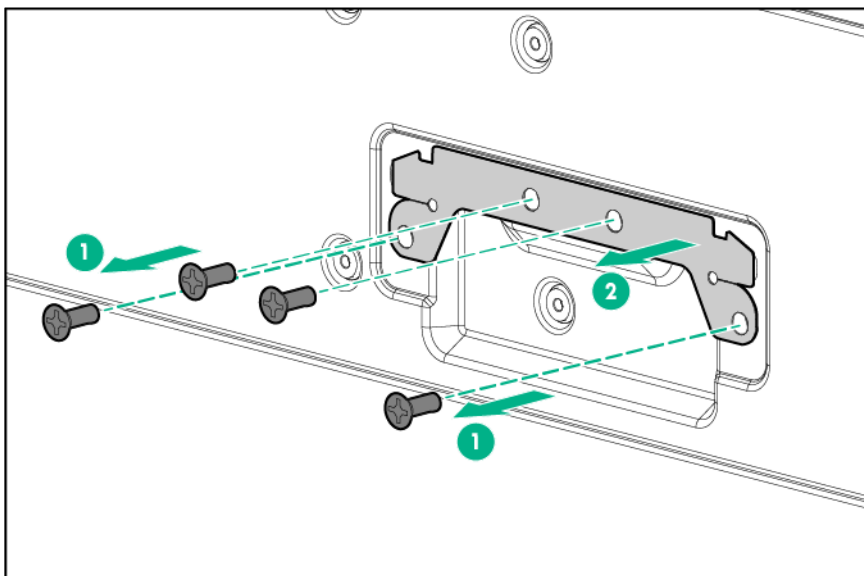

19. Install the rack server handles.

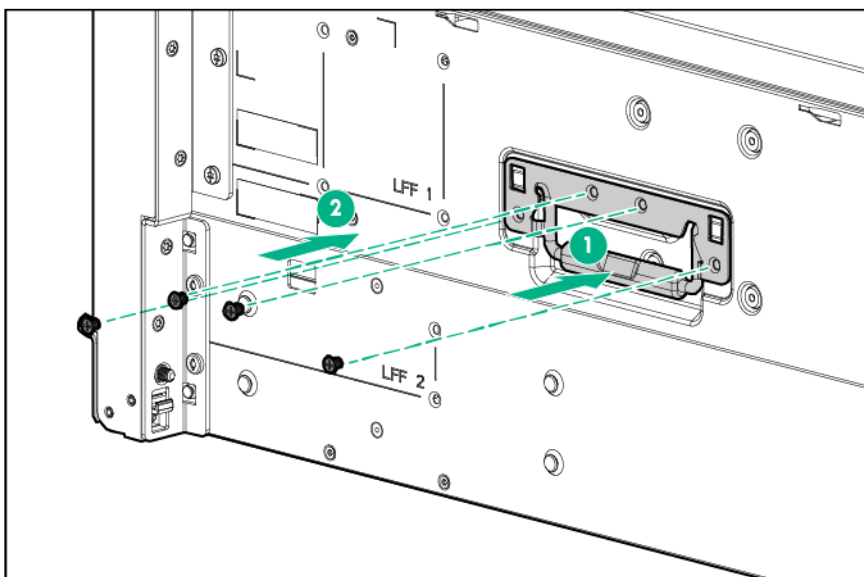

20. Install the fan cage (on page 38).

21. Install the air baffle (on page 35).

22. Install the SID blank.

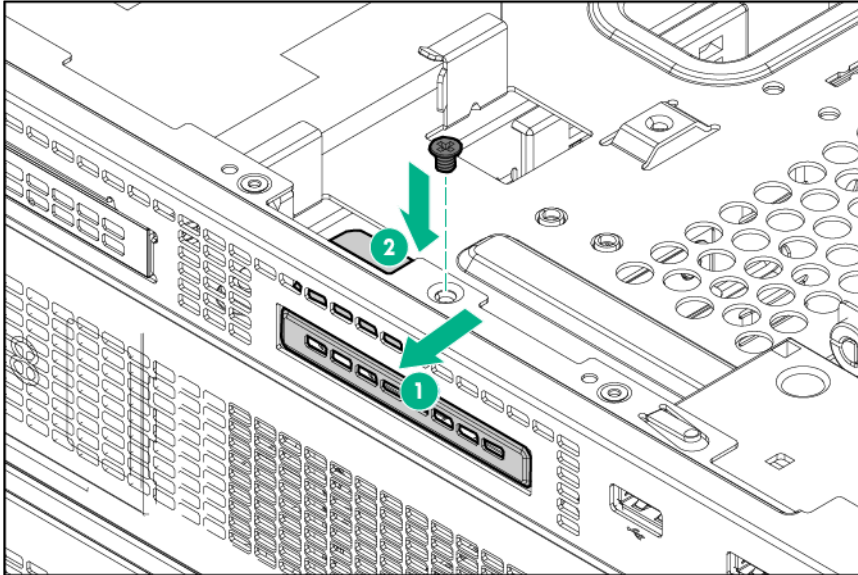

23. Install the access panel (on page 33).
24. Install the server onto the rack rails, and then slide the assembly into the rack.

NOTE: For detailed instructions on installing the server into the rack, see the Quick Deploy Rail System Installation Instructions included with the kit.

25. Connect peripheral devices to the server. For information on identifying connectors, see "Rear panel components (on page 11)."

⚠ WARNING: To reduce the risk of electric shock, fire, or damage to the equipment, do not plug telephone or telecommunications connectors into RJ-45 connectors.

26. Connect the power cord to the rear of the server.
27. Connect the power cord to the power source.

⚠ WARNING: To reduce the risk of electric shock or damage to the equipment:

- Do not disable the power cord grounding plug. The grounding plug is an important safety feature.
- Plug the power cord into a grounded (earthed) electrical outlet that is easily accessible at all times.
- Unplug the power cord from the power supply to disconnect power to the equipment.
- Do not route the power cord where it can be walked on or pinched by items placed against it. Pay particular attention to the plug, electrical outlet, and the point where the cord extends from the server.

Systems Insight Display option

The HPE Systems Insight Display (SID) is only available as an option for rack configurations.

1. If installed, remove the security bezel ("[Remove the security bezel \(optional\)](#)" on page 31).
2. Power down the server (on page 30).
3. Remove all power:
 - a. Disconnect each power cord from the power source.
 - b. Disconnect each power cord from the server.

4. Extend the server from the rack (on page 34).
5. Remove the access panel (on page 32).
6. Remove the air baffle (on page 34).
7. Remove the fan cage (on page 37).



CAUTION: When routing cables, always be sure that the cables are not in a position where they can be pinched or crimped.

8. Install the SID module into the front panel, and then secure the SID module to the chassis with the screws from the kit.

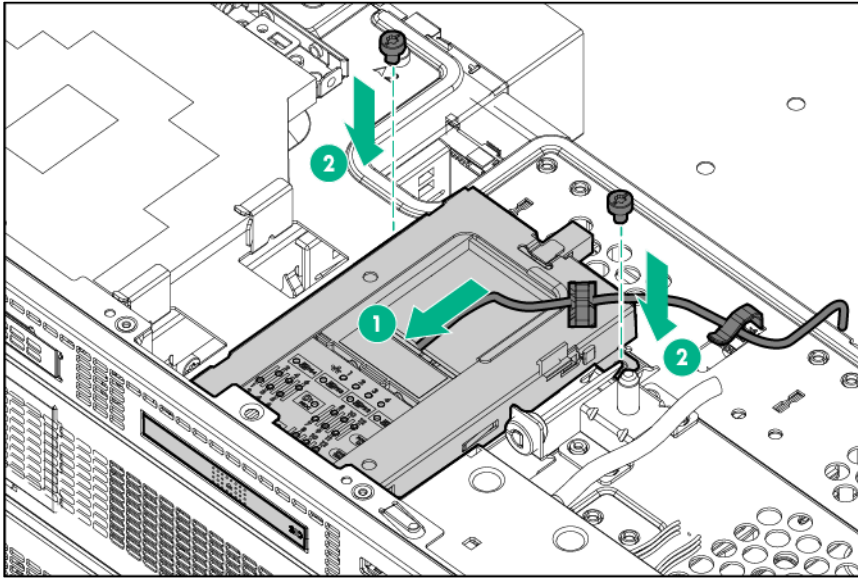

9. Route and connect the SID module cable to the system board.
 - o LFF configuration

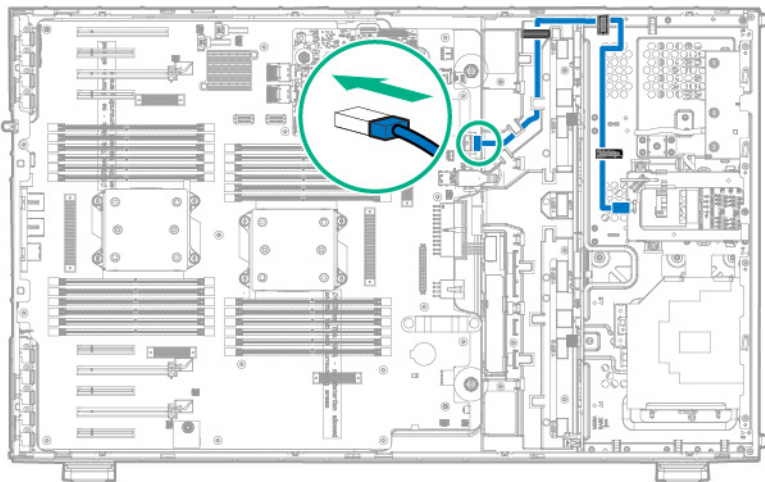

- SFF configuration

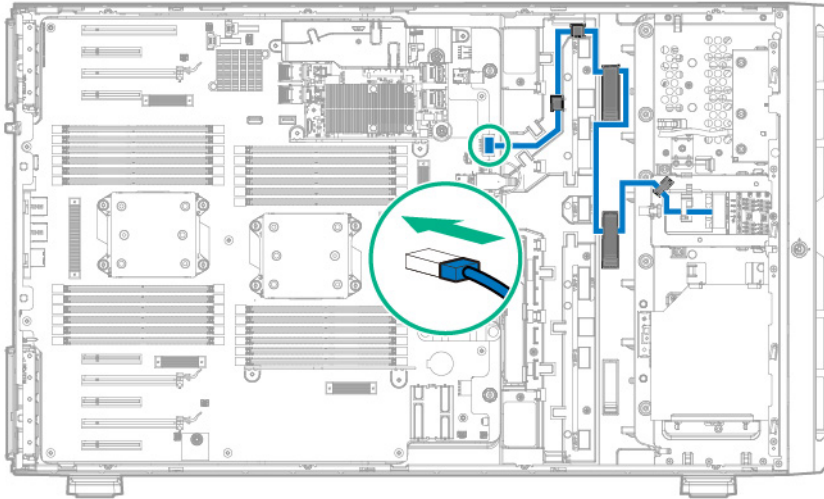

10. Install the fan cage (on page 38).
11. Install the air baffle (on page 35).
12. Install the access panel (on page 33).
13. Slide the server into the rack.
14. Connect each power cord to the server.
15. Connect each power cord to the power source.
16. Power up the server ("Powering up the server" on page 30).
17. Install the security bezel ("Security bezel option" on page 50).

Drive options

For a list of drive configurations supported in this server, see "Device numbering (on page 19)."

The embedded Dynamic Smart Array B140i Controller only supports SATA devices. For SAS drive installation, install a Host Bus Adapter or a Smart Array Controller board option ("Storage controller options" on page 62).

For more information about product features, specifications, options, configurations, and compatibility, see the product QuickSpecs on the Hewlett Packard Enterprise website (<http://www.hpe.com/info/qs>).

Drive installation guidelines

When adding drives to the server, observe the following general guidelines:

- The system automatically sets all device numbers.
- Populate drive bays, based on the drive numbering sequence. Start from the drive bay with the lowest device number ("Device numbering" on page 19).
- All drives grouped into the same drive array must meet the following criteria:
 - They must be either all SAS or all SATA.
 - They must be either all hard drives or all solid-state drives.
 - Drives should be the same capacity to provide the greatest storage space efficiency when drives are grouped together into the same drive array.

Removing a drive blank

1. Do one of the following:
 - o For tower models, open and remove the tower bezel (on page 31).
 - o For rack models, if installed, remove the security bezel ("[Remove the security bezel \(optional\)](#)" on page 31).
2. Remove the drive blank.

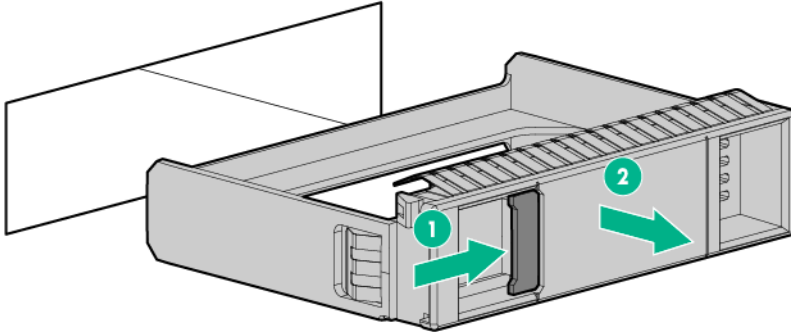

Installing a hot-plug SAS or SATA drive



WARNING: To reduce the risk of injury from electric shock, do not install more than one drive carrier at a time.

The server can support up to 24 drives in an LFF configuration and up to 48 drives in an SFF configuration.

To install the component:

1. Do one of the following:
 - o For tower models, open and remove the tower bezel (on page 31).
 - o For rack models, if installed, remove the security bezel ("[Remove the security bezel \(optional\)](#)" on page 31).
2. Remove the drive blank ("[Removing a drive blank](#)" on page 59).
3. Prepare the drive.

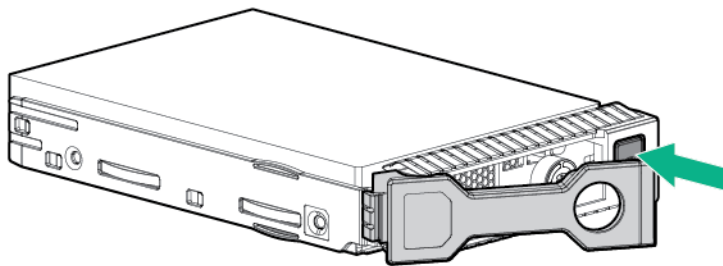

4. Install the drive.

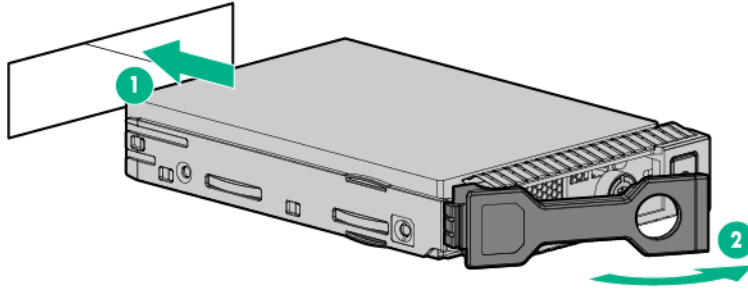

5. Determine the status of the drive from the drive LED definitions ("Hot-plug drive LED definitions" on page 26).
6. Do one of the following:
 - o For tower models, install the tower bezel (on page 31).
 - o For rack models, if removed, install the security bezel ("Security bezel option" on page 50).

To configure arrays, see the *HPE Smart Storage Administrator User Guide* on the Hewlett Packard Enterprise website (<http://www.hpe.com/info/smartstorage/docs>).

Removing a hot-plug SAS or SATA drive

CAUTION: For proper cooling, do not operate the server without the access panel, baffles, expansion slot covers, or blanks installed. If the server supports hot-plug components, minimize the amount of time the access panel is open.

1. Do one of the following:
 - o For tower models, open and remove the tower bezel (on page 31).
 - o For rack models, if installed, remove the security bezel ("Remove the security bezel (optional)" on page 31).
2. Determine the status of the drive from the hot-plug SAS drive LED combinations ("Hot-plug drive LED definitions" on page 26).
3. Back up all server data.
4. Remove the drive.

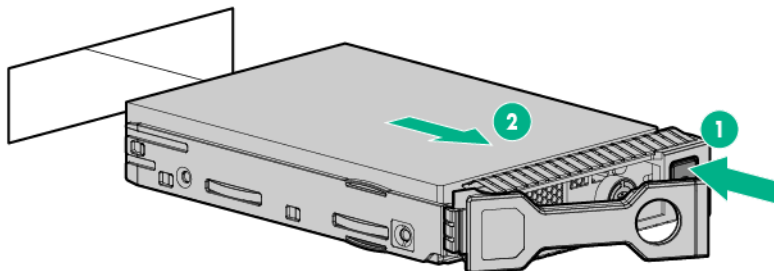

Installing NVMe drives

NVMe drives are supported on this server when the Express bay kit is installed. For installation instructions, see "Installing the HPE NVMe Express bay (on page 83)." For more information on which bays support NVMe drives, see "Device numbering (on page 19)."

To install the drives:

CAUTION: To prevent improper cooling and thermal damage, do not operate the server or the enclosure unless all drive and device bays are populated with either a component or a blank.

1. Back up all server data.
2. Do one of the following:
 - o For tower models, open and remove the tower bezel ("[Remove the tower bezel](#)" on page 31).
 - o For rack models, if installed, remove the security bezel ("[Remove the security bezel \(optional\)](#)" on page 31).
3. Remove the drive blank, if installed.

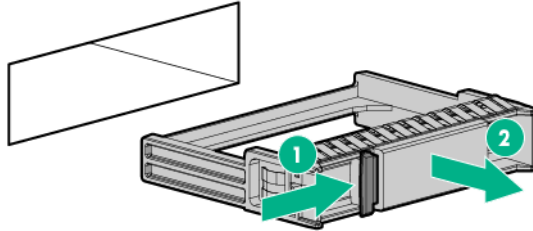

4. Press the Do Not Remove button to open the release handle, see "[NVMe SSD components and LEDs](#)" on page 27."

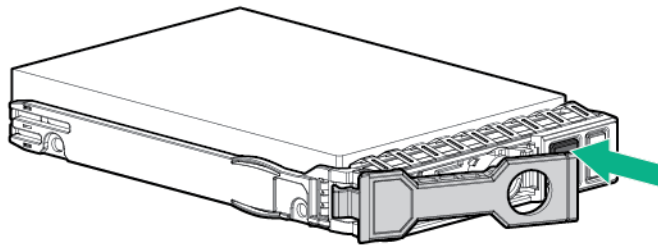

5. Install the drives.

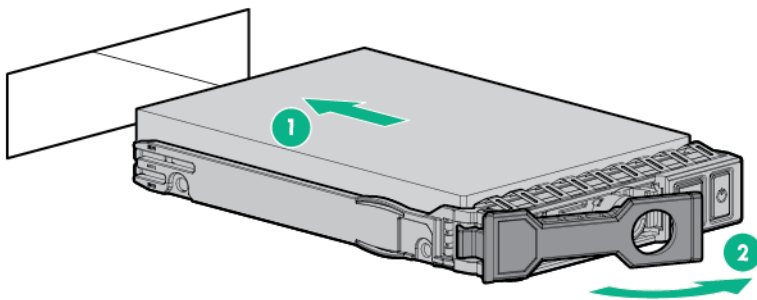

6. Install an SFF drive blank in any unused drive bays.

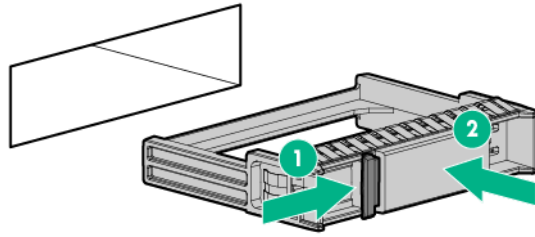

7. Do one of the following:
 - o For tower models, install the tower bezel (on page 31).
 - o For rack models, install the security bezel ("Security bezel option" on page 50).

Storage controller options

The server includes an embedded Dynamic Smart Array B140i Controller. For more information about the controller and its features, see the *HPE Dynamic Smart Array B140i RAID Controller User Guide* on the Hewlett Packard Enterprise website (<http://www.hpe.com/info/smartstorage/docs>).



IMPORTANT: The Dynamic Smart Array B140i Controller supports UEFI Boot Mode only. It does not support Legacy BIOS Boot Mode.

Upgrade options also exist for an integrated array controller, SAS Expander, and NVMe SSD Express bay. For a list of supported options, see the product QuickSpecs on the Hewlett Packard Enterprise website (<http://www.hpe.com/info/qs>).

To configure arrays, see the *HPE Smart Storage Administrator User Guide* on the Hewlett Packard Enterprise website (<http://www.hpe.com/info/smartstorage/docs>).

Installing a Flexible Smart Array Controller option



CAUTION: Hewlett Packard Enterprise recommends performing a complete backup of all server data before performing a controller or adapter installation or removal.

An HPE Smart Array P440ar Controller or HPE H240ar Smart Host Bus Adapter provides support for up to 8 internal SAS/SATA drives without using a PCIe slot.

An HPE Flexible Smart Array Controller Mini-SAS cable option is required to install an HPE Flexible Smart Array Controller option. Before installing the controller, observe the following requirements:

- To ensure cables are connected correctly, observe the labels on the cable and component connectors.
- Check that you have installed the latest firmware for the controllers, HBAs, and the expander card. To download the latest firmware, see the Hewlett Packard Enterprise website (<http://www.hpe.com/support/hpesc>).

To install the component:

1. Back up all server data.
2. Do one of the following:
 - o For tower models, open and remove the tower bezel ("Remove the tower bezel" on page 31).

- o For rack models, if installed, remove the security bezel ("[Remove the security bezel \(optional\)](#)" on page [31](#)).
- 3. Power down the server (on page [30](#)).
- 4. Remove all power:
 - a. Disconnect each power cord from the power source.
 - b. Disconnect each power cord from the server.
- 5. Do one of the following:
 - o For tower models, place the server on a flat, level surface with the access panel facing up.
 - o For rack models, extend the server from the rack (on page [34](#)).
- 6. Remove the access panel (on page [32](#)).
- 7. Remove the air baffle (on page [34](#)).
- 8. Remove the fan cage (on page [37](#)).
- 9. Disconnect the Mini-SAS cables from the embedded Smart Array controller.
- 10. Remove the cable management clip:
 - a. Release any cable secured by the clip.
 - b. Remove the screws on the clip.
 - c. Lift and remove the clip.

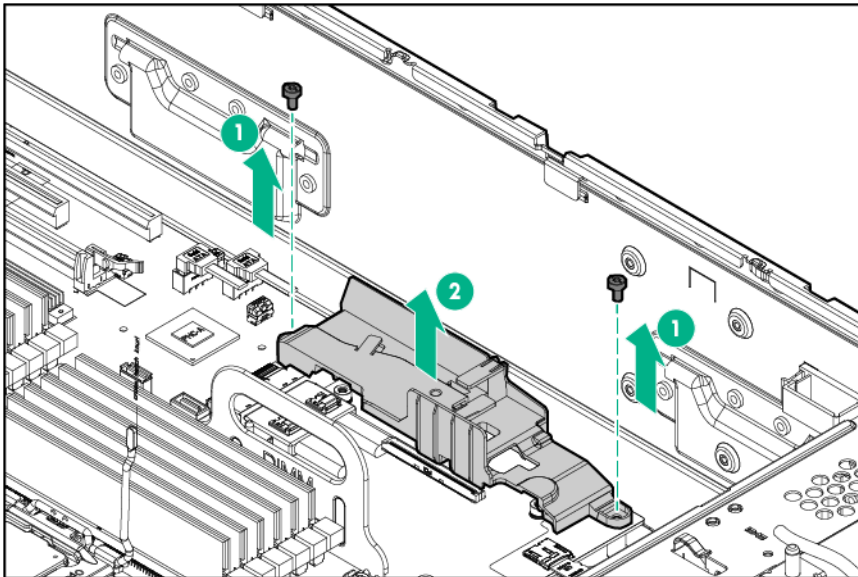

11. Install the Flexible Smart Array Controller.

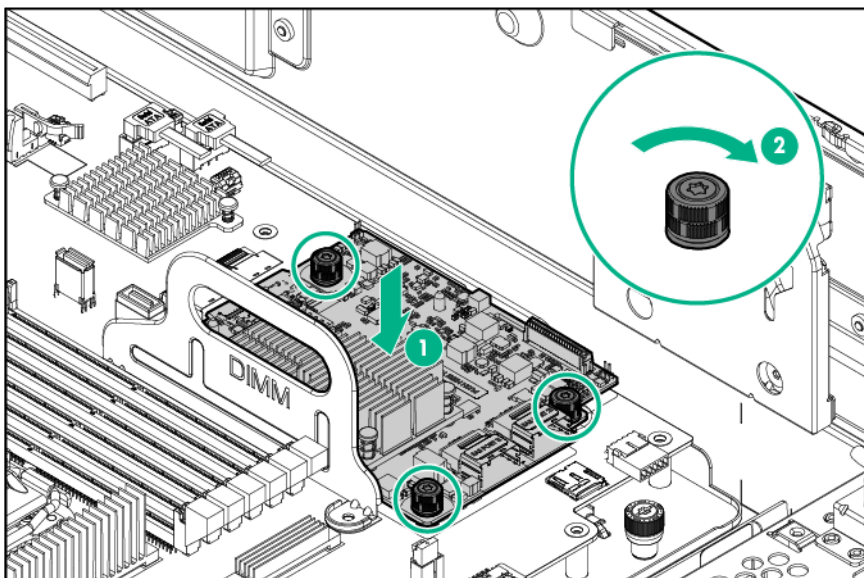

12. Connect the Mini-SAS cables from the drive backplane to the Flexible Smart Array Controller.
o SFF configuration

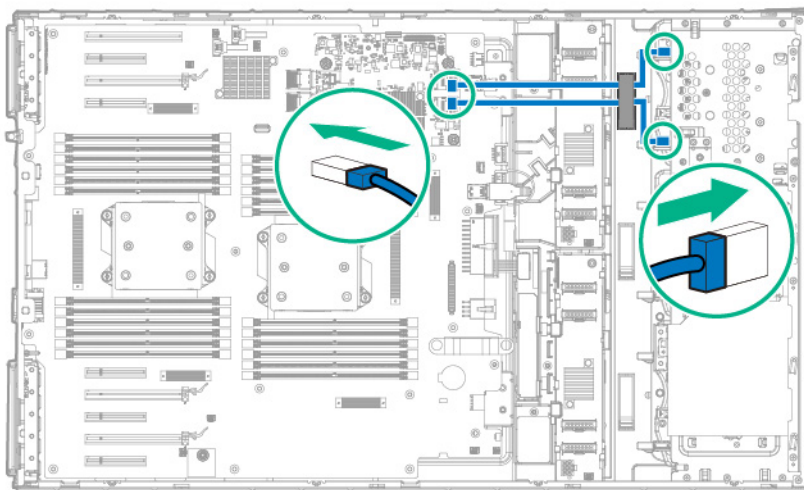

- o LFF configuration

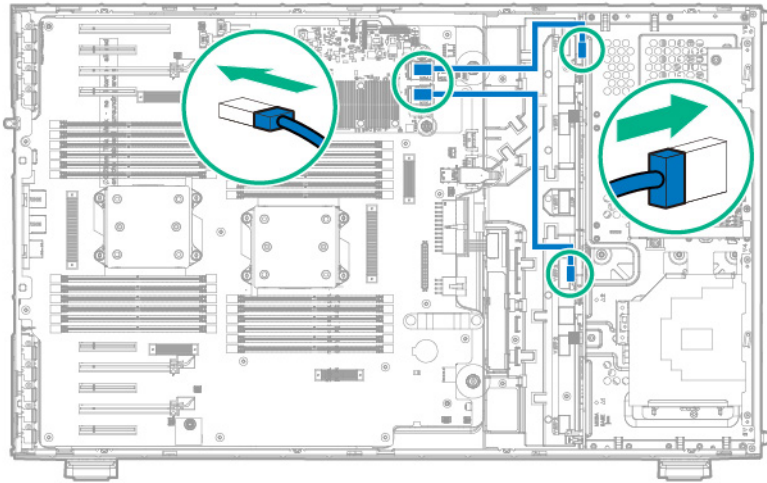

13. Install the cable management clip and secure the cable previously removed from the clip.
14. Install the fan cage (on page 38).
15. Install the air baffle (on page 35).
16. Install the access panel (on page 33).
17. Do one of the following:
 - o If the server is in a tower configuration, return the server to an upright position.
 - o If the server is in a rack configuration, slide the server into the rack.
18. Connect each power cord to the server.
19. Connect each power cord to the power source.
20. Power up the server ("Powering up the server" on page 30).
21. Do one of the following:
 - o For tower models, install the tower bezel (on page 31).
 - o For rack models, install the security bezel ("Security bezel option" on page 50).

Installing an HPE Host Bus Adapter

NOTE: Smart Array controllers are not supported in PCIe slot 5.

To install the component:

1. Back up all server data.
2. Do one of the following:
 - o For tower models, open and remove the tower bezel ("Remove the tower bezel" on page 31).
 - o For rack models, if installed, remove the security bezel ("Remove the security bezel (optional)" on page 31).
3. Power down the server (on page 30).
4. Remove all power:
 - a. Disconnect each power cord from the power source.
 - b. Disconnect each power cord from the server.

5. Do one of the following:
 - o For tower models, place the server on a flat, level surface with the access panel facing up.
 - o For rack models, extend the server from the rack (on page 34).
6. Remove the access panel (on page 32).
7. Remove the air baffle (on page 34).
8. Remove the fan cage (on page 37).
9. Install the host bus adapter.
 - a. Select an available expansion slot from PCIe slots 1 to 4 or 6 to 9, and then remove the slot cover of the corresponding slot.

If installing the HBA in slots 6-9, a second processor option must be installed first. See "Processor option (on page 90)."
 - b. Install the host bus adapter, verify that the board is firmly seated in the slot.

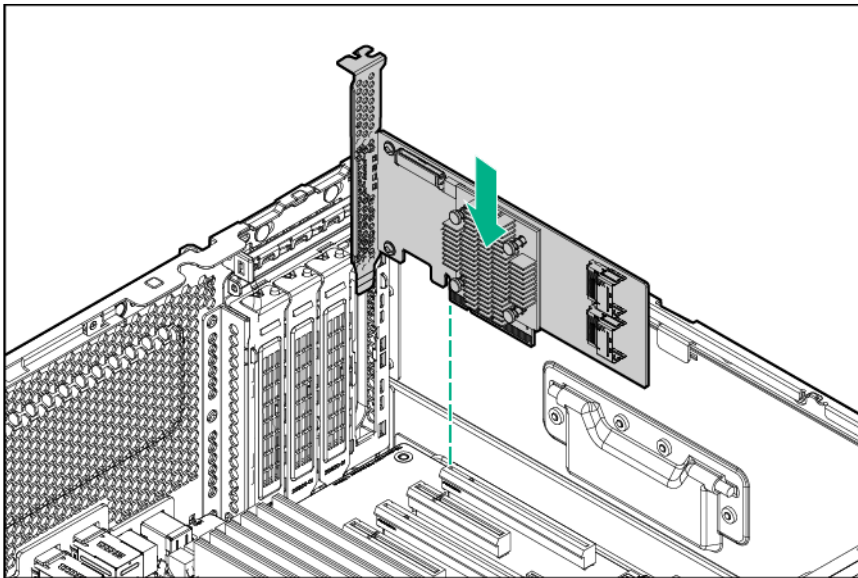

- c. Close the slot retainer or the screw to secure the controller.
10. Connect one end of each Mini-SAS cable to the host bus adapter and the other end of the cable to the drive backplane:
 - o Cable routing if the host bus adapter is installed in PCIe slot 1 to 4

— SFF configuration

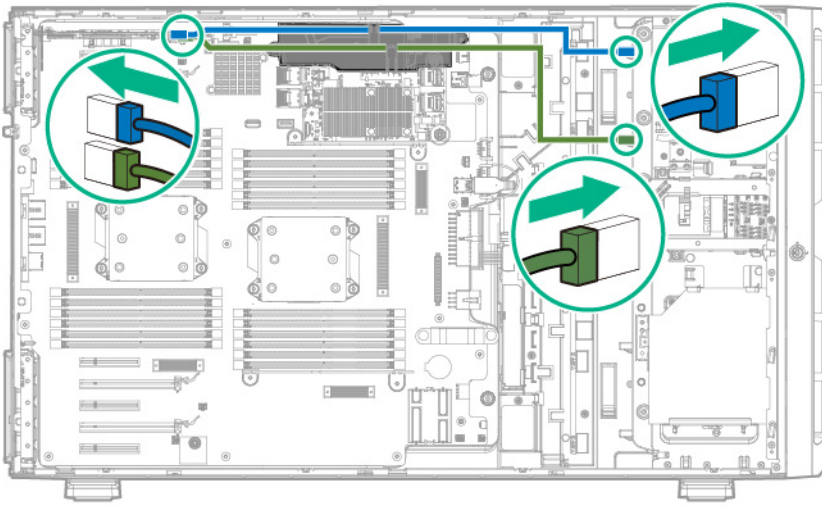

— LFF configuration

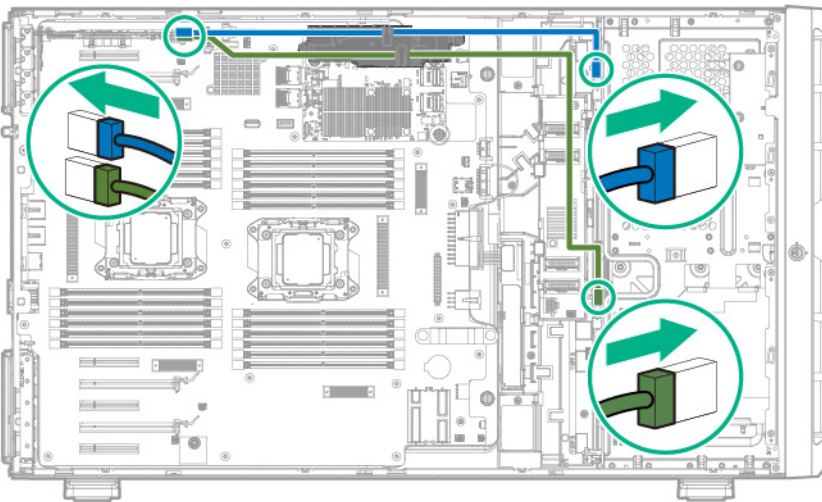

- Cable routing if a second processor is installed and the host bus adapter is installed in PCIe slot 6 to 9

— SFF configuration

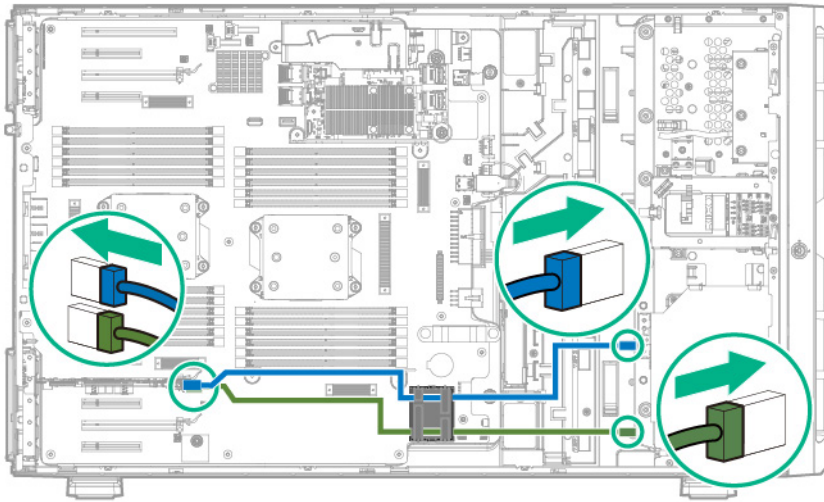

— LFF configuration

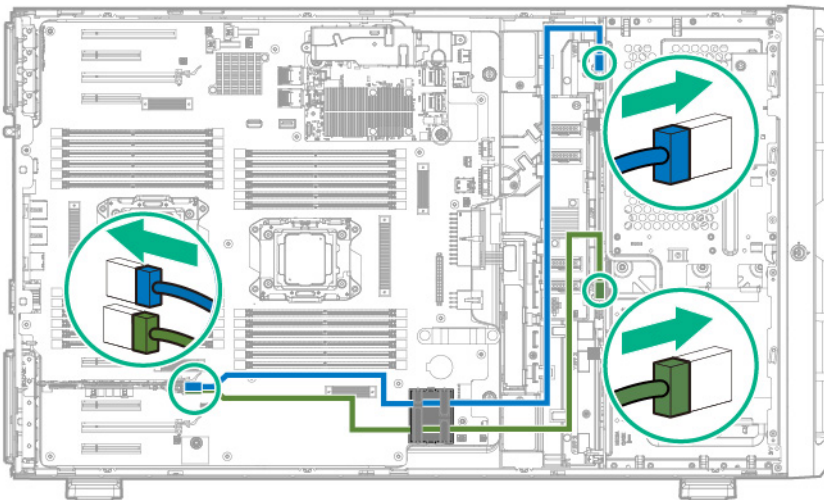

11. Install the fan cage (on page 38).
12. Install the air baffle (on page 35).
13. Install the access panel (on page 33).
14. Do one of the following:
 - If the server is in a tower configuration, return the server to an upright position.
 - If the server is in a rack configuration, slide the server into the rack.
15. Connect each power cord to the server.
16. Connect each power cord to the power source.
17. Power up the server ("Powering up the server" on page 30).
18. Do one of the following:
 - For tower models, install the tower bezel (on page 31).
 - For rack models, install the security bezel ("Security bezel option" on page 50).

Installing a storage controller and FBWC module option

NOTE: Smart Array controllers are not supported in PCIe slot 5.

An HPE Smart Array Controller Mini-SAS cable option is required to install a Smart Array Controller option.

To install the component:

1. Back up all server data.
2. Do one of the following:
 - o For tower models, open and remove the tower bezel ("[Remove the tower bezel](#)" on page 31).
 - o For rack models, if installed, remove the security bezel ("[Remove the security bezel \(optional\)](#)" on page 31).
3. Power down the server (on page 30).
4. Remove all power:
 - a. Disconnect each power cord from the power source.
 - b. Disconnect each power cord from the server.
5. Do one of the following:
 - o For tower models, place the server on a flat, level surface with the access panel facing up.
 - o For rack models, extend the server from the rack (on page 34).
6. Remove the access panel (on page 32).
7. If you intend to use an FBWC module, install the module on the storage controller. Depending on the controller model, the cable connector on the cache module might be facing up or down when the module is installed on the controller board.
 - a. Connect the cache module backup power cable to the module.

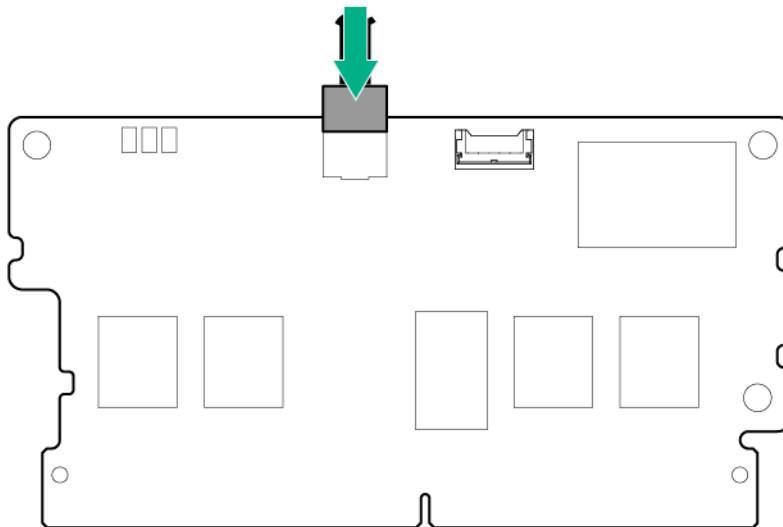

- b. Install the cache module on the storage controller.

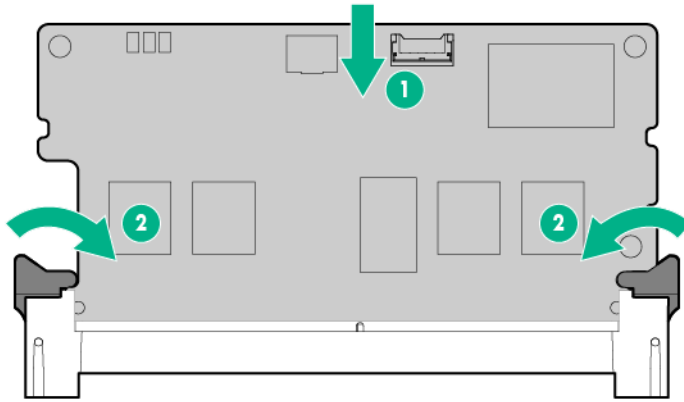

8. Install the Smart Array controller.

- a. Select an available expansion slot from PCIe slots 1 to 4 or 6 to 9, and then remove the slot cover of the corresponding slot.

If installing the HBA in slots 6-9, a second processor option must be installed first. See "Processor option (on page 90)."

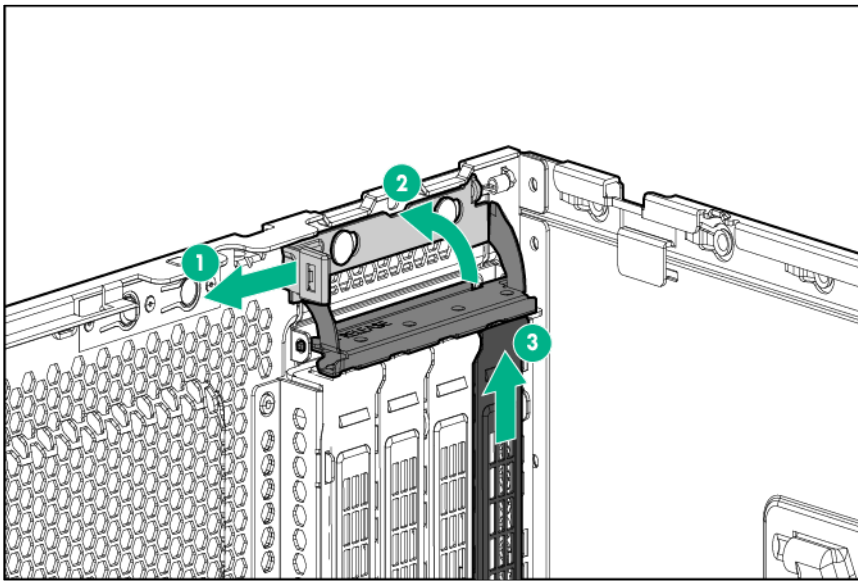

- b. Install the Smart Array controller. Verify that the board is firmly seated in the slot.

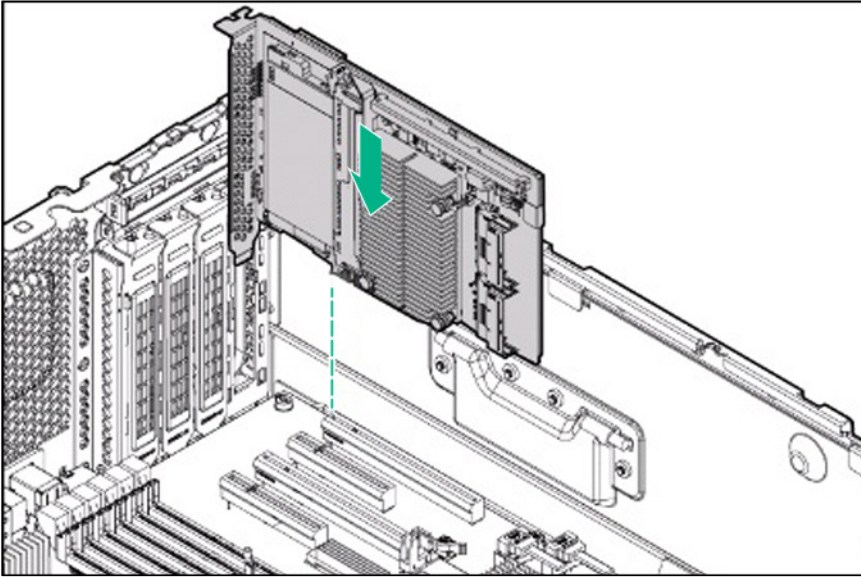

9. Close the slot retainer or tighten the screw to secure the controller.
10. Connect the Mini-SAS Y-cable:
- a. Connect the common end of the Mini-SAS Y-cable to the Smart Array controller.
 - b. Route the two ends of the Mini-SAS Y-cable through the cable management clips, and then connect them to the drive backplane.
 - o Cable routing if the Smart Array controller is installed in PCIe slot 1 to 4
 - SFF configuration

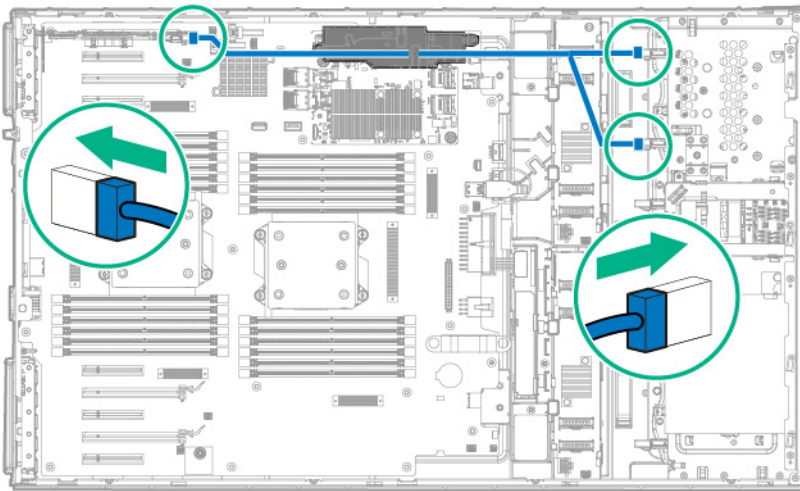

— LFF configuration

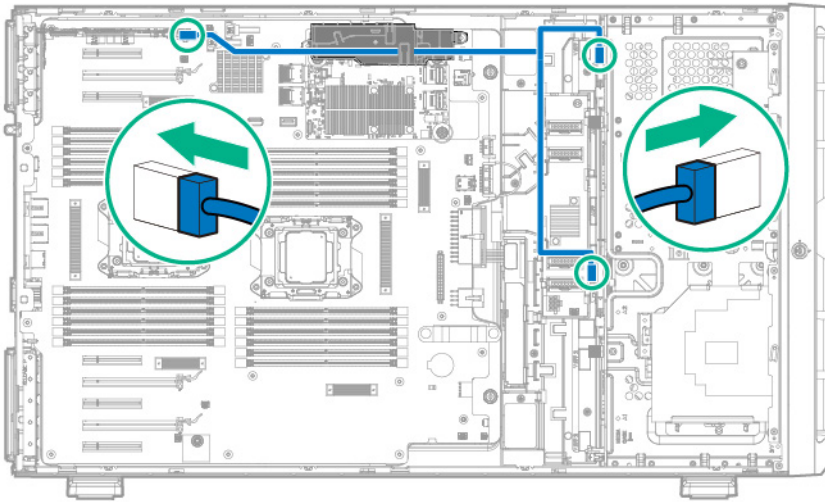

- o Cable routing if a second processor is installed and the Smart Array controller is installed in PCIe slot 6 to 9

— SFF configuration

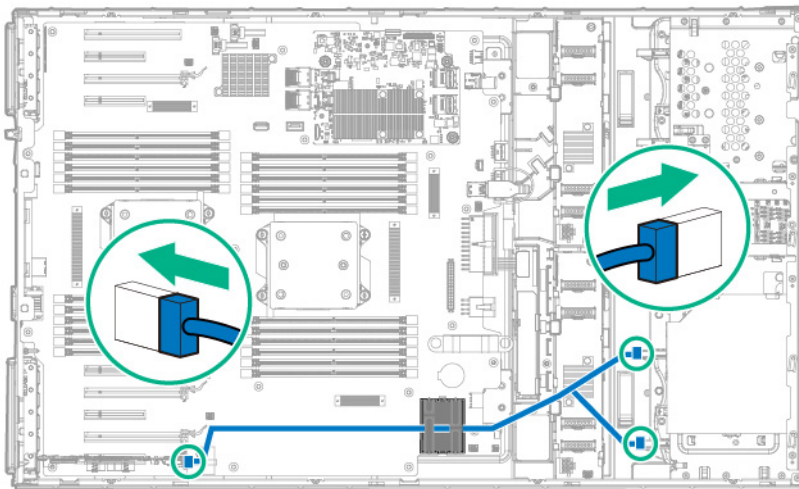

— LFF configuration

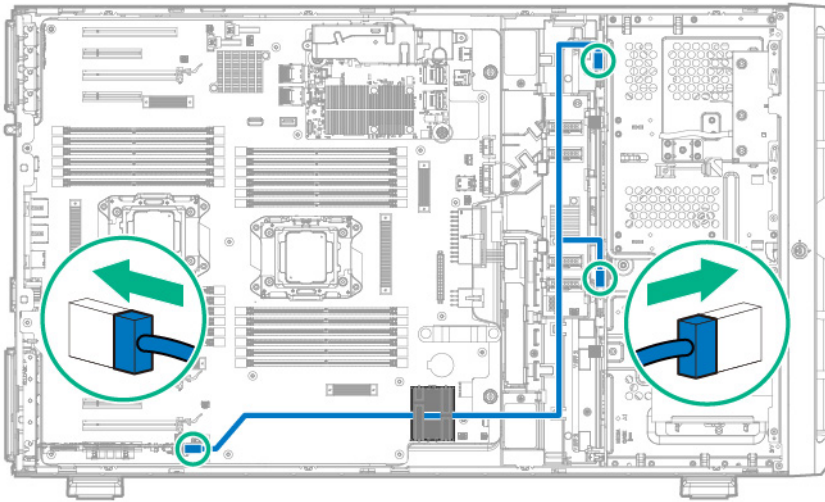

11. If the cache module is installed on the Smart Array controller, connect the cache module backup power cable to the system board.
There are two FBWC module backup power cable connectors available for each group of PCIe connectors.
 - o Backup power cabling when the Smart Array controller is installed in PCIe slot 1 to 4

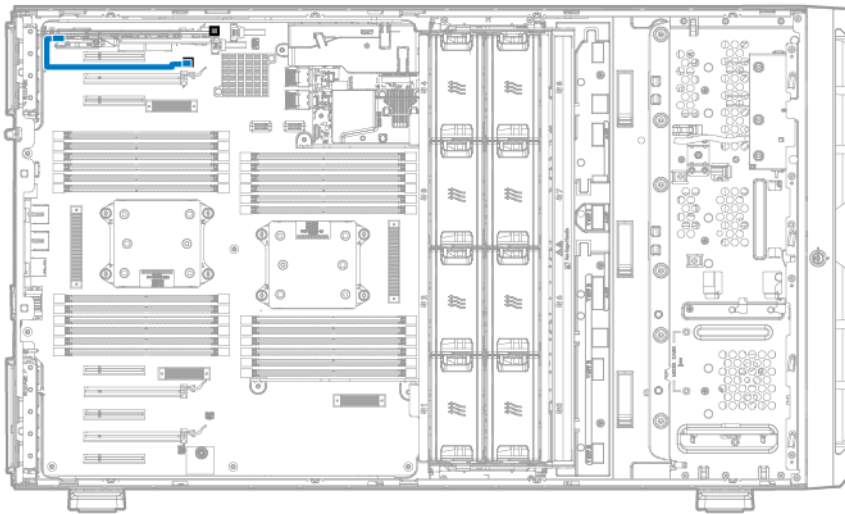

- Backup power cabling when the Smart Array controller is installed in PCIe slot 6 to 9

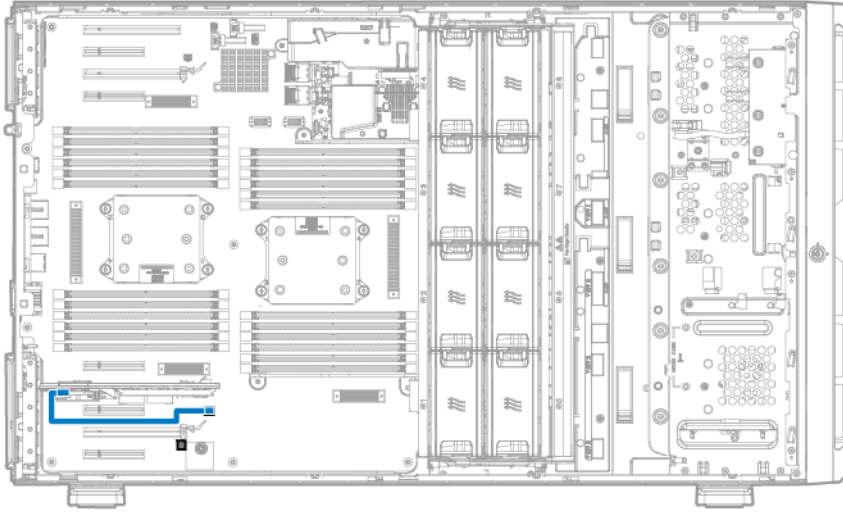

12. If you are planning to install the Smart Storage Battery, install it now ("[Installing an HPE Smart Storage Battery](#)" on page 74).
13. Install the fan cage (on page 38).
14. Install the air baffle (on page 35).
15. Install the access panel (on page 33).
16. Do one of the following:
 - If the server is in a tower configuration, return the server to an upright position.
 - If the server is in a rack configuration, slide the server into the rack.
17. Connect each power cord to the server.
18. Connect each power cord to the power source.
19. Power up the server ("[Powering up the server](#)" on page 30).
20. Do one of the following:
 - For tower models, install the tower bezel (on page 31).
 - For rack models, install the security bezel ("[Security bezel option](#)" on page 50).

For more information on the Smart Array storage controllers, select the relevant user documentation on the Hewlett Packard Enterprise website (<http://www.hpe.com/info/smartstorage/docs>).

To configure arrays, see the *HPE Smart Storage Administrator User Guide* on the Hewlett Packard Enterprise website (<http://www.hpe.com/info/smartstorage/docs>).

Installing an HPE Smart Storage Battery

For more information about product features, specifications, options, configurations, and compatibility, see the product QuickSpecs on the Hewlett Packard Enterprise website (<http://www.hpe.com/info/qs>).

CAUTION: In systems that use external data storage, be sure that the server is the first unit to be powered down and the last to be powered back up. Taking this precaution ensures that the system does not erroneously mark the external drives as failed when the server is powered up.

To install the component:

1. Back up all server data.

2. Do one of the following:
 - o For tower models, open and remove the tower bezel ("Remove the tower bezel" on page 31).
 - o For rack models, if installed, remove the security bezel ("Remove the security bezel (optional)" on page 31).
3. Power down the server (on page 30).
4. Remove all power:
 - a. Disconnect each power cord from the power source.
 - b. Disconnect each power cord from the server.
5. Do one of the following:
 - o For tower models, place the server on a flat, level surface with the access panel facing up.
 - o For rack models, extend the server from the rack (on page 34).
6. Remove the access panel (on page 32).
7. Remove the air baffle (on page 34).
8. Remove the fan cage (on page 37).
9. Install the Smart Storage battery.

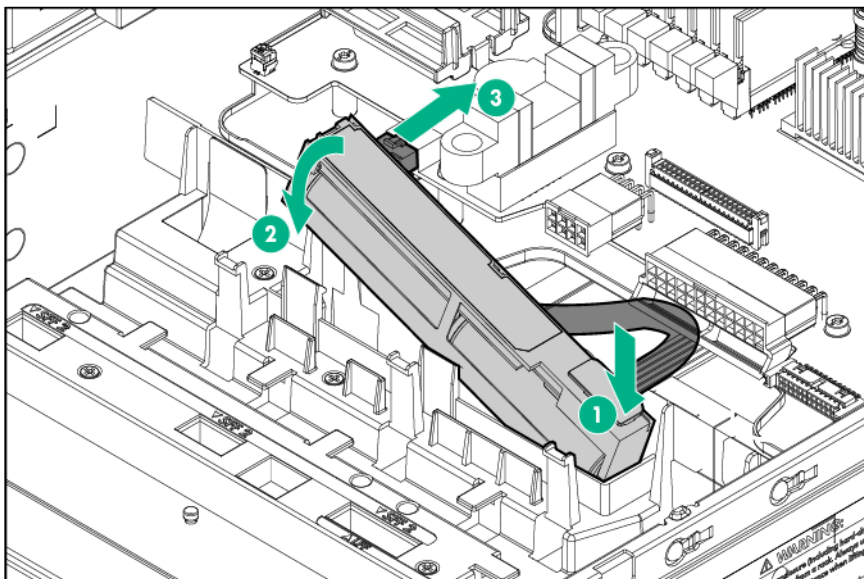

10. Route and connect the cable.

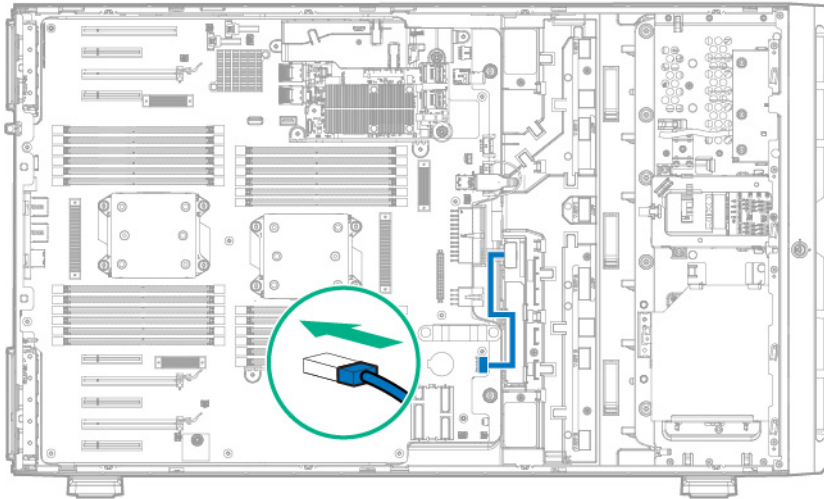

11. Install the fan cage (on page 38).
12. Install the air baffle (on page 35).
13. Install the access panel (on page 33).
14. Do one of the following:
 - If the server is in a tower configuration, return the server to an upright position.
 - If the server is in a rack configuration, slide the server into the rack.
15. Connect each power cord to the server.
16. Connect each power cord to the power source.
17. Power up the server ("Powering up the server" on page 30).
18. Do one of the following:
 - For tower models, install the tower bezel (on page 31).
 - For rack models, install the security bezel ("Security bezel option" on page 50).

Installing a SAS Expander option

The SAS Expander requires an Smart Array or HBA. A SAS Expander cannot be connected to H240ar or P440ar Flexible Smart Array controller cards. The SAS Expander kit includes two cables to connect from the Smart Array or Host Bus Adapter PCIe expander card to the SAS Expander.

Expanders can only be installed in SFF models.

Check that you have installed the latest firmware for the controllers, HBAs, and the expander card. To download the latest firmware, see the Hewlett Packard Enterprise website (<http://www.hpe.com/support/hpesc>).

To install the component:

1. Back up all server data.
2. Do one of the following:
 - For tower models, open and remove the tower bezel ("Remove the tower bezel" on page 31).
 - For rack models, if installed, remove the security bezel ("Remove the security bezel (optional)" on page 31).
3. Power down the server (on page 30).

4. Remove all power:
 - a. Disconnect each power cord from the power source.
 - b. Disconnect each power cord from the server.
5. Do one of the following:
 - o For tower models, place the server on a flat, level surface with the access panel facing up.
 - o For rack models, extend the server from the rack (on page 34).
6. Remove the access panel (on page 32).
7. Remove the air baffle (on page 34).
8. Remove the fan cage (on page 37).
9. Remove the expansion slot retainer cover and the slot blank.

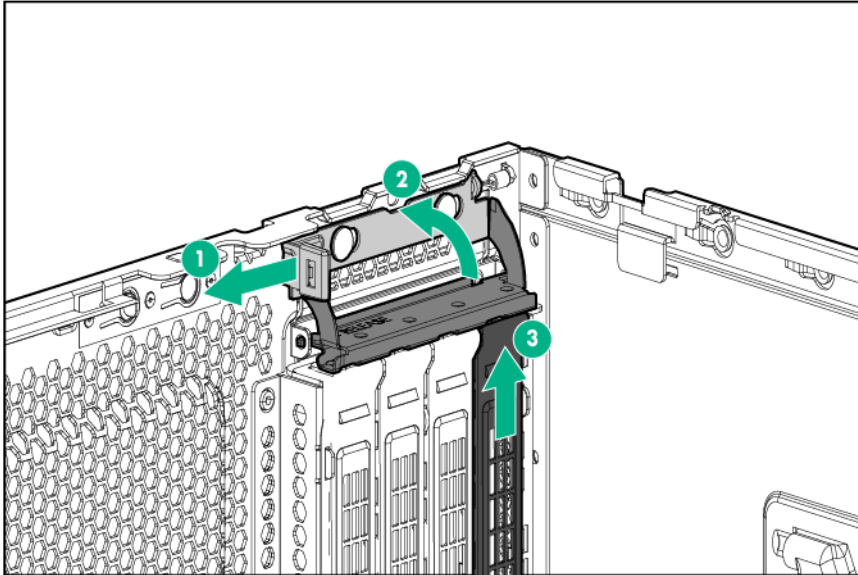

10. Identify the ports on the expander card.



11. Connect the Expander card to the storage controller. Do one of the following:

- a. Connect the HBA to Expander Mini-SAS X cable (788456-001) from the Host Bus Adapter to the Expander card. Connect port 1 to port 1 and port 2 to port 2.

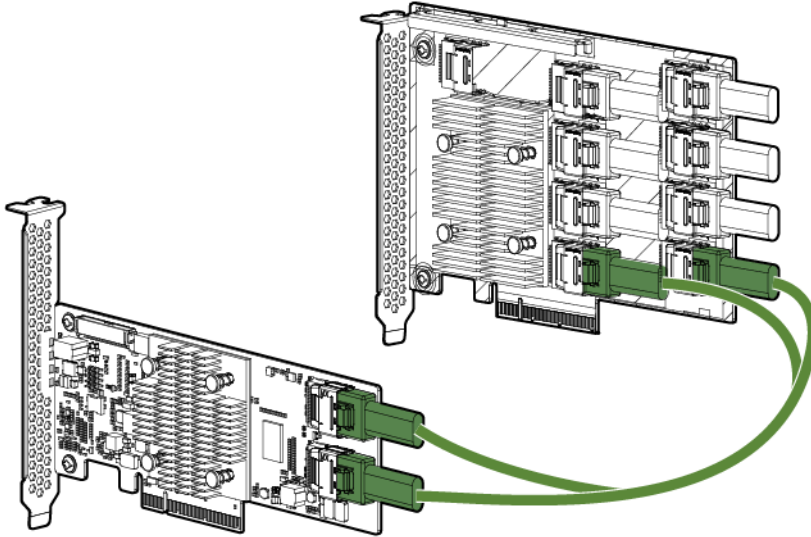

- b. Connect the Smart Array to Expander Mini-SAS Y cable (779300-001) from the Smart Array controller to the Expander card ports 1 and 2.

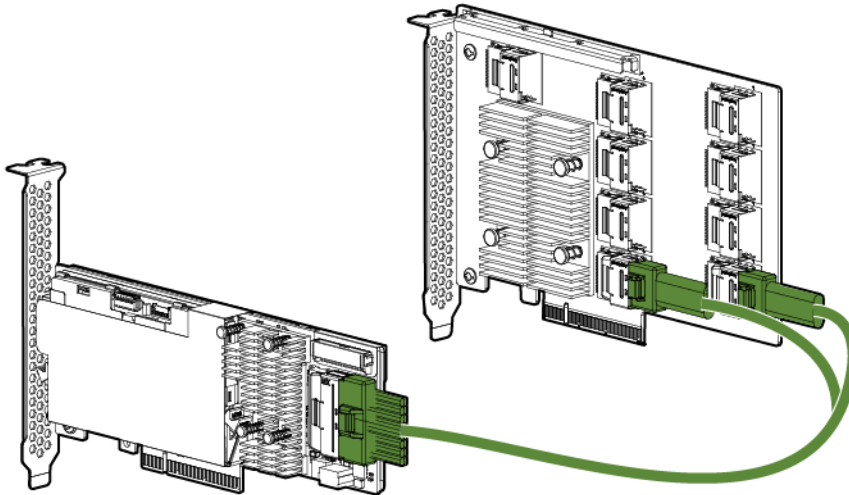

12. Connect the three Expander to backplane Mini-SAS X cables (778556-001) from the Expander card to each backplane according to the table below:

Expander connectors	LFF configuration	SFF configuration
Port 3 Port 4	Box 1	Box 4
Port 5 Port 6	Box 2	Box 5
Port 7 Port 8	Box 3	Box 6

13. Connect each end of the three Mini-SAS X cables to the matching port on each drive box backplane. Connect port 1 to port 1 and port 2 to port 2 for each cable set.
14. Install the storage controller into PCIe slot 1 or 3.
15. Install the Expander card into PCIe slot 2.
16. Route the cables and secure them under the cable clips.
 - o SFF configuration

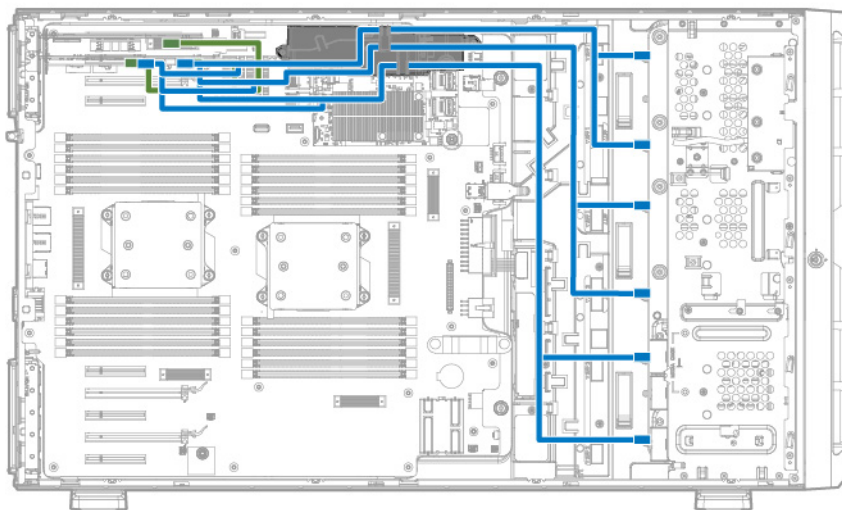

- o LFF configuration

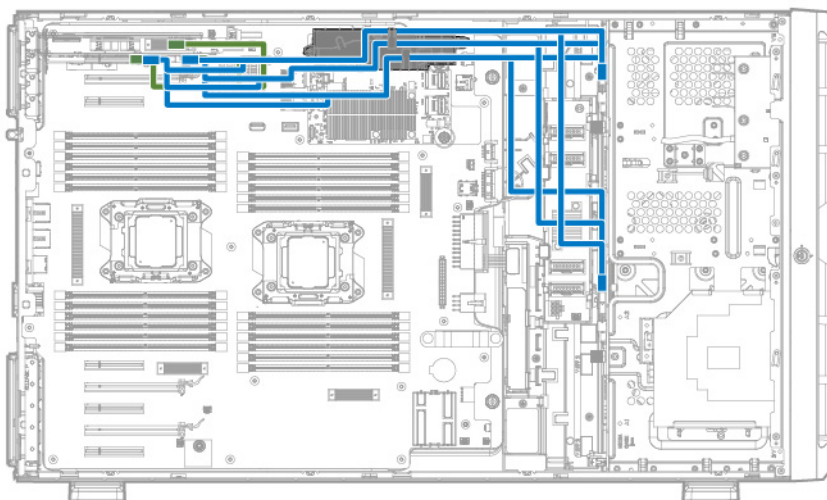

17. Replace the existing drive numbering label on the outside of the chassis with the appropriate label included. For more information, see Device numbering (on page 19).
18. Close the slot cover retainer.
19. Install the fan cage (on page 38).
20. Install the air baffle (on page 35).
21. Install the access panel (on page 33).
22. Do one of the following:
 - o If the server is in a tower configuration, return the server to an upright position.

- If the server is in a rack configuration, slide the server into the rack.
- 23. Connect each power cord to the server.
- 24. Connect each power cord to the power source.
- 25. Power up the server ("[Powering up the server](#)" on page 30).
- 26. Do one of the following:
 - For tower models, install the tower bezel (on page 31).
 - For rack models, install the security bezel ("[Security bezel option](#)" on page 50).

Installing a second SAS Expander card

The second SAS Expander card must be used with an HPE Smart Array P840 controller, first SAS Expander, second processor, and the x4 redundant power supply options all installed in the server.

To install the component:

1. Back up all server data.
2. Do one of the following:
 - For tower models, open and remove the tower bezel ("[Remove the tower bezel](#)" on page 31).
 - For rack models, if installed, remove the security bezel ("[Remove the security bezel \(optional\)](#)" on page 31).
3. Power down the server (on page 30).
4. Remove all power:
 - a. Disconnect each power cord from the power source.
 - b. Disconnect each power cord from the server.
5. Do one of the following:
 - For tower models, place the server on a flat, level surface with the access panel facing up.
 - For rack models, extend the server from the rack (on page 34).
6. Remove the access panel (on page 32).
7. Remove the air baffle (on page 34).
8. Remove the fan cage (on page 37).
9. Identify the ports on the second SAS expander card.



- Connect the 1000 mm Smart Array to the Expander Mini-SAS Y cable (778559-001) from the P840 Smart Array controller (port 1I) to the second SAS Expander card ports 1 and 2.

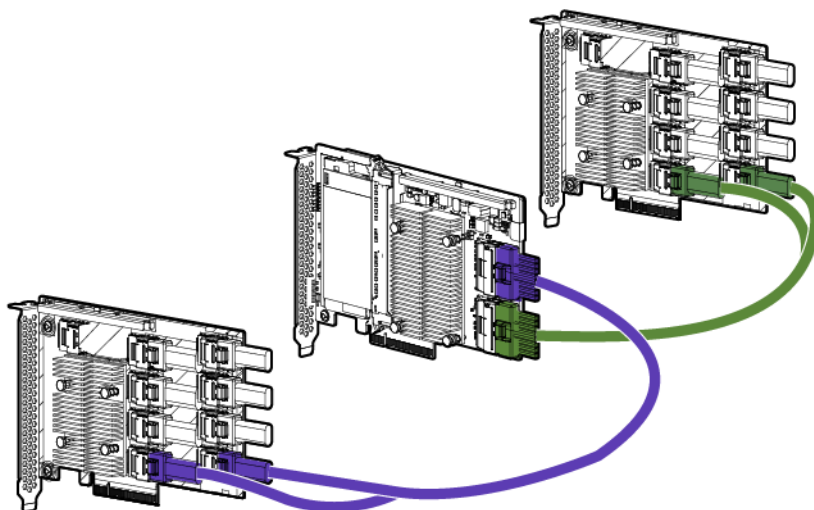

- Connect the three Expander to backplane Mini-SAS X cables (788453-001, 788454-001, 788455-001) from the second SAS Expander card to each backplane according to the table below:

SAS Expander connector	First SAS Expander (P840 port 2I)	Second SAS Expander (P840 port 1I)
Port 3 Port 4	Box 4	Box 1 (600 mm, 788453-001, drives 1-8)
Port 5 Port 6	Box 5	Box 2 (720 mm, 788454-001, drives, 9-16)
Port 7 Port 8	Box 6	Box 3 (820mm, 788455-001, drives 17-24)

- Connect each end of the three Mini-SAS X cables to the matching port on each drive box backplane. Connect port 1 to port 1 and port 2 to port 2 for each cable set.

13. Remove the expansion slot retainer cover and the slot blank.

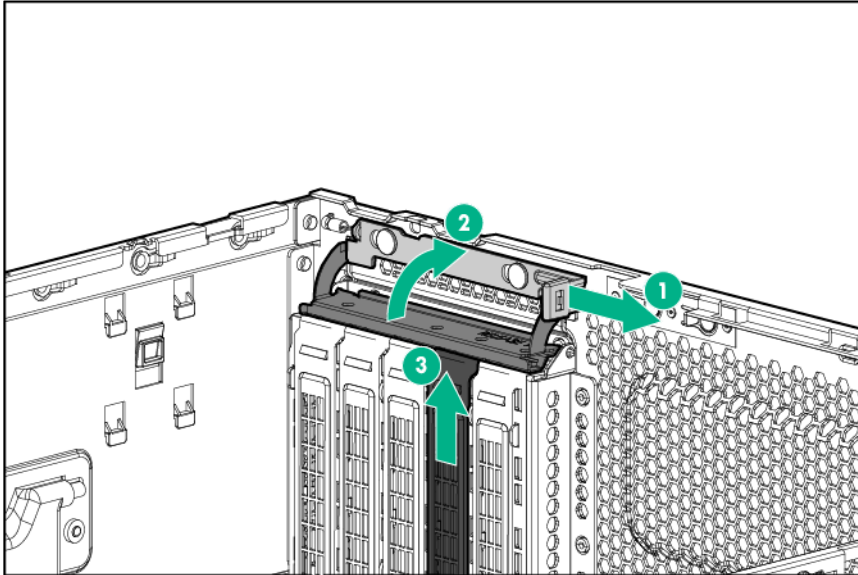

14. Install the second SAS Expander card into PCIe slot 9.
15. Close the slot retainer cover.
16. Route the cables and secure them under the cable clips.

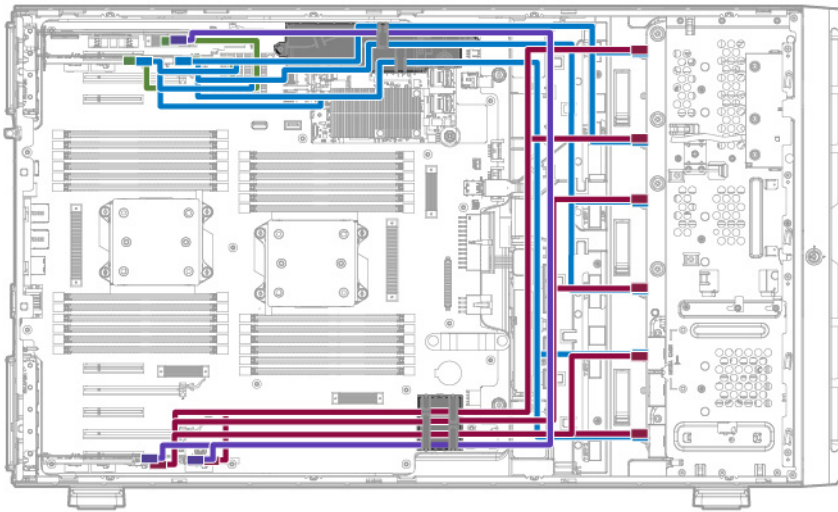

17. Install the fan cage (on page 38).
18. Install the air baffle (on page 35).
19. Install the access panel (on page 33).
20. Do one of the following:
 - o If the server is in a tower configuration, return the server to an upright position.
 - o If the server is in a rack configuration, slide the server into the rack.
21. Connect each power cord to the server.
22. Connect each power cord to the power source.
23. Power up the server ("Powering up the server" on page 30).
24. Do one of the following:

- For tower models, install the tower bezel (on page 31).
- For rack models, install the security bezel ("[Security bezel option](#)" on page 50).

SAS Expander configurations

A SAS expander treats all attached devices as one Box. Bay/drive numbering is determined by the attached SAS expander port.

SAS Expanders	Controller	Port	Connection	Box	Drive/Bay numbering	Total drives
1 SAS Expander	P440 Smart Array or H240 HBA	port 1	SAS Expander	box 1	1-24	24 LFF or SFF
2 SAS Expanders	P840 Smart Array	port 1 port 2	SAS Expander	box 1	1-24	48 SFF

Installing the HPE NVMe Express bay

The Express bay option includes a 6 NVMe SSD Express bay drive cage backplane and an Express bay bridge card.

An x4 Redundant Power Supply kit is required when four or more drive cages, including the Express bay drive kit, are installed in the server.

The Express drive bay supports 400 GB, 800 GB, 1.2 TB NVMe SSD drives. The HPE NVMe Express drive bay may be installed in bay 1 or 4 of an SFF model.

For more information about NVMe SSDs, see the Hewlett Packard Enterprise website (http://www.hpe.com/support/NVMeDrive_en).

For more information on supported drives, see the Hewlett Packard Enterprise website (<http://www.hpe.com/info/gs>).

⚠ CAUTION: To prevent damage to electrical components, take the appropriate anti-static precautions before beginning any system installation. Improper grounding can cause electrostatic discharge.

To install the option:

1. Back up all server data.
2. Do one of the following:
 - For tower models, open and remove the tower bezel ("[Remove the tower bezel](#)" on page 31).
 - For rack models, if installed, remove the security bezel ("[Remove the security bezel \(optional\)](#)" on page 31).
3. Power down the server (on page 30).
4. Remove all power:
 - a. Disconnect each power cord from the power source.
 - b. Disconnect each power cord from the server.
5. Do one of the following:
 - For tower models, place the server on a flat, level surface with the access panel facing up.
 - For rack models, extend the server from the rack (on page 34).
6. Remove the access panel (on page 32).
7. Remove the air baffle (on page 34).
8. Remove the fan cage (on page 37).

9. Install the Express bay drive cage assembly:
 - a. Remove the drive cage blank from box 1 or 4.

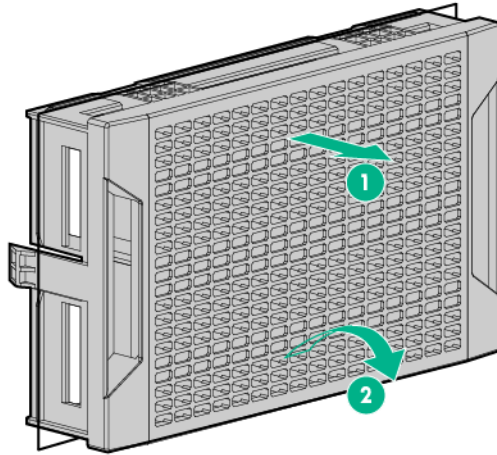

- b. Install the Express bay drive cage and backplane assembly.

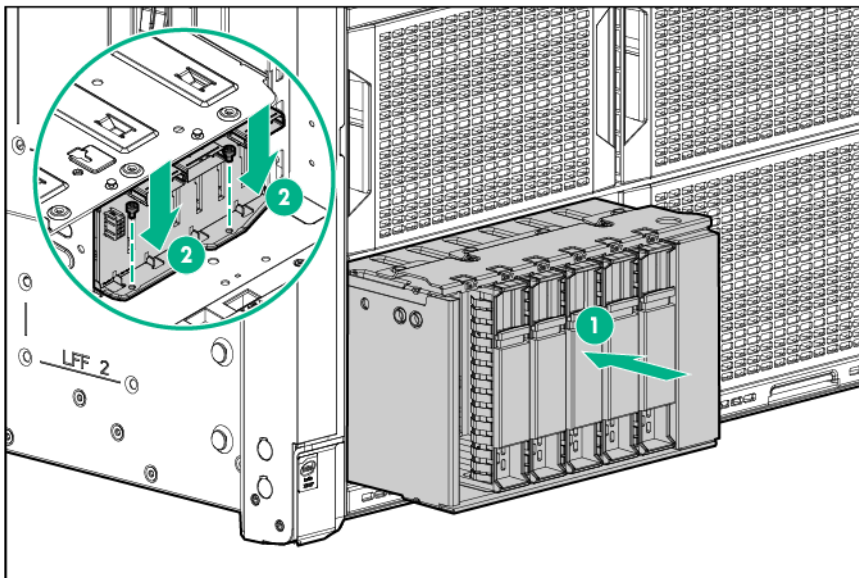

- c. Connect the 2x4 connector of the power Y-cable to the Express bay drive cage backplane.
 - d. Connect the other two ends of the power Y-cable to the cable connectors from the server power supply backplane.
 - e. Connect the three Express bay data cables to the Express bay drive cage backplane.
 10. Install the Express bay bridge card in PCIe slot 3, 6, or 8:

NOTE: A second processor must be installed if the Express bay bridge card is installed in PCIe slot 6 or 8.

- a. Remove the expansion slot retainer cover and the slot blank.

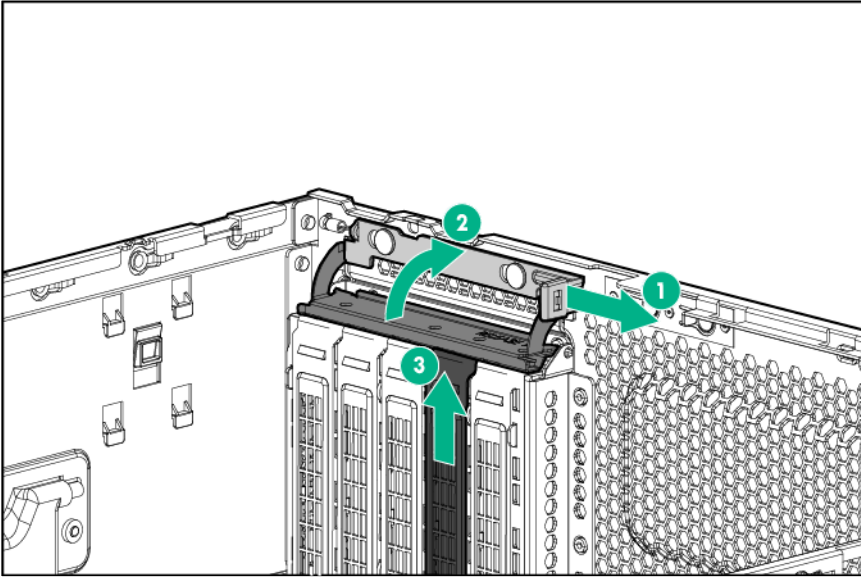

- b. Install the Express bay bridge card.

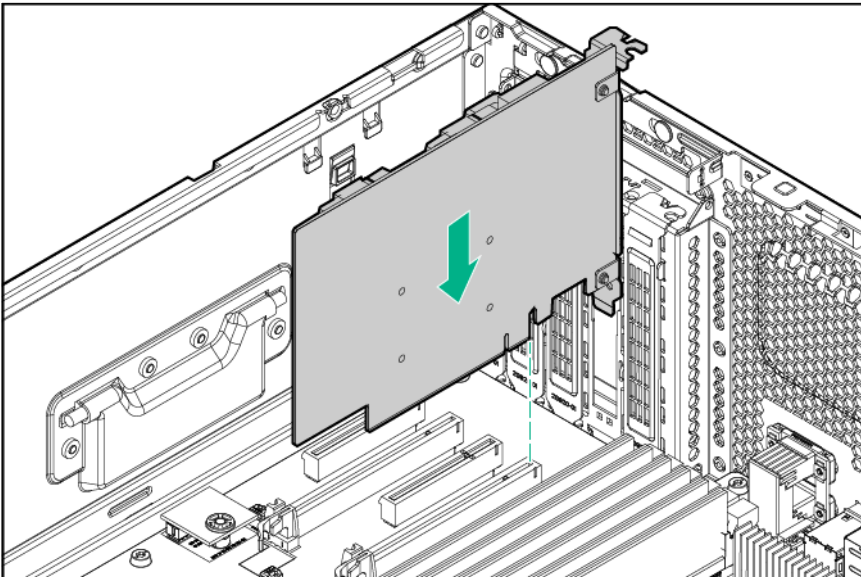

- c. Close the PCI slot cover retainer.
- d. Connect the Express bay data cables to the corresponding ports on the Express bay bridge card.

— Cable routing if the Express bay bridge card is installed in PCIe slot 3

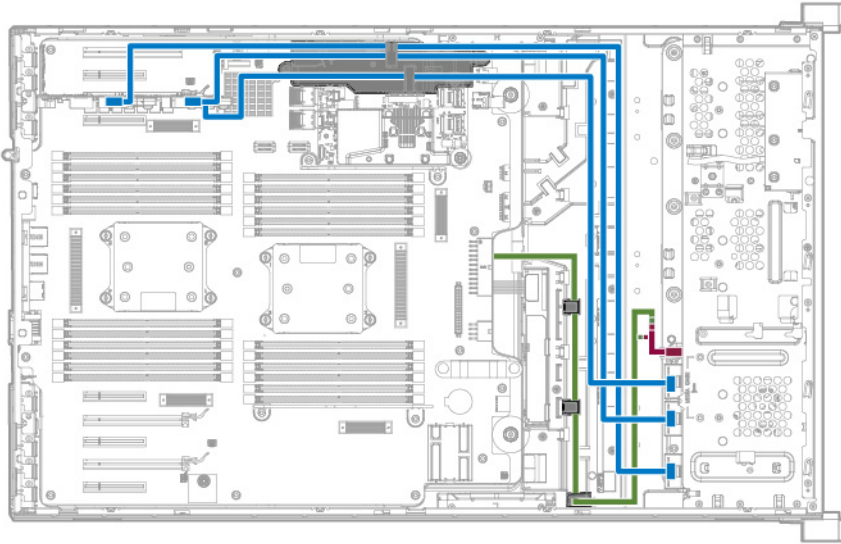

— Cable routing if a second processor is installed and the express bay bridge card is installed in PCIe slot 6 or 8

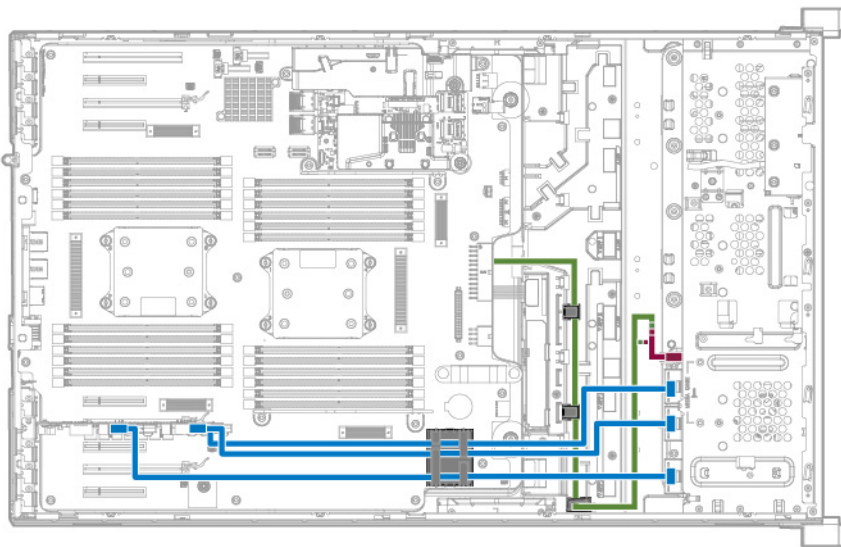

11. To ensure proper thermal cooling, adhere airflow covers to the outside of all drive cage blanks.
 - a. Remove all drive cage blanks.

- b. Install an airflow cover onto each drive cage blank, leaving only the top two rows of venting exposed.

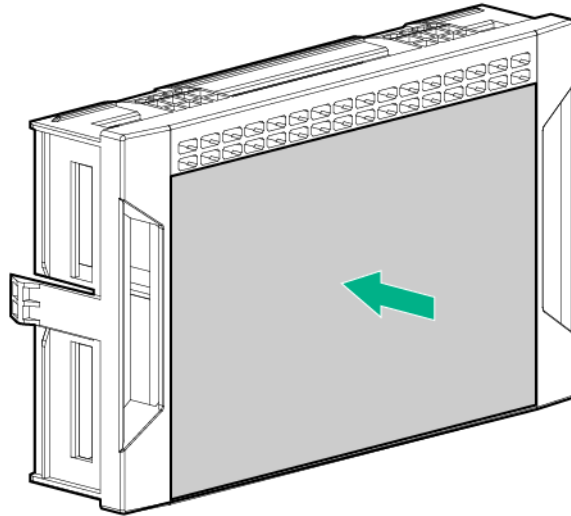

- c. Install the drive cage blanks.
12. Install the NVMe SSD drives ("[Installing NVMe drives](#)" on page 60).
13. Install the fan cage (on page 38).
14. Install the air baffle (on page 35).
15. Install the access panel (on page 33).
16. Do one of the following:
 - o If the server is in a tower configuration, return the server to an upright position.
 - o If the server is in a rack configuration, slide the server into the rack.
17. Connect each power cord to the server.
18. Connect each power cord to the power source.
19. Power up the server ("[Powering up the server](#)" on page 30).
20. Do one of the following:
 - o For tower models, install the tower bezel (on page 31).
 - o For rack models, install the security bezel ("[Security bezel option](#)" on page 50).

Optical drive option

1. Back up all server data.
2. Do one of the following:
 - o For tower models, open and remove the tower bezel ("[Remove the tower bezel](#)" on page 31).
 - o For rack models, if installed, remove the security bezel ("[Remove the security bezel \(optional\)](#)" on page 31).
3. Power down the server (on page 30).
4. Remove all power:
 - a. Disconnect each power cord from the power source.
 - b. Disconnect each power cord from the server.
5. Do one of the following:
 - o For tower models, place the server on a flat, level surface with the access panel facing up.

- o For rack models, extend the server from the rack (on page 34).
- 6. Remove the access panel (on page 32).
- 7. Using a Philips #1 screwdriver, remove the 9.5 mm optical drive rear side carrier.

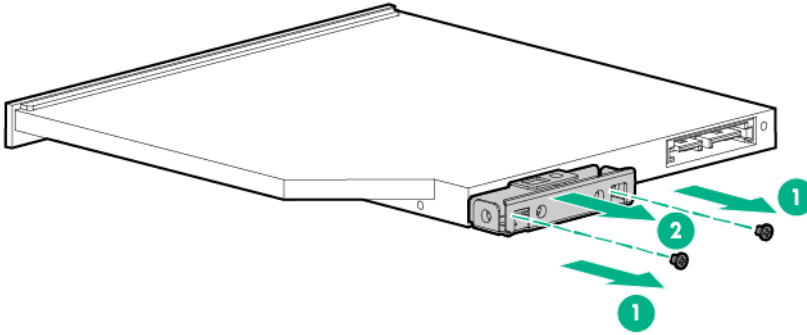

- 8. Remove the optical drive blank from the front panel:
 - a. Open the latch securing the drive blank.
 - b. Push out the blank from inside the server, and then remove it from the front panel.

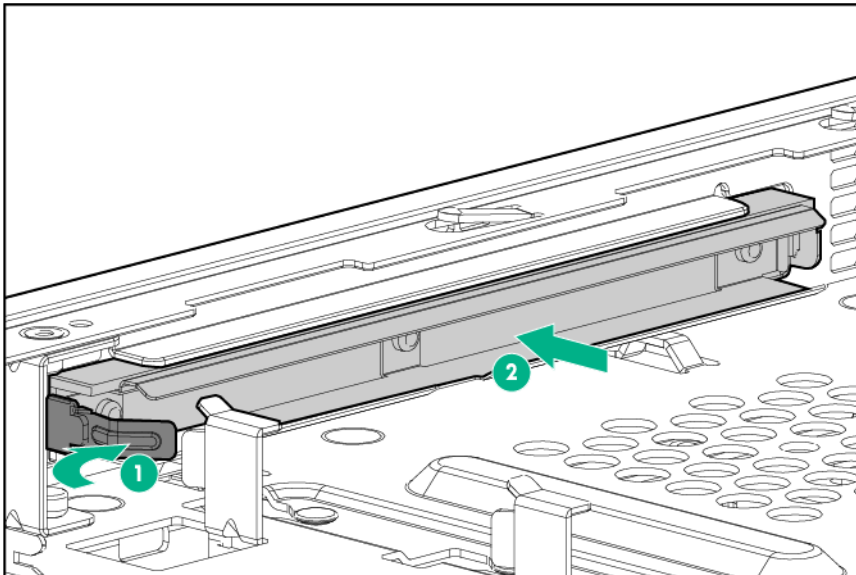

9. Remove the screw from the optical drive carrier.

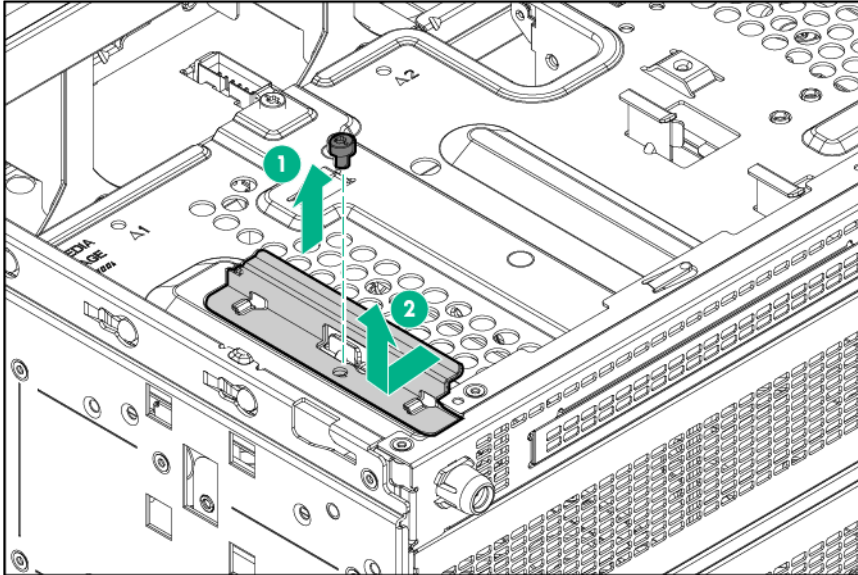

10. Remove the optical drive carrier.
11. Install the 9.5mm optical drive into the optical drive carrier.
12. Tighten the screws on the optical drive carrier.
13. Connect the SATA and power cables to the optical drive.
 - o LFF configuration

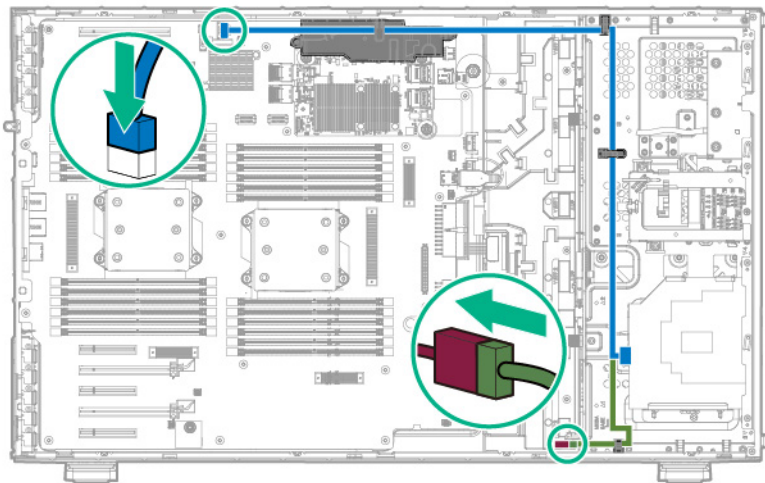

- o SFF configuration

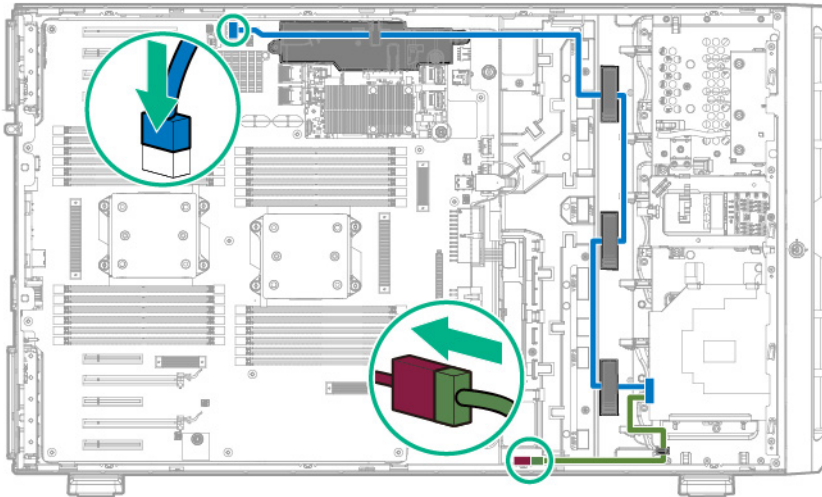

14. Install the access panel (on page 33).
15. Do one of the following:
 - o If the server is in a tower configuration, return the server to an upright position.
 - o If the server is in a rack configuration, slide the server into the rack.
16. Connect each power cord to the server.
17. Connect each power cord to the power source.
18. Power up the server ("Powering up the server" on page 30).
19. Do one of the following:
 - o For tower models, install the tower bezel (on page 31).
 - o For rack models, install the security bezel ("Security bezel option" on page 50).

Processor option

The server supports single and dual-processor operations. When a second processor is installed, fan 1 must also be installed. For more information, see "Hot-plug fans (on page 28)."

To upgrade from E5-2600 v3 processor(s) to E5-2600 v4 processor(s), see Customer Advisory (c04849981) (<http://h20564.www2.hp.com/hpsc/doc/public/display?docId=c04849981>).

For more information about product features, specifications, options, configurations, and compatibility, see the product QuickSpecs on the Hewlett Packard Enterprise website (<http://www.hp.com/info/gs>).

Processor installation cautions

The server supports single-processor and dual-processor operations.

CAUTION: To avoid damage to the processor and system board, only authorized personnel should attempt to replace or install the processor in this server.

CAUTION: To prevent possible server overheating, always populate each processor socket with a processor socket cover and a processor blank, or a processor and a heatsink.

CAUTION: To prevent possible server malfunction and damage to the equipment, multiprocessor configurations must contain processors with the same part number.

IMPORTANT: If installing a processor with a faster speed, update the system ROM before installing the processor.

IMPORTANT: Processor socket 1 must be populated at all times or the server does not function.

For optimum performance, Hewlett Packard Enterprise recommends:

- Use DIMMs that match the speed of the processor installed in the server. Intel Xeon E5-2600 v4 processors are optimized to work with 2400 MHz DIMMs.
- In a multiprocessor configuration, balance the total capacity of the DIMMs across the processors.

Installing a second processor

1. Back up all server data.
2. Do one of the following:
 - For tower models, open and remove the bezel.
 - For rack models, if installed, remove the security bezel ("[Remove the security bezel \(optional\)](#)" on page 31).
3. Power down the server (on page 30).
4. Remove all power:
 - a. Disconnect each power cord from the power source.
 - b. Disconnect each power cord from the server.
5. Do one of the following:
 - For tower models, place the server on a flat, level surface with the access panel facing up.
 - For rack models, extend the server from the rack (on page 34).
6. Remove the access panel (on page 32).
7. Remove the air baffle (on page 34).
8. Open each of the processor locking levers in the order indicated in the following illustration, and then open the processor retaining bracket.

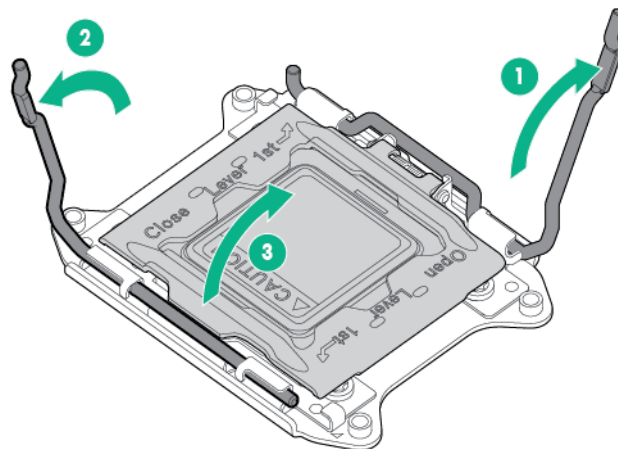

9. Remove the clear processor socket cover. Retain the processor socket cover for future use.

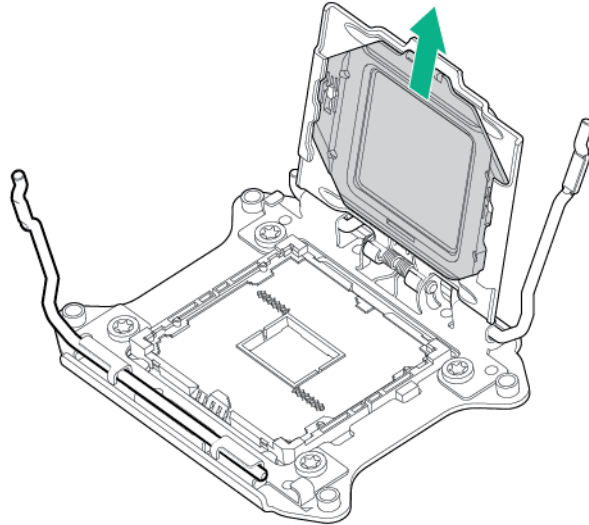

CAUTION: THE PINS ON THE SYSTEM BOARD ARE VERY FRAGILE AND EASILY DAMAGED. To avoid damage to the system board, do not touch the processor or the processor socket contacts.

10. Install the processor. Verify that the processor is fully seated in the processor retaining bracket by visually inspecting the processor installation guides on either side of the processor. **THE PINS ON THE SYSTEM BOARD ARE VERY FRAGILE AND EASILY DAMAGED.**

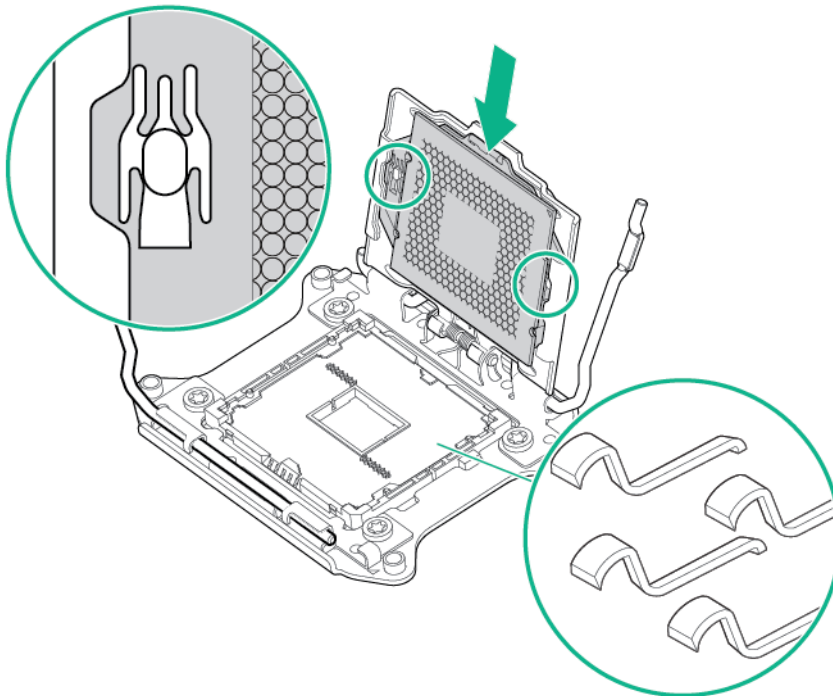

11. Close the processor retaining bracket. When the processor is installed properly inside the processor retaining bracket, the processor retaining bracket clears the flange on the front of the socket.

CAUTION: Do not press down on the processor. Pressing down on the processor might damage the processor socket and the system board. Press only in the area indicated on the processor retaining bracket.

12. Press and hold the processor retaining bracket in place, and then close each processor locking lever. Press only in the area indicated on the processor retaining bracket.

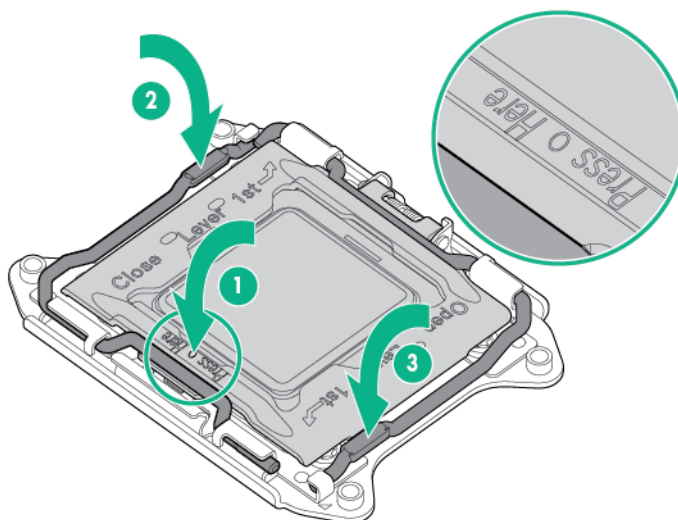

CAUTION: Close and hold down the processor cover socket while closing the processor locking levers. The levers should close without resistance. Forcing the levers closed can damage the processor and socket, requiring system board replacement.

13. Remove the heatsink cover.

CAUTION: After the cover is removed, do not touch the thermal interface media.

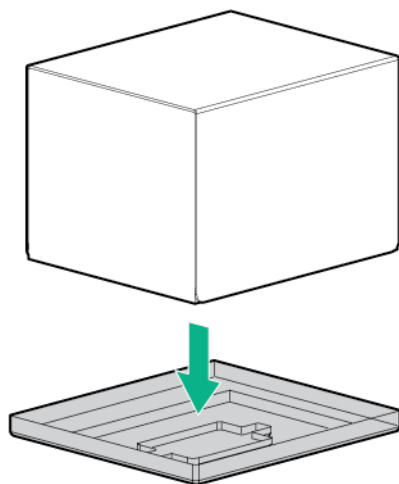

14. Install the heatsink:
 - a. Position the heatsink on the processor backplate.
 - b. Tighten one pair of diagonally opposite screws halfway, and then tighten the other pair of screws.

c. Finish the installation by completely tightening the screws in the same sequence.

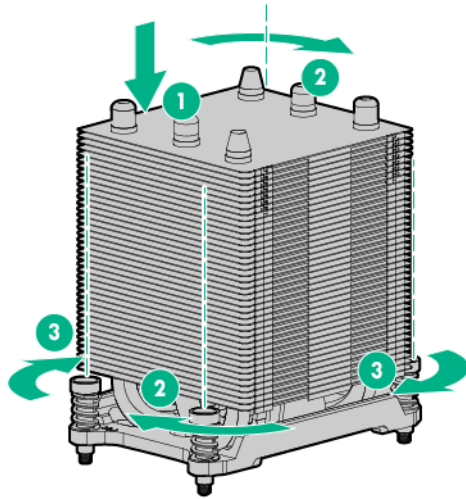

15. Install the air baffle (on page 35).
16. Remove the fan blank from fan bay 1.

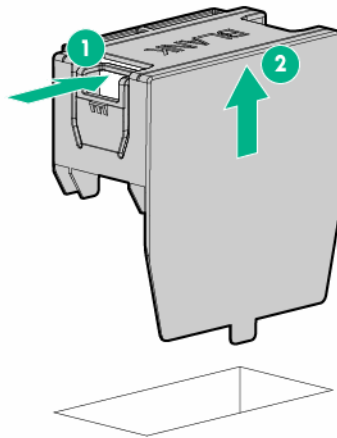

17. Install the fan in fan bay 1, making sure that the fan clicks into place.

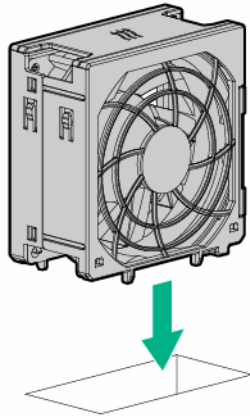

18. Install the access panel (on page 33).
19. Do one of the following:
 - o If the server is in a tower configuration, return the server to an upright position.
 - o If the server is in a rack configuration, slide the server into the rack.
20. Connect each power cord to the server.
21. Connect each power cord to the power source.
22. Power up the server ("Powering up the server" on page 30).
23. Do one of the following:
 - o For tower models, install the tower bezel (on page 31).
 - o For rack models, install the security bezel ("Security bezel option" on page 50).

Redundant fan option

To provide sufficient airflow to the system if a fan fails, the server supports redundant fans.

For more information about product features, specifications, options, configurations, and compatibility, see the product QuickSpecs on the Hewlett Packard Enterprise website (<http://www.hpe.com/info/qs>).

To install the component:

1. Do one of the following:
 - o For tower models, open and remove the tower bezel ("Remove the tower bezel" on page 31).
 - o For rack models, if installed, remove the security bezel ("Remove the security bezel (optional)" on page 31).
2. Power down the server (on page 30).
3. Remove all power:
 - a. Disconnect each power cord from the power source.
 - b. Disconnect each power cord from the server.
4. Do one of the following:
 - o For tower models, place the server on a flat, level surface with the access panel facing up.
 - o For rack models, extend the server from the rack (on page 34).

5. Remove the access panel (on page 32).
6. Remove the fan blank.

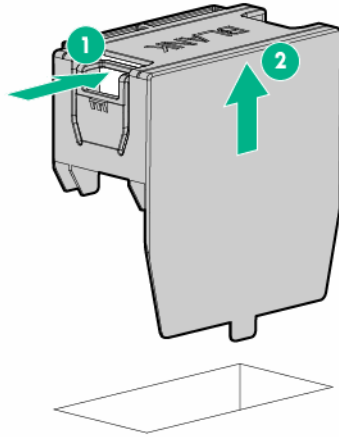

7. Install the fan, making sure that the fan clicks into place.

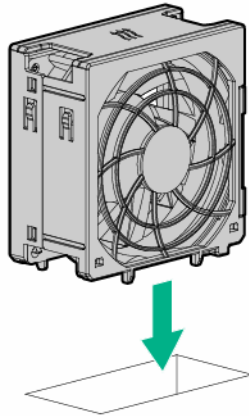

8. Install the PCIe air baffles.

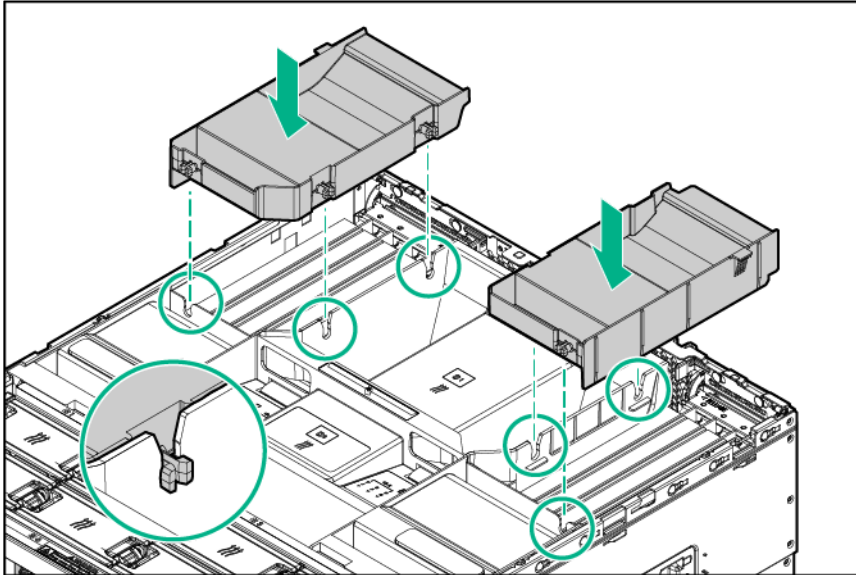

9. Install the access panel (on page 33).
10. Do one of the following:
 - o If the server is in a tower configuration, return the server to an upright position.
 - o If the server is in a rack configuration, slide the server into the rack.
11. Connect each power cord to the server.
12. Connect each power cord to the power source.
13. Power up the server ("Powering up the server" on page 30).
14. Do one of the following:
 - o For tower models, install the tower bezel (on page 31).
 - o For rack models, install the security bezel ("Security bezel option" on page 50).

Memory options



IMPORTANT: This server does not support mixing LRDIMMs and RDIMMs. Attempting to mix any combination of these DIMMs can cause the server to halt during BIOS initialization.

The memory subsystem in this server can support LRDIMMs or RDIMMs:

- RDIMMs offer address parity protection.
- LRDIMMs support higher densities than single-rank and dual-rank RDIMMs. This support enables you to install higher capacity DIMMs, resulting in higher system capacities and higher bandwidth.

All types are referred to as DIMMs when the information applies to all types. When specified as LRDIMM or RDIMM, the information applies to that type only. All memory installed in the server must be of the same type.

Memory-processor compatibility information

For the latest memory configuration information, see the product QuickSpecs on the Hewlett Packard Enterprise website (<http://www.hpe.com/info/qs>).

DIMM types

- Intel Xeon E5-2600 v3 processors are optimized for:
 - Single-rank and dual-rank PC4-2133 (DDR4-2133) RDIMMs operating at up to 2133 MT/s
 - Dual-rank and quad-rank PC4-2133 (DDR4-2133) LRDIMMs operating at up to 2133 MT/s
- Intel Xeon E5-2600 v4 processors are optimized for:
 - Single-rank and dual-rank PC4-2400T (DDR4-2400) RDIMMs operating at up to 2400 MT/s
 - Dual-rank and quad-rank PC4-2400T (DDR4-2400) LRDIMMs operating at up to 2400 MT/s

DIMM specifications

DIMM specifications - Intel Xeon E5-2600 v3 processor installed

Type	Rank	Capacity (GB)	Native speed (MT/s)	Voltage
RDIMM	Single	4	2133	STD
RDIMM	Single	8	2133	STD
RDIMM	Dual	8	2133	STD
RDIMM	Dual	16	2133	STD
LRDIMM	Dual	16	2133	STD
LRDIMM	Quad	32	2133	STD

DIMM specifications - Intel Xeon E5-2600 v4 processor installed

Type	Rank	Capacity (GB)	Native speed (MT/s)	Voltage
RDIMM	Single	4	2400	STD
RDIMM	Single	8	2400	STD
RDIMM	Single	16	2400	STD
RDIMM	Dual	16	2400	STD
RDIMM	Dual	32	2400	STD
LRDIMM	Dual	32	2400	STD
LRDIMM	Quad	64	2400	STD

Populated DIMM speed (MT/s)

Operating memory speed is a function of rated DIMM speed, the number of DIMMs installed per channel, processor model, and the speed selected in the BIOS/Platform Configuration (RBSU) of the UEFI System Utilities ("[UEFI System Utilities](#)" on page 154).

Populated DIMM speed - Intel Xeon E5-2600 v3 processor installed

Type	Rank	1 DIMM per channel (MT/s)	2 DIMMs per channel (MT/s)	3 DIMMs per channel (MT/s)
RDIMM	Single	2133	2133	1866
RDIMM	Dual	2133	2133	1866
LRDIMM	Quad	2133	2133	1866

Populated DIMM speed - Intel Xeon E5-2600 v4 processor installed

Type	Rank	1 DIMMs per channel (MT/s)	2 DIMMs per channel (MT/s)	3 DIMMs per channel (MT/s)
RDIMM	Single	2400	2133	1866
RDIMM	Dual	2400	2400	1866
LRDIMM	Quad	2400	2400	2133

Maximum memory capacity

Maximum memory capacity is a function of DIMM capacity, number of installed DIMMs, memory type, and number of installed processors.

Maximum memory capacity - Intel Xeon E5-2600 v3 processor installed

DIMM type	DIMM rank	Capacity (GB)	Maximum capacity for one processor (GB)	Maximum capacity for two processors (GB)
RDIMM	Single-rank	4	48	96
RDIMM	Single-rank	8	96	192
RDIMM	Dual-rank	8	96	192
RDIMM	Dual-rank	16	192	384
LRDIMM	Dual-rank	16	192	384
LRDIMM	Quad-rank	32	384	768

Maximum memory capacity - Intel Xeon E5-2600 v4 processor installed

DIMM type	DIMM rank	Capacity (GB)	Maximum capacity for one processor (GB)	Maximum capacity for two processors (GB)
RDIMM	Single-rank	4	32	64
RDIMM	Single-rank	8	64	128
RDIMM	Single-rank	16	64	128
RDIMM	Dual-rank	16	128	256
RDIMM	Dual-rank	32	256	512
LRDIMM	Dual-rank	32	256	512
LRDIMM	Quad-rank	64	512	1024

SmartMemory

SmartMemory authenticates and unlocks certain features available only on Qualified memory and verifies whether installed memory has passed Hewlett Packard Enterprise qualification and test processes. Qualified memory is performance-tuned for ProLiant and BladeSystem servers and provides future enhanced support through Active Health and manageability software.

Memory subsystem architecture

The memory subsystem in this server is divided into channels. Each processor supports four channels, and each channel supports three DIMM slots.

Memory subsystem channel	Population order	Slot number (Processor 2)	Slot number (Processor 1)
1	A	12	1
	E	11	2
	I	10	3
2	B	9	4
	F	8	5
	J	7	6
3	C	1	12
	G	2	11
	K	3	10

Memory subsystem channel	Population order	Slot number (Processor 2)	Slot number (Processor 1)
4	D	4	9
	H	5	8
	L	6	7

For the location of the slot numbers, see "DIMM slots (on page 17)."

This multi-channel architecture provides enhanced performance in Advanced ECC mode. This architecture also enables Online Spare Memory modes.

DIMM slots in this server are identified by number and by letter. Letters identify the population order. Slot numbers indicate the DIMM slot ID for spare replacement.

Single-, dual-, and quad-rank DIMMs

To understand and configure memory protection modes properly, an understanding of single-, dual-, and quad-rank DIMMs is helpful. Some DIMM configuration requirements are based on these classifications.

A single-rank DIMM has one set of memory chips that is accessed while writing to or reading from the memory. A dual-rank DIMM is similar to having two single-rank DIMMs on the same module, with only one rank accessible at a time. A quad-rank DIMM is, effectively, two dual-rank DIMMs on the same module. Only one rank is accessible at a time. The server memory control subsystem selects the proper rank within the DIMM when writing to or reading from the DIMM.

Dual- and quad-rank DIMMs provide the greatest capacity with the existing memory technology. For example, if current DRAM technology supports 8-GB single-rank DIMMs, a dual-rank DIMM would be 16 GB, and a quad-rank DIMM would be 32 GB.

LRDIMMs are labeled as quad-rank DIMMs. There are four ranks of DRAM on the DIMM, but the LRDIMM buffer creates an abstraction that allows the DIMM to appear as a dual-rank DIMM to the system. The LRDIMM buffer isolates the electrical loading of the DRAM from the system to allow for faster operation. This allows higher memory operating speed compared to quad-rank RDIMMs.

DIMM identification

To determine DIMM characteristics, see the label attached to the DIMM and refer to the following illustration and table.

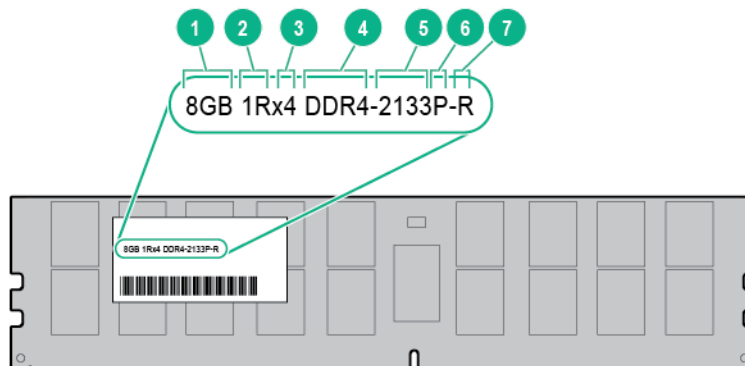

Item	Description	Definition
1	Capacity	8 GB 16 GB 32 GB

Item	Description	Definition
		64 GB
2	Rank	1R = Single-rank 2R = Dual-rank 4R = Quad-rank
3	Data width on DRAM	x4 = 4-bit x8 = 8-bit
4	Memory generation	DDR4
5	Maximum memory speed	2133 MT/s 2400 MT/s
6	CAS latency	P=15 T=17
7	DIMM type	R = RDIMM (registered) L = LRDIMM (load reduced)

For more information about product features, specifications, options, configurations, and compatibility, see the product QuickSpecs on the Hewlett Packard Enterprise website (<http://www.hpe.com/info/qs>).

Memory configurations

To optimize server availability, the server supports the following AMP modes:

- **Advanced ECC**—Provides up to 4-bit error correction. This mode is the default option for this server.
- **Online spare memory**—Provides protection against failing or degraded DIMMs. Certain memory is reserved as spare, and automatic failover to spare memory occurs when the system detects a DIMM that is degrading. This allows DIMMs that have a higher probability of receiving an uncorrectable memory error (which would result in system downtime) to be removed from operation.
- **Mirrored memory**—Provides maximum protection against failed DIMMs. Uncorrectable errors in one channel are corrected by the mirror channel.

Advanced Memory Protection options are configured in the BIOS/Platform Configuration (RBSU). If the requested AMP mode is not supported by the installed DIMM configuration, the server boots in Advanced ECC mode. For more information, see the *HPE UEFI System Utilities User Guide for HPE ProLiant Gen9 Servers* on the Hewlett Packard Enterprise website (<http://www.hpe.com/info/ProLiantUEFI/docs>).

Advanced ECC memory configuration

Advanced ECC memory is the default memory protection mode for this server. Standard ECC can correct single-bit memory errors and detect multi-bit memory errors. When multi-bit errors are detected using Standard ECC, the error is signaled to the server and causes the server to halt.

Advanced ECC protects the server against some multi-bit memory errors. Advanced ECC can correct both single-bit memory errors and 4-bit memory errors if all failed bits are on the same DRAM device on the DIMM.

Advanced ECC provides additional protection over Standard ECC because it is possible to correct certain memory errors that would otherwise be uncorrected and result in a server failure. Using HPE Advanced Memory Error Detection technology, the server provides notification when a DIMM is degrading and has a higher probability of uncorrectable memory error.

Online Spare memory configuration

Online spare memory provides protection against degraded DIMMs by reducing the likelihood of uncorrected memory errors. This protection is available without any operating system support.

Online spare memory protection dedicates one rank of each memory channel for use as spare memory. The remaining ranks are available for OS and application use. If correctable memory errors occur at a rate

higher than a specific threshold on any of the non-spare ranks, the server automatically copies the memory contents of the degraded rank to the online spare rank. The server then deactivates the failing rank and automatically switches over to the online spare rank.

Mirrored memory configuration

Mirroring provides protection against uncorrected memory errors that would otherwise result in server downtime. Mirroring is performed at the channel level to one memory channel pair that can be either:

- Channel 1 data being mirrored in channel 2
- Channel 3 data being mirrored in channel 4

If an uncorrectable error is detected in the active memory channel, data is retrieved from the mirror channel. This channel becomes the new active channel, and the system disables the channel with the failed DIMM.

General DIMM slot population guidelines

Observe the following guidelines for all AMP modes:

- Install DIMMs that are optimized for the installed processor ("[Memory-processor compatibility information](#)" on page 97).
To identify the processor type installed in the server, use the BIOS/Platform Configuration (RBSU) of the UEFI System Utilities ("[Identifying the processor type](#)" on page 103).
- Install DIMMs only if the corresponding processor is installed.
- Do not mix LRDIMMs and RDIMMs.
- White DIMM slots denote the first slot of a channel (Ch 1-A, Ch 2-B, Ch 3-C, Ch 4-D).
- When only one processor is installed, install DIMMs in sequential alphabetic order: A, B, C, D, E, F, and so forth.
- When two processors are installed, install the DIMMs in sequential alphabetical order balanced between the two processors: P1-A, P2-A, P1-B, P2-B, P1-C, P2-C, and so forth.
- When single-rank, dual-rank, and quad-rank DIMMs are populated for two DIMMs per channel, always populate the higher number rank DIMM first (starting from the farthest slot). For example, first quad-rank DIMM, then dual-rank DIMM, and then lastly single-rank DIMM.
- DIMMs should be populated starting farthest from the processor on each channel.

For more information about server memory, see the Hewlett Packard Enterprise website (<http://www.hpe.com/info/memory>).

Advanced ECC population guidelines

For Advanced ECC mode configurations, observe the following guidelines:

- Observe the general DIMM slot population guidelines (on page 102).
- DIMMs may be installed individually.

Online spare population guidelines

For Online Spare memory mode configurations, observe the following guidelines:

- Observe the general DIMM slot population guidelines (on page 102).
- Each channel must have a valid online spare configuration.
- Each channel can have a different valid online spare configuration.

- Each populated channel must have a spare rank. A single dual-rank DIMM is not a valid configuration.

Mirrored Memory population guidelines

For Mirrored Memory mode configurations, observe the following guidelines:

- Observe the general DIMM slot population guidelines (on page 102).
- Install DIMMs in either channel 1 and channel 2, or channel 3 and channel 4. Installed DIMMs must be identical in terms of size and organization.
- In multi-processor configurations, each processor must have a valid Mirrored Memory configuration.

Identifying the processor type

The processor type installed in the server is briefly displayed during POST. To view this information and additional processor specifications, do the following:

1. Reboot the server.
The server restarts and the POST screen appears.
2. Press **F9**.
The System Utilities screen appears.
3. Select **System Information | Processor Information**.
The Processor Information screen shows detailed information about the processors installed in the server.
4. Press **Esc** until the main menu is displayed.
5. Select **Reboot the System** to exit the utility and resume the boot process.

Installing a DIMM



CAUTION: To avoid damage to the hard drives, memory, and other system components, the air baffle, drive blanks, and access panel must be installed when the server is powered up.

To install the component:

1. Do one of the following:
 - For tower models, open and remove the tower bezel ("[Remove the tower bezel](#)" on page 31).
 - For rack models, if installed, remove the security bezel ("[Remove the security bezel \(optional\)](#)" on page 31).
2. Power down the server (on page 30).
3. Remove all power:
 - a. Disconnect each power cord from the power source.
 - b. Disconnect each power cord from the server.
4. Do one of the following:
 - For tower models, place the server on a flat, level surface with the access panel facing up.
 - For rack models, extend the server from the rack (on page 34).
5. Remove the access panel (on page 32).
6. Remove the air baffle (on page 34).
7. Open the DIMM slot latches.

8. Install the DIMM.

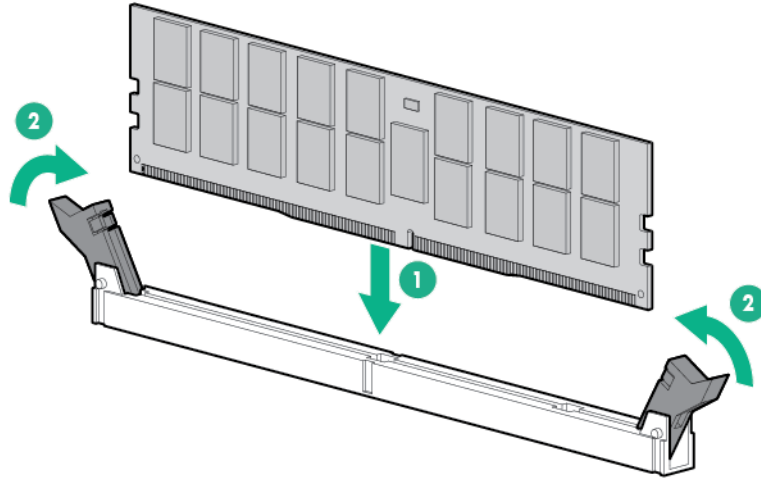

For more information about LEDs and troubleshooting failed DIMMs, see "Systems Insight Display LED combinations (on page 14)."

SFF media cage option

For more information about product features, specifications, options, configurations, and compatibility, see the product QuickSpecs on the Hewlett Packard Enterprise website (<http://www.hpe.com/info/gs>).

To install the component:

1. Do one of the following:
 - o For tower models, open and remove the tower bezel ("Remove the tower bezel" on page 31).
 - o For rack models, if installed, remove the security bezel ("Remove the security bezel (optional)" on page 31).
2. Power down the server (on page 30).
3. Remove all power:
 - a. Disconnect each power cord from the power source.
 - b. Disconnect each power cord from the server.
4. Do one of the following:
 - o For tower models, place the server on a flat, level surface with the access panel facing up.
 - o For rack models, extend the server from the rack (on page 34).
5. Remove the access panel (on page 32).
6. Remove the air baffle (on page 34).
7. Remove the fan cage (on page 37).

8. Remove the blanks from boxes 1 and 2.

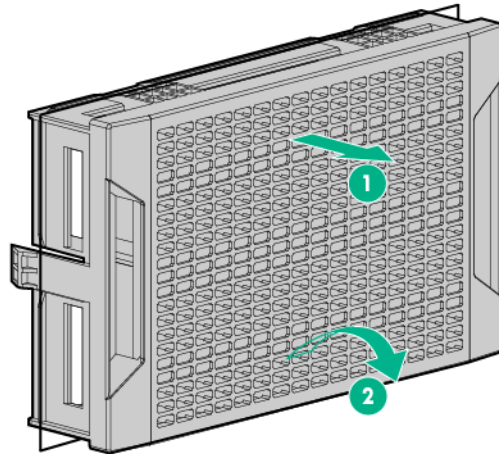

9. If the server is installed in a rack and has the SID option installed, then extend the SID module.

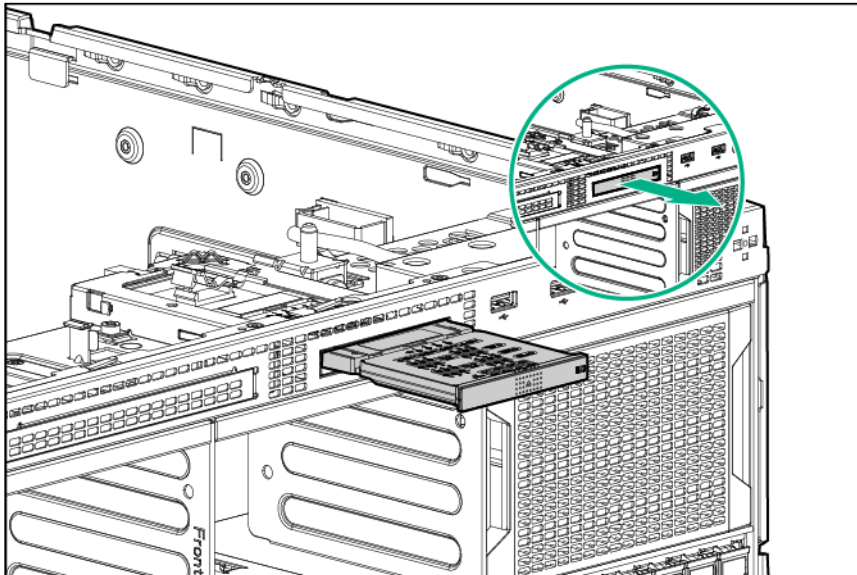

10. Remove the panel covers above boxes 1 and 2.

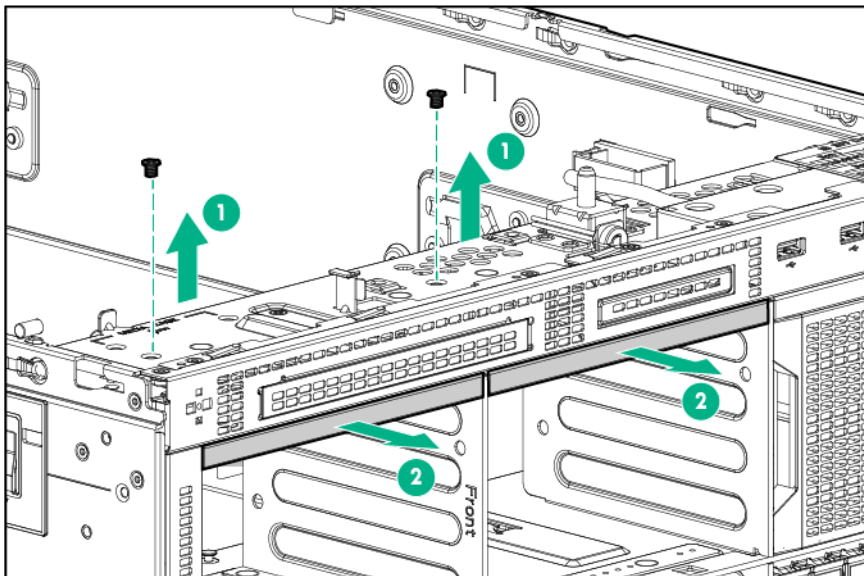

11. Remove the divider between boxes 1 and 2.

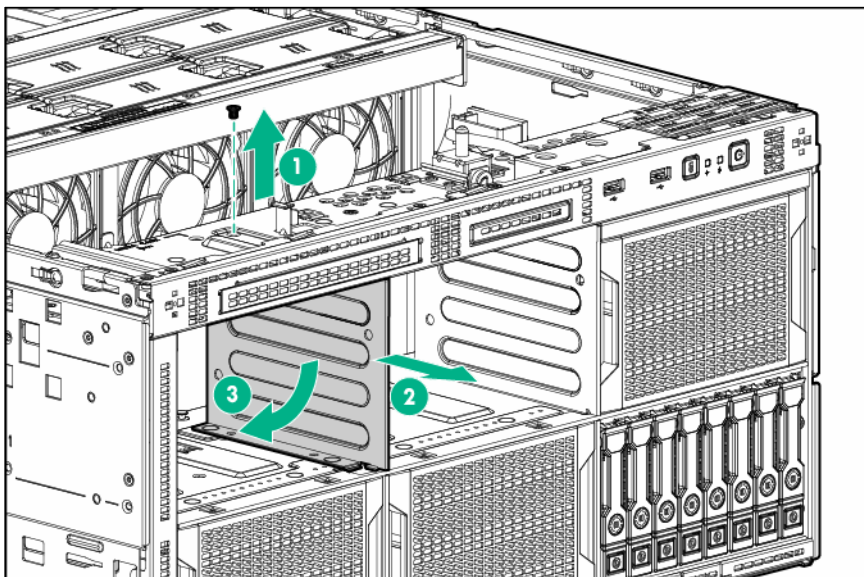

12. Install the media cage.

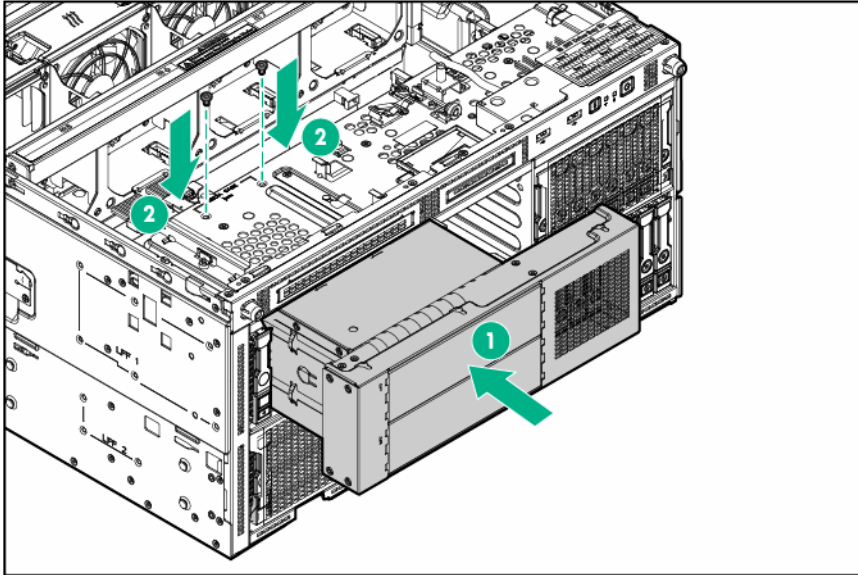

13. If extended, slide the Systems Insight Display back into the slot.

14. Install the media device.

15. Connect the SFF media power cable.

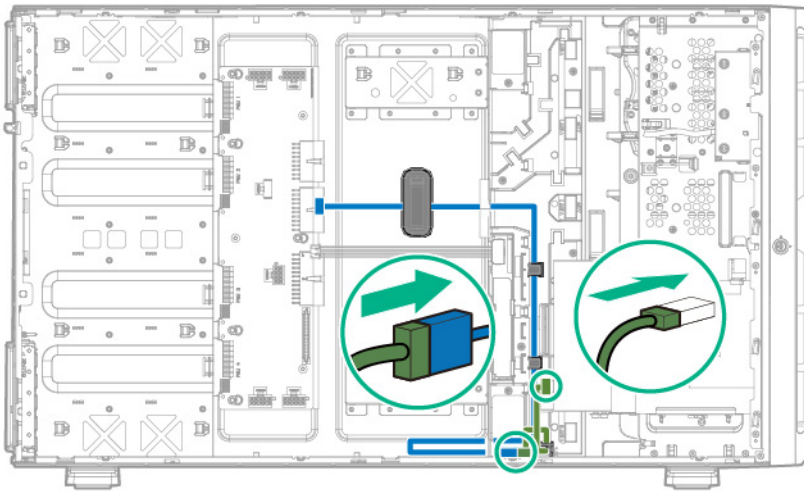

16. Connect the data cable to the media device.

Cable routing to connect a SATA device

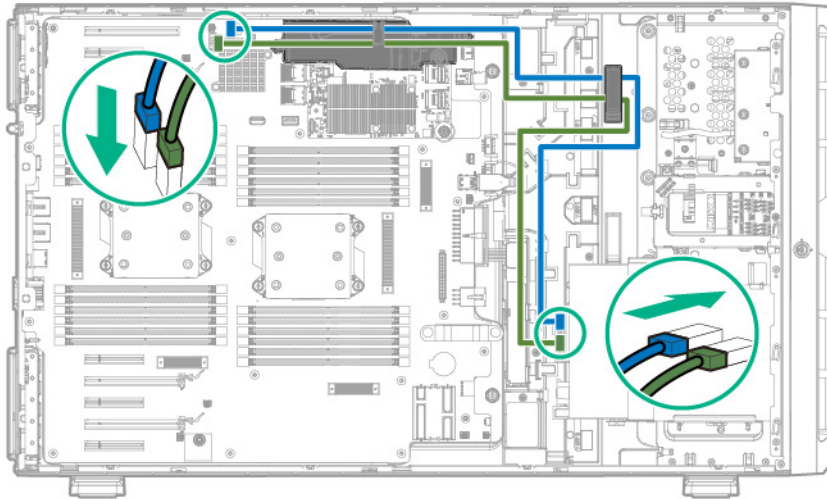

17. Install the fan cage (on page 38).
18. Install the air baffle (on page 35).
19. Install the access panel (on page 33).
20. Do one of the following:
 - If the server is in a tower configuration, return the server to an upright position.
 - If the server is in a rack configuration, slide the server into the rack.
21. Connect each power cord to the server.
22. Connect each power cord to the power source.
23. Power up the server ("Powering up the server" on page 30).
24. Do one of the following:
 - For tower models, install the tower bezel (on page 31).
 - For rack models, install the security bezel ("Security bezel option" on page 50).

LFF media cage option

For more information about product features, specifications, options, configurations, and compatibility, see the product QuickSpecs on the Hewlett Packard Enterprise website (<http://www.hpe.com/info/qs>).

To install the component:

1. Back up all server data.
2. Do one of the following:
 - For tower models, open and remove the tower bezel ("Remove the tower bezel" on page 31).
 - For rack models, if installed, remove the security bezel ("Remove the security bezel (optional)" on page 31).
3. Power down the server (on page 30).
4. Remove all power:
 - a. Disconnect each power cord from the power source.
 - b. Disconnect each power cord from the server.
5. Do one of the following:

- For tower models, place the server on a flat, level surface with the access panel facing up.
 - For rack models, extend the server from the rack (on page 34).
6. Remove the access panel (on page 32).
 7. Remove the air baffle (on page 34).
 8. Remove the fan cage (on page 37).
 9. Remove the LFF drive cage blank ("Remove a drive cage blank" on page 39).
 10. Remove the divider between drive cages 1 and 3, and 2 and 4.

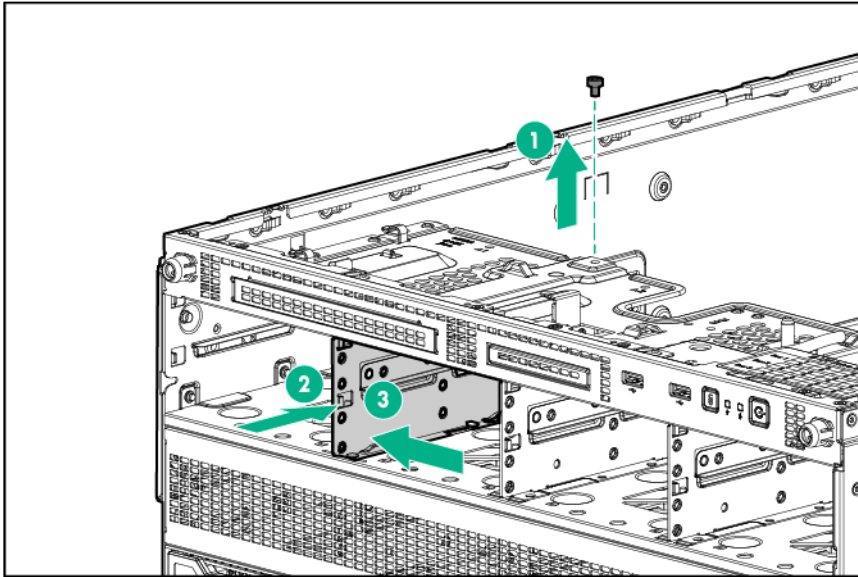

11. Install the media cage.

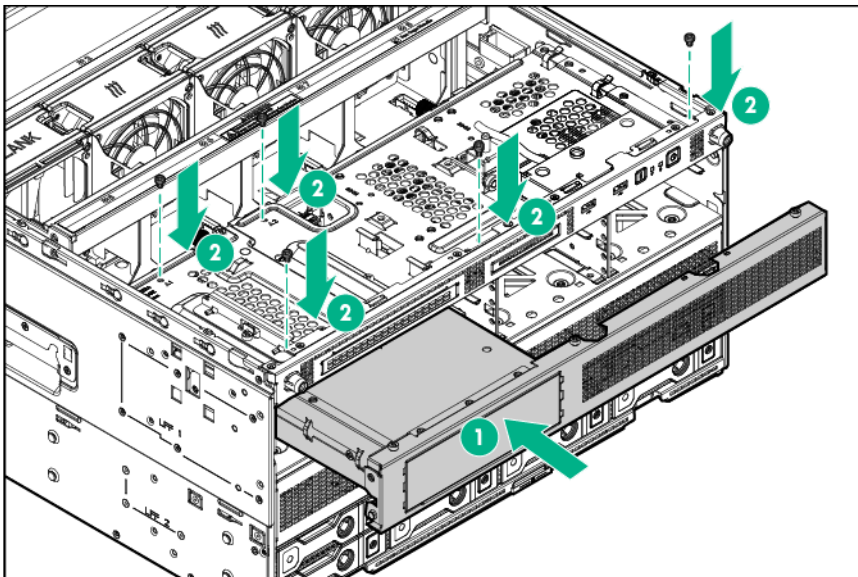

12. Install the media device.

13. Connect the LFF media power cable.

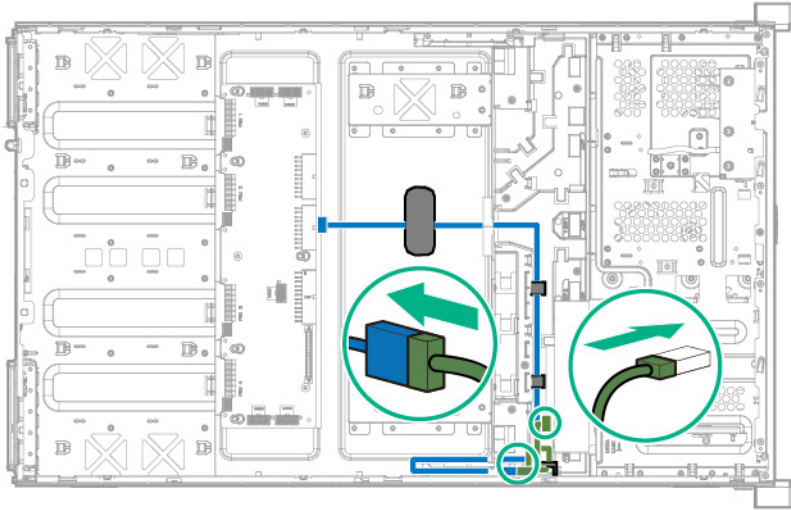

14. Connect the data cable to the media device.
Cable routing to connect a SATA device

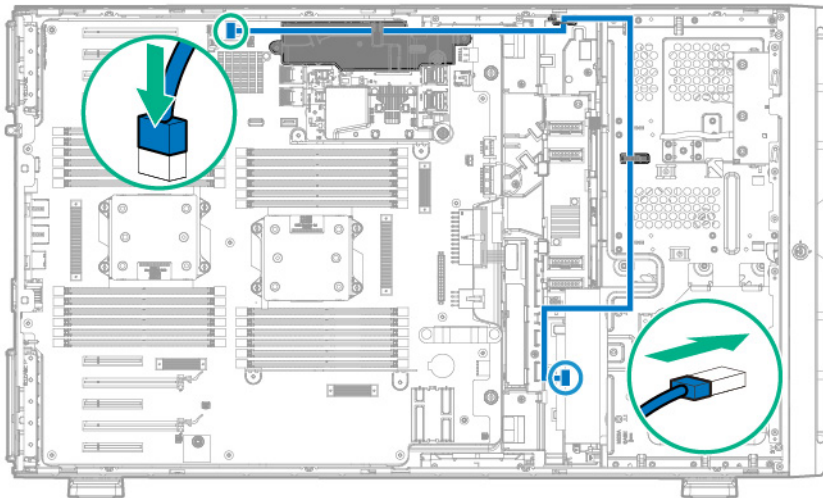

15. Install the fan cage (on page 38).
16. Install the air baffle (on page 35).
17. Install the access panel (on page 33).
18. Do one of the following:
 - o If the server is in a tower configuration, return the server to an upright position.
 - o If the server is in a rack configuration, slide the server into the rack.
19. Connect each power cord to the server.
20. Connect each power cord to the power source.
21. Power up the server ("Powering up the server" on page 30).
22. Do one of the following:
 - o For tower models, install the tower bezel (on page 31).

- For rack models, install the security bezel ("[Security bezel option](#)" on page 50).

GPU power cable option

For more information about product features, specifications, options, configurations, and compatibility, see the product QuickSpecs on the Hewlett Packard Enterprise website (<http://www.hpe.com/info/qs>).

To install a third 150W GPU, a third power supply must be installed. If more than two power supplies are needed, then the x4 Redundant power supply option ("[x4 Redundant Power Supply backplane option](#)" on page 125) must be installed.

The server supports up to four graphic cards, install graphic card options in PCIe slots 1, 3, 6, or 8.



IMPORTANT: If installing a graphic card for the first time, we highly recommend that you contact HPE Technology Services for assistance.

To install the component:

1. Back up all server data.
2. Do one of the following:
 - For tower models, open and remove the tower bezel ("[Remove the tower bezel](#)" on page 31).
 - For rack models, if installed, remove the security bezel ("[Remove the security bezel \(optional\)](#)" on page 31).
3. Power down the server (on page 30).
4. Remove all power:
 - a. Disconnect each power cord from the power source.
 - b. Disconnect each power cord from the server.
5. Do one of the following:
 - For tower models, place the server on a flat, level surface with the access panel facing up.
 - For rack models, extend the server from the rack (on page 34).
6. Remove the access panel (on page 32).
7. Remove the air baffle (on page 34).
8. Remove the fan cage (on page 37).
9. Disconnect all cables connected to the system board.
10. Remove the system board:
 - a. Loosen the two system board thumbscrews.

- b. Using the system board tray handles, slide the tray forward, and then remove the system board.

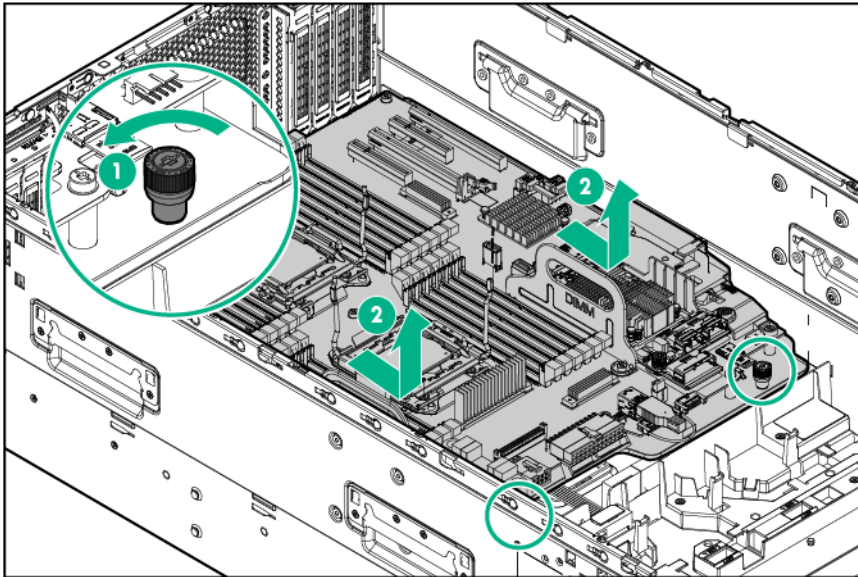

11. Connect the graphic card power cable to the nearest server graphic card power connector on the power supply backplane.

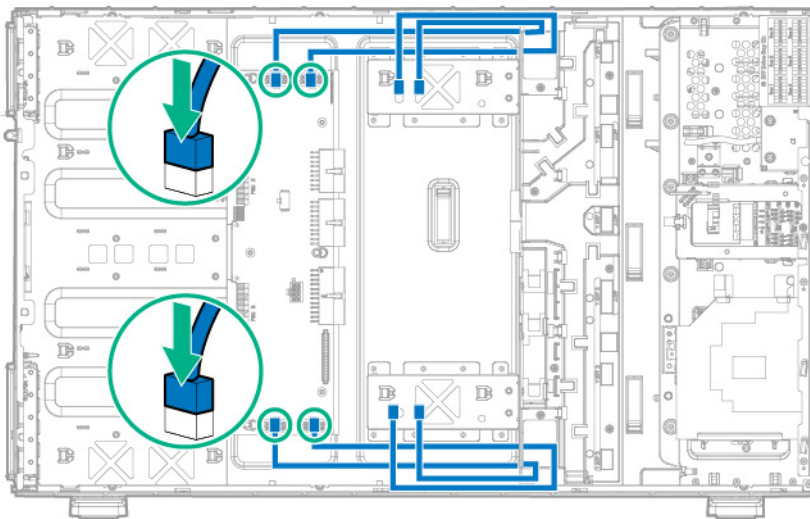

12. Install the system board assembly and tighten the two thumbscrews.

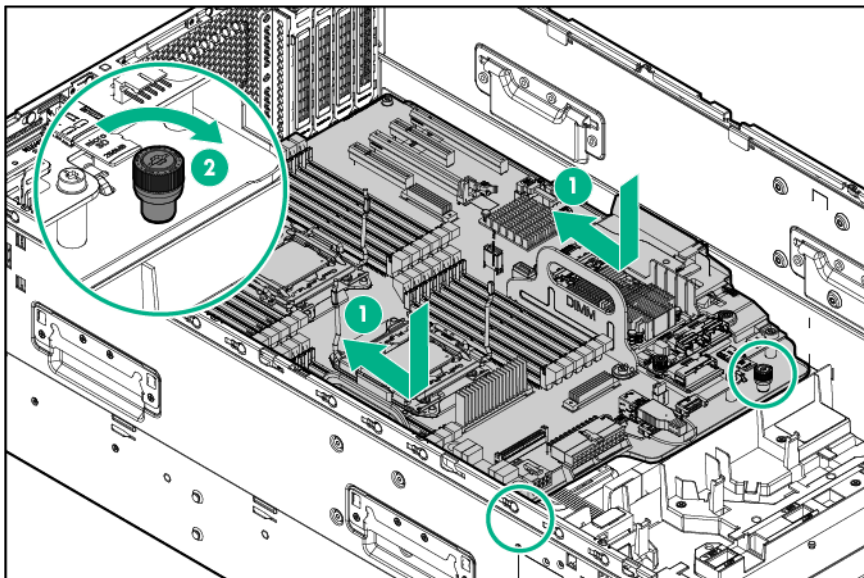

13. Open the PCI retainer latch.

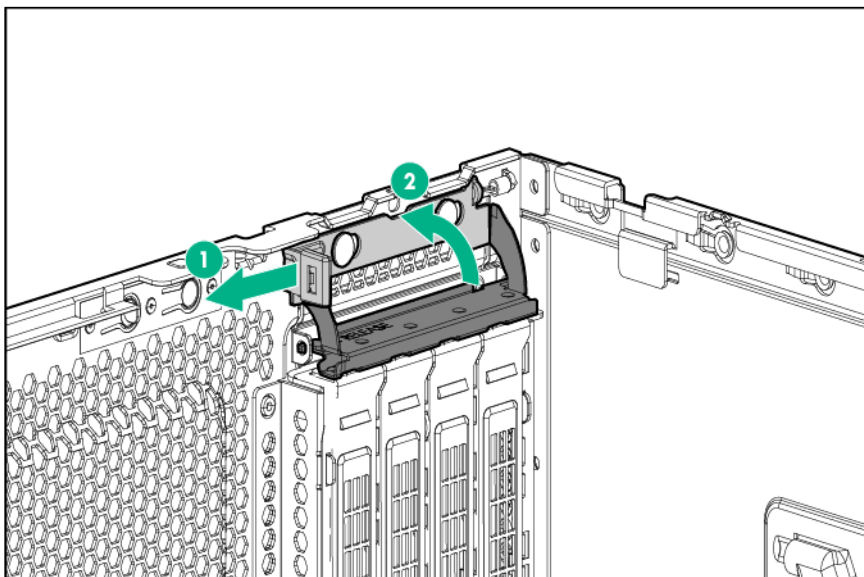

14. To install a single-width graphic card, remove one PCI blank. To install a double-width graphic card, remove two PCI blanks.

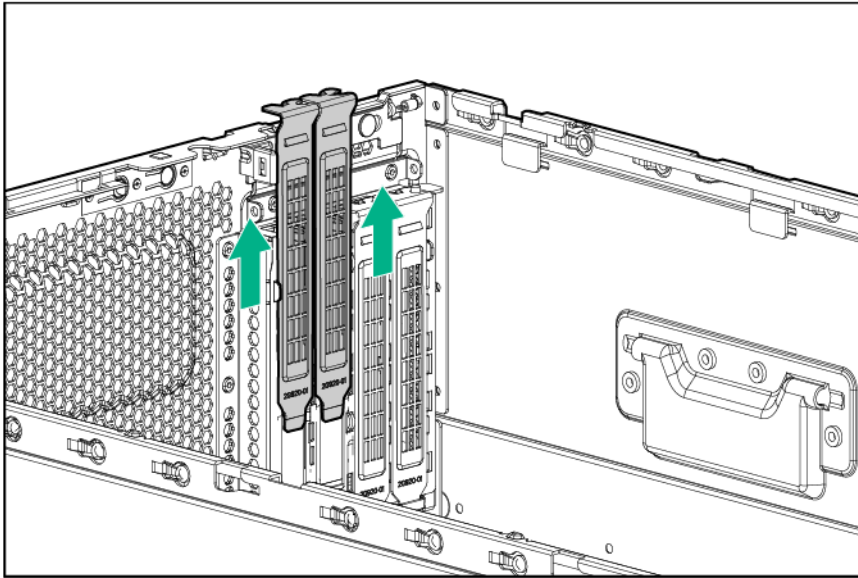

15. Connect the graphic card power cable to the graphic card.

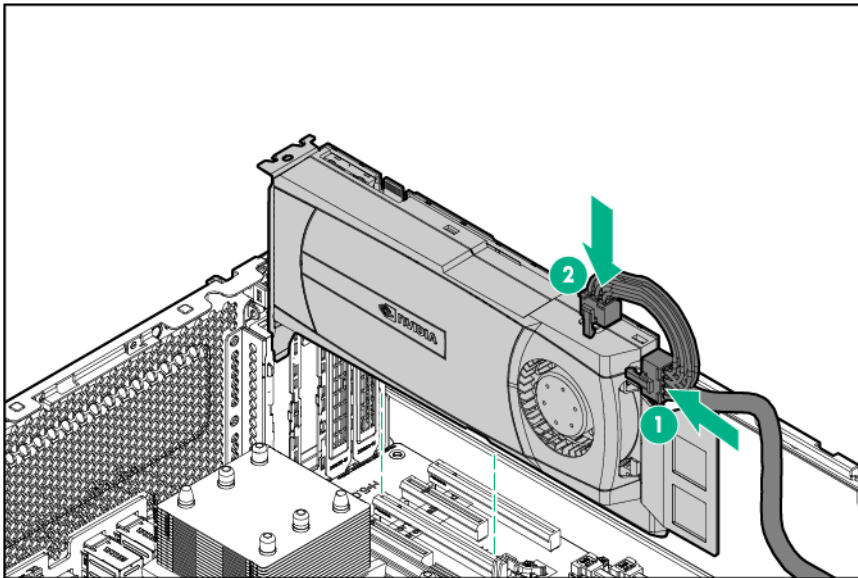

16. Install the graphic card in an x16 PCI expansion slot.

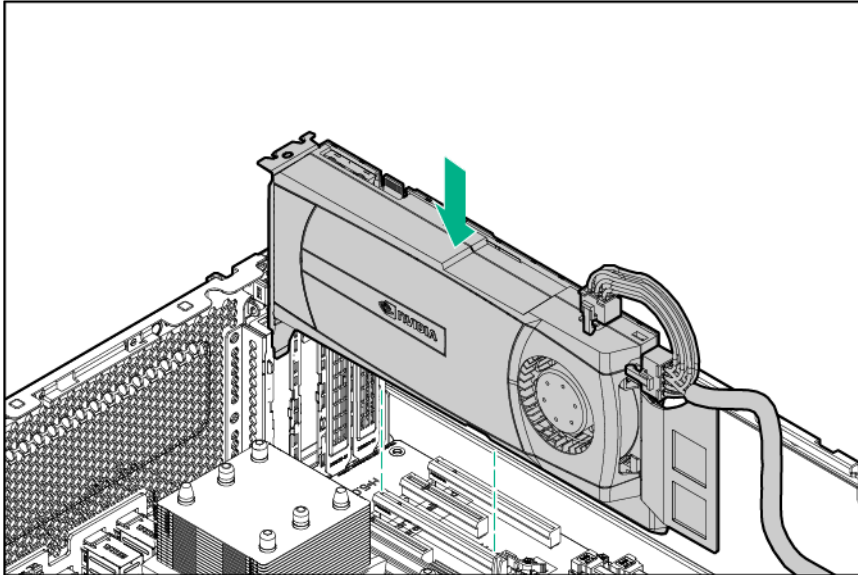

17. Close the PCIe retainer latch.

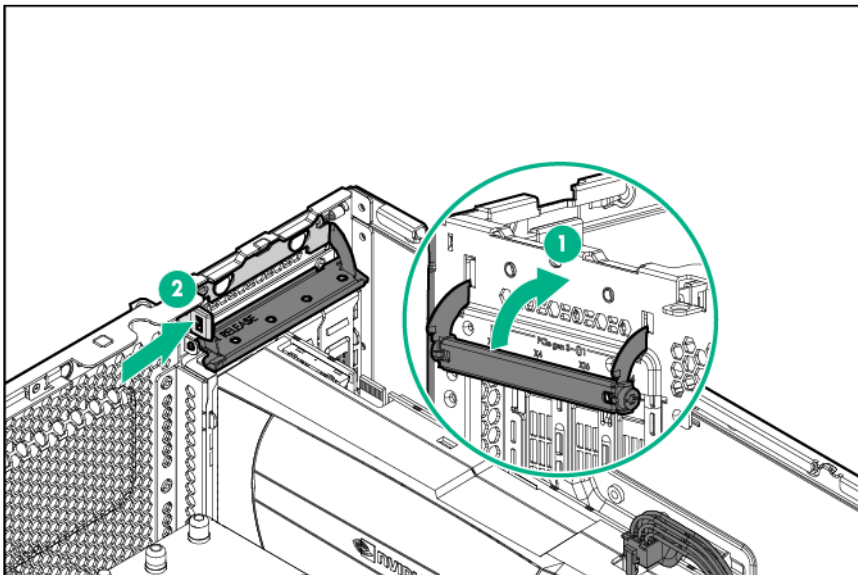

18. Install the fan cage (on page 38).
19. Install the air baffle (on page 35).
20. Install the access panel (on page 33).
21. Do one of the following:
- If the server is in a tower configuration, return the server to an upright position.
 - If the server is in a rack configuration, slide the server into the rack.
22. Connect each power cord to the server.
23. Connect each power cord to the power source.
24. Power up the server ("Powering up the server" on page 30).
25. Do one of the following:
- For tower models, install the tower bezel (on page 31).
 - For rack models, install the security bezel ("Security bezel option" on page 50).

Eight-bay SFF drive cage option

Install additional SFF drive cages option in this order: box 5, 4, 3, 2, and 1. For more information on drive and box numbering, see "Device numbering (on page 19)."

If more than 3 SFF drive cages (including an NVMe Express bay) are used, then the x4 Redundant power supply option ("x4 Redundant Power Supply backplane option" on page 125) must be installed.

To support an additional eight-bay SFF drive cage, an optional storage controller is required. To obtain the option, contact a Hewlett Packard Enterprise authorized reseller.

To install the component:

1. Back up all server data.
2. Do one of the following:
 - o For tower models, open and remove the tower bezel ("Remove the tower bezel" on page 31).
 - o For rack models, if installed, remove the security bezel ("Remove the security bezel (optional)" on page 31).
3. Power down the server (on page 30).
4. Remove all power:
 - a. Disconnect each power cord from the power source.
 - b. Disconnect each power cord from the server.
5. Do one of the following:
 - o For tower models, place the server on a flat, level surface with the access panel facing up.
 - o For rack models, extend the server from the rack (on page 34).
6. Remove the access panel (on page 32).
7. Remove the air baffle (on page 34).
8. Remove the fan cage (on page 37).
9. Remove the drive cage blank ("Remove a drive cage blank" on page 39).
10. Install the SFF drive cage.

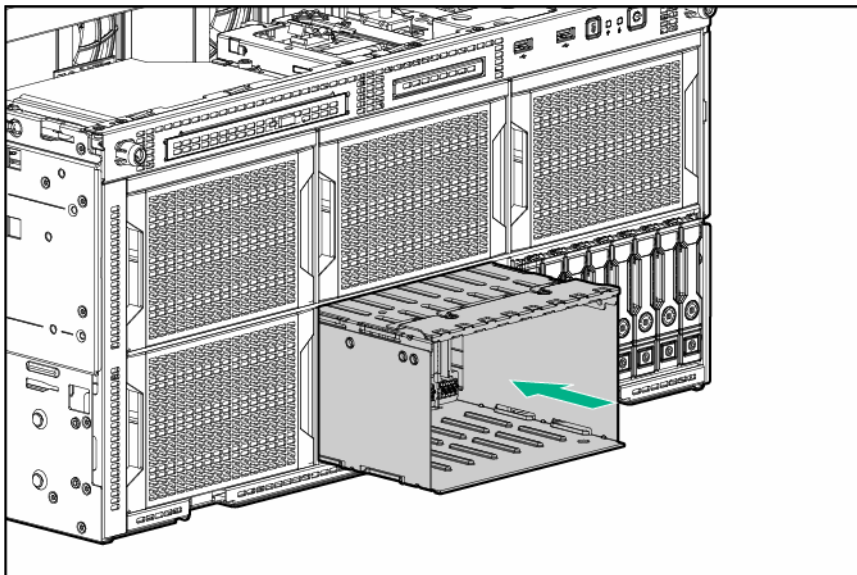

11. Using the two T-15 screws, secure the rear side of the drive cage.

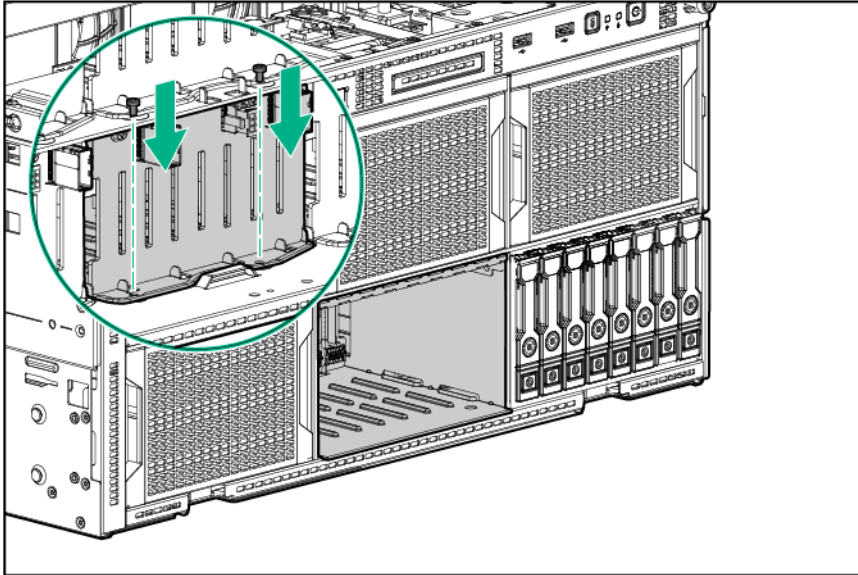

12. Connect the Mini-SAS cable from a storage controller to the drive backplane:
o Cable routing if the storage controller is installed in PCIe slot 1 to 4.

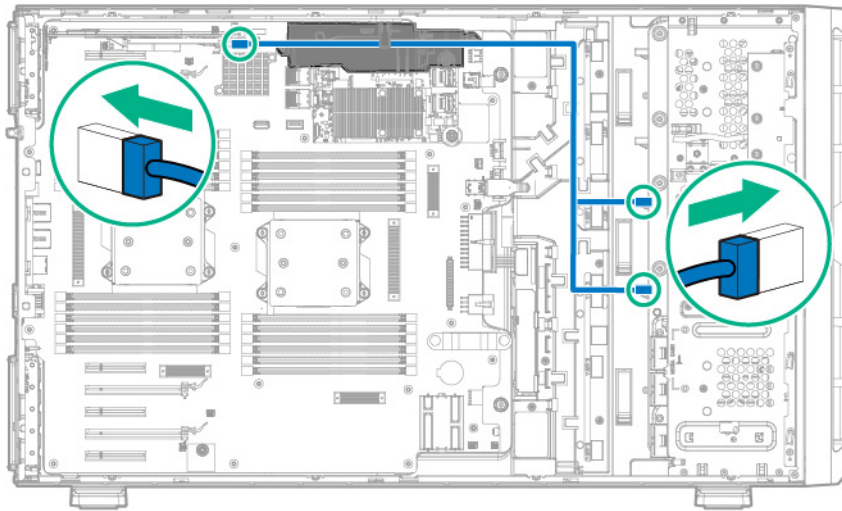

- o Cable routing if second processor is installed and the storage controller is installed in slot 6 to 9.

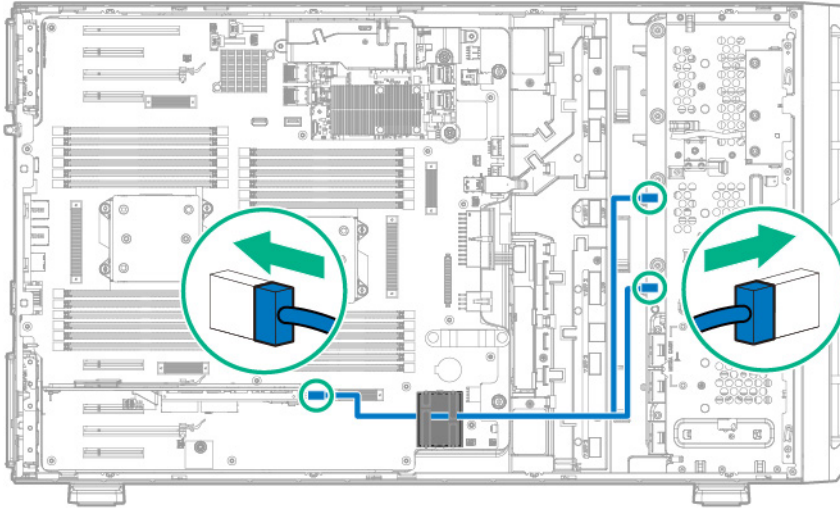

13. Connect the power cable to the drive backplane.

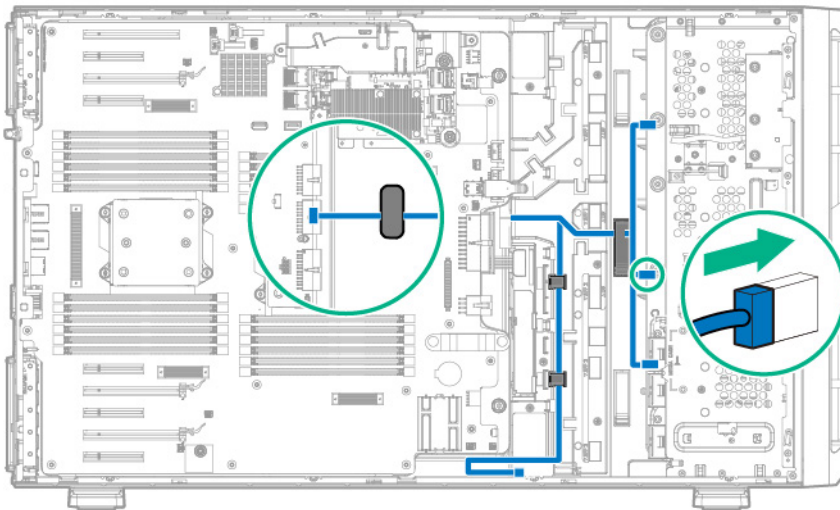

14. Install the drives into the drive cage.
15. Populate any unused drive bays with a drive blank.
16. Install the fan cage (on page 38).
17. Install the air baffle (on page 35).
18. Install the access panel (on page 33).
19. Do one of the following:
 - o If the server is in a tower configuration, return the server to an upright position.
 - o If the server is in a rack configuration, slide the server into the rack.
20. Connect each power cord to the server.
21. Connect each power cord to the power source.
22. Power up the server ("Powering up the server" on page 30).
23. Do one of the following:

- For tower models, install the tower bezel (on page 31).
- For rack models, install the security bezel ("[Security bezel option](#)" on page 50).

Eight-bay LFF drive backplane option

The server ships with a drive backplane and cables for data and power installed for box 3. Install a second optional backplane in box 2 and then a third optional backplane in box 1.

To install an additional eight-bay LFF drive cage, an optional storage controller is required. To obtain the option, contact a Hewlett Packard Enterprise authorized reseller.

For more information on drive and box numbering, see "[Device numbering](#) (on page 19)."

To install the component:

1. Back up all server data.
2. Do one of the following:
 - For tower models, open and remove the tower bezel ("[Remove the tower bezel](#)" on page 31).
 - For rack models, if installed, remove the security bezel ("[Remove the security bezel \(optional\)](#)" on page 31).
3. Power down the server (on page 30).
4. Remove all power:
 - a. Disconnect each power cord from the power source.
 - b. Disconnect each power cord from the server.
5. Do one of the following:
 - For tower models, place the server on a flat, level surface with the access panel facing up.
 - For rack models, extend the server from the rack (on page 34).
6. Remove the access panel (on page 32).
7. Remove the air baffle (on page 34).
8. Remove the fan cage (on page 37).
9. Attach the hot-plug drive backplane to the drive cage, and then tighten the thumbscrews.

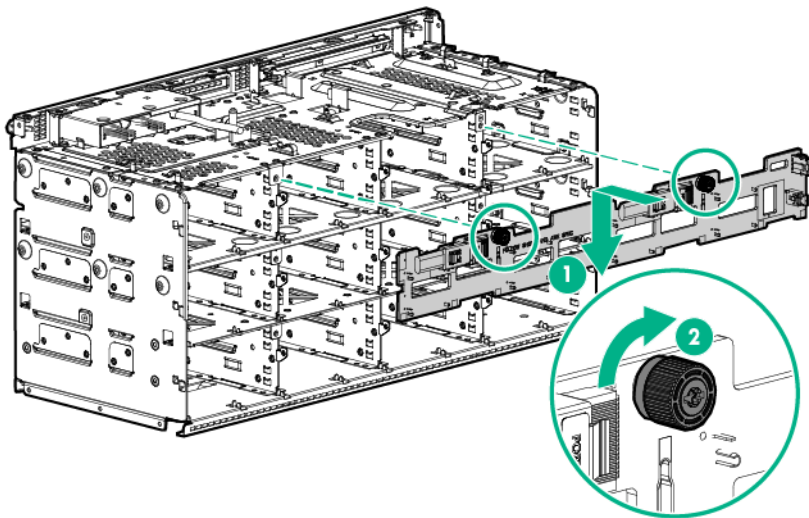

10. Connect the Mini-SAS cable from the storage controller to the drive backplane.

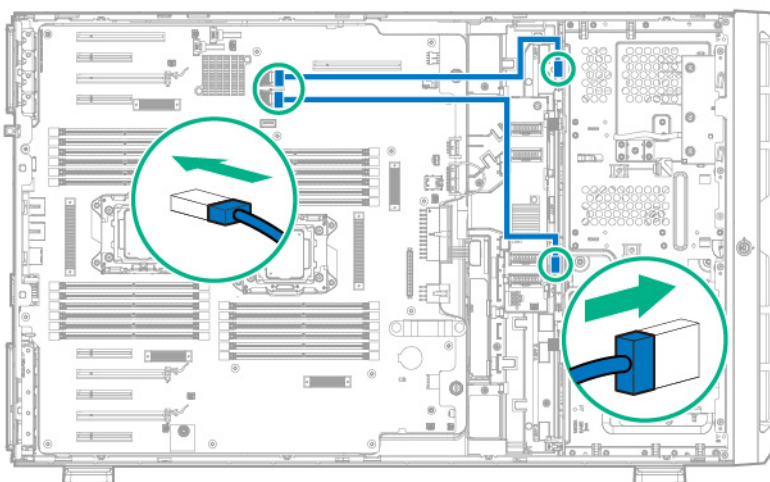

11. Connect either the box 1 or box 2 power cable to the new backplane.

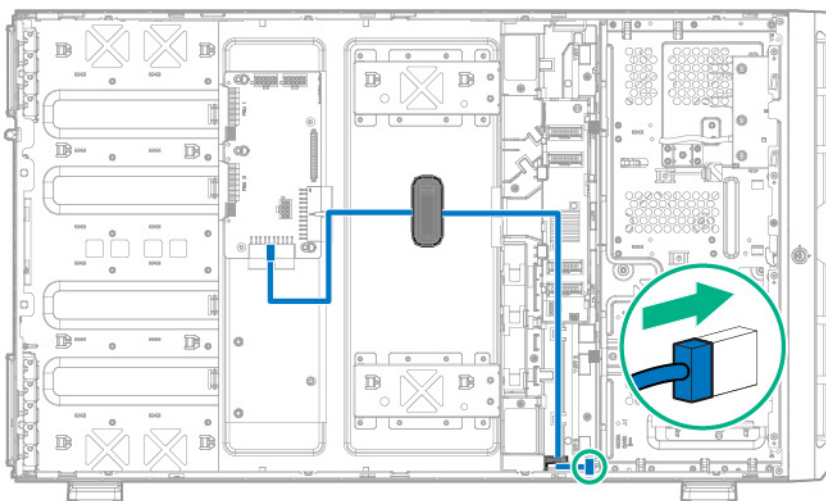

12. Install drives into the drive cage.
13. Populate any unused drive bays with a drive blank.
14. Install the fan cage (on page 38).
15. Install the air baffle (on page 35).
16. Install the access panel (on page 33).
17. Do one of the following:
 - o If the server is in a tower configuration, return the server to an upright position.
 - o If the server is in a rack configuration, slide the server into the rack.
18. Connect each power cord to the server.
19. Connect each power cord to the power source.
20. Power up the server ("[Powering up the server](#)" on page 30).
21. Do one of the following:

- For tower models, install the tower bezel (on page 31).
- For rack models, install the security bezel ("[Security bezel option](#)" on page 50).

M.2 SSD enablement board option

The M.2 enablement board is only supported in PCIe slot 1.

Installing an M.2 SSD enablement board

1. Back up all server data.
2. Do one of the following:
 - For tower models, open and remove the tower bezel ("[Remove the tower bezel](#)" on page 31).
 - For rack models, if installed, remove the security bezel ("[Remove the security bezel \(optional\)](#)" on page 31).
3. Power down the server (on page 30).
4. Remove all power:
 - a. Disconnect each power cord from the power source.
 - b. Disconnect each power cord from the server.
5. Do one of the following:
 - For tower models, place the server on a flat, level surface with the access panel facing up.
 - For rack models, extend the server from the rack (on page 34).
6. Install the M.2 SSD enablement board into PCIe slot 1.

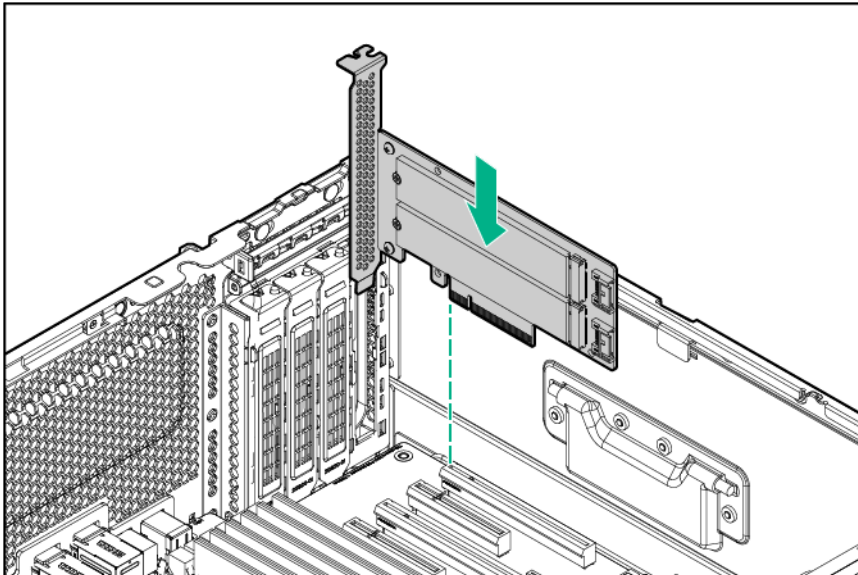

7. Connect and route the SATA cables from the M.2 SSD enablement board to the system board.

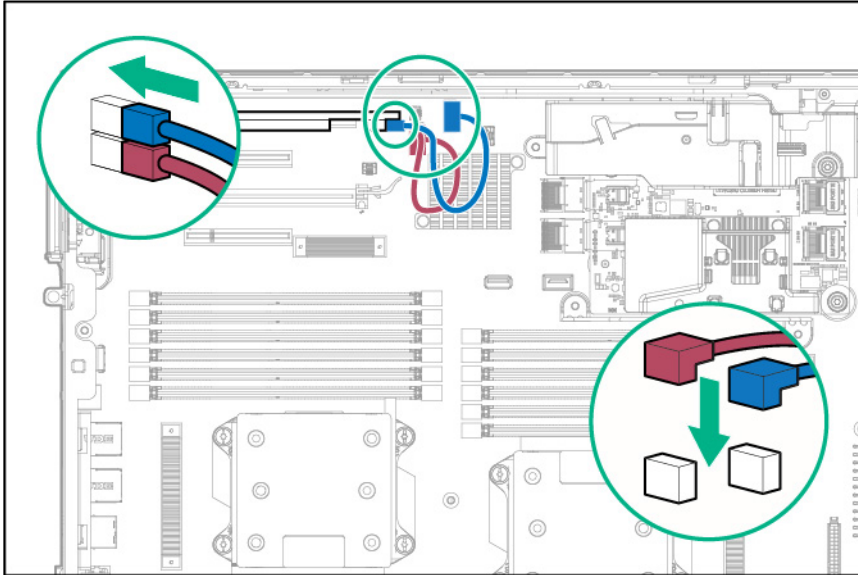

8. Install the air baffle (on page 35).
9. Install the access panel (on page 33).
10. Do one of the following:
 - o If the server is in a tower configuration, return the server to an upright position.
 - o If the server is in a rack configuration, slide the server into the rack.
11. Connect each power cord to the server.
12. Connect each power cord to the power source.
13. Power up the server ("[Powering up the server](#)" on page 30).
14. Do one of the following:
 - o For tower models, install the tower bezel (on page 31).
 - o For rack models, install the security bezel ("[Security bezel option](#)" on page 50).

Installing an SSD module

1. Back up all server data.
2. Do one of the following:
 - o For tower models, open and remove the tower bezel ("[Remove the tower bezel](#)" on page 31).
 - o For rack models, if installed, remove the security bezel ("[Remove the security bezel \(optional\)](#)" on page 31).
3. Power down the server (on page 30).
4. Remove all power:
 - a. Disconnect each power cord from the power source.
 - b. Disconnect each power cord from the server.
5. Do one of the following:
 - o For tower models, place the server on a flat, level surface with the access panel facing up.
 - o For rack models, extend the server from the rack (on page 34).
6. Remove the access panel (on page 32).
7. Remove the air baffle (on page 34).



IMPORTANT: For management and monitoring of the SSD modules, use the HPE Smart Storage Administrator (<http://www.hpe.com/servers/ssa>).

8. Install the SSD module on the M.2 SSD enablement board.

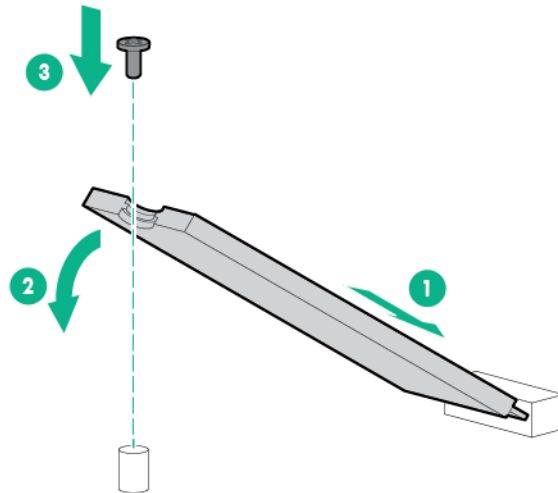

9. Install the M.2 SSD Enablement Board in slot one of the PCIe riser cage ("Installing an M.2 SSD enablement board" on page 121).
10. Install the air baffle (on page 35).
11. Install the access panel (on page 33).
12. Do one of the following:
 - o If the server is in a tower configuration, return the server to an upright position.
 - o If the server is in a rack configuration, slide the server into the rack.
13. Connect each power cord to the server.
14. Connect each power cord to the power source.
15. Power up the server ("Powering up the server" on page 30).
16. Do one of the following:
 - o For tower models, install the tower bezel (on page 31).
 - o For rack models, install the security bezel ("Security bezel option" on page 50).

Dual 8Gb microSD Enterprise Midline USB device

This server supports the installation of the Dual 8Gb microSD Enterprise Midline USB device on the server internal USB connector.

This USB storage device contains a dual-SD card module that supports up to two SD, SDHC, or SDXC storage cards providing data redundancy through a mirrored RAID-1 configuration. This USB storage device connects to an internal USB connector and is configured upon boot.

To locate the internal USB connector, see "System board components (on page 15)." For more information, see the Dual 8Gb microSD EM USB storage device documentation on the Hewlett Packard Enterprise website (<http://www.hpe.com/support/8GBDualMicrosd ug en>).

Power supply options

Hot-plug power supply module

CAUTION: All power supplies installed in the server must have the same output power capacity. Verify that all power supplies have the same part number and label color. The system becomes unstable and may shut down when it detects mismatched power supplies.

CAUTION: To prevent improper cooling and thermal damage, do not operate the server unless all bays are populated with either a component or a blank.

To install the component:

1. Access the product rear panel.
2. Remove the blank.

WARNING: To reduce the risk of personal injury from hot surfaces, allow the power supply or power supply blank to cool before touching it.

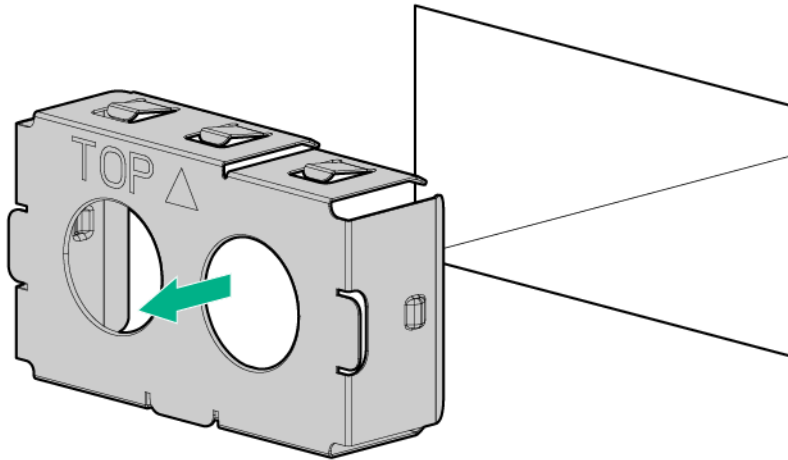

3. Insert the power supply into the power supply bay until it clicks into place.

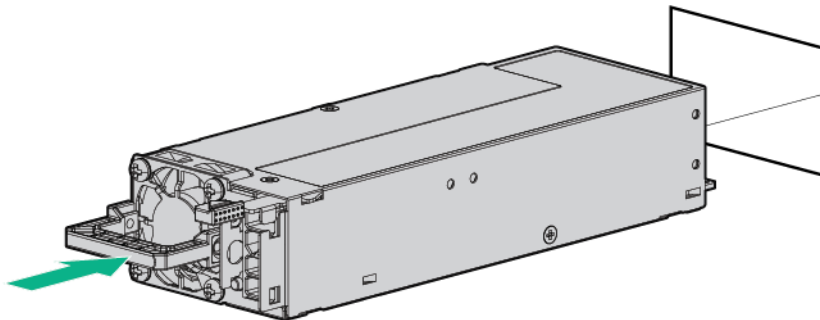

4. Connect the power cord to the power supply.

5. Route the power cord. Use best practices when routing power cords and other cables. A cable management arm is available to help with routing. To obtain a cable management arm, contact a Hewlett Packard Enterprise authorized reseller.
6. Connect the power cord to the AC power source.

x4 Redundant Power Supply backplane option

The x4 Redundant Power Supply backplane option must be installed when more than 3 SFF drive cages (including an NVMe Express bay) are used.



WARNING: When the x4 RPS kit is installed, at least three power supply modules must be installed in the server.

To install the component:

1. Back up all server data.
2. Do one of the following:
 - o For tower models, open and remove the tower bezel ("[Remove the tower bezel](#)" on page 31).
 - o For rack models, if installed, remove the security bezel ("[Remove the security bezel \(optional\)](#)" on page 31).
3. Power down the server (on page 30).
4. Remove all power:
 - a. Disconnect each power cord from the power source.
 - b. Disconnect each power cord from the server.
5. Do one of the following:
 - o For tower models, place the server on a flat, level surface with the access panel facing up.
 - o For rack models, extend the server from the rack (on page 34).
6. Remove the access panel (on page 32).
7. Remove the air baffle (on page 34).
8. Remove the fan cage (on page 37).
9. Disconnect all cables connected to the expansion boards and remove all expansion boards.
10. Disconnect all cables from the system board.
11. Remove the system board:
 - a. Loosen the two system board thumbscrews.

- b. Using the system board tray handles, slide the tray forward, and then remove the system board.

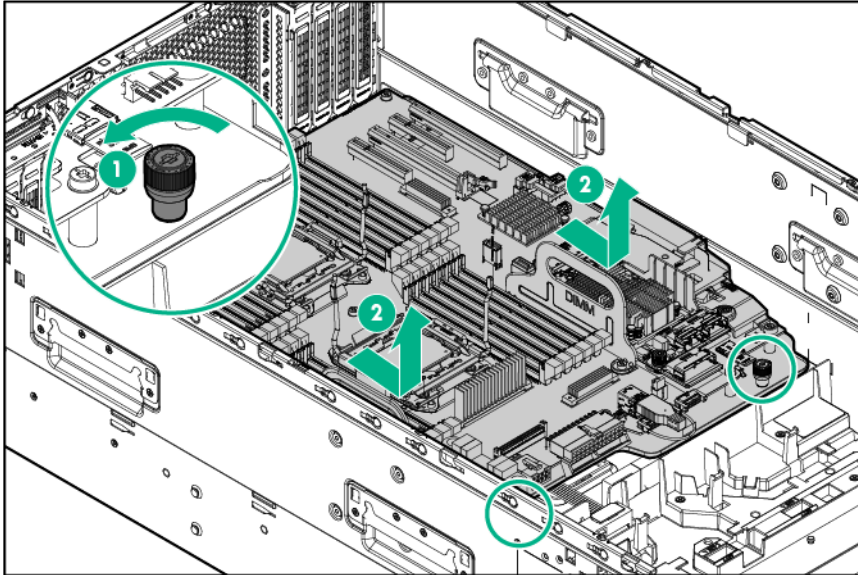

12. Remove all power supplies.
13. Remove the two bay power supply backplane:
- Disconnect all cables connected to the power supply backplane. Retain all the cables for reconnecting them to the x4 RPS backplane.
 - Remove the two screws securing the backplane to the chassis.
 - Slide the backplane towards the rear of the server, and then lift and remove the backplane.

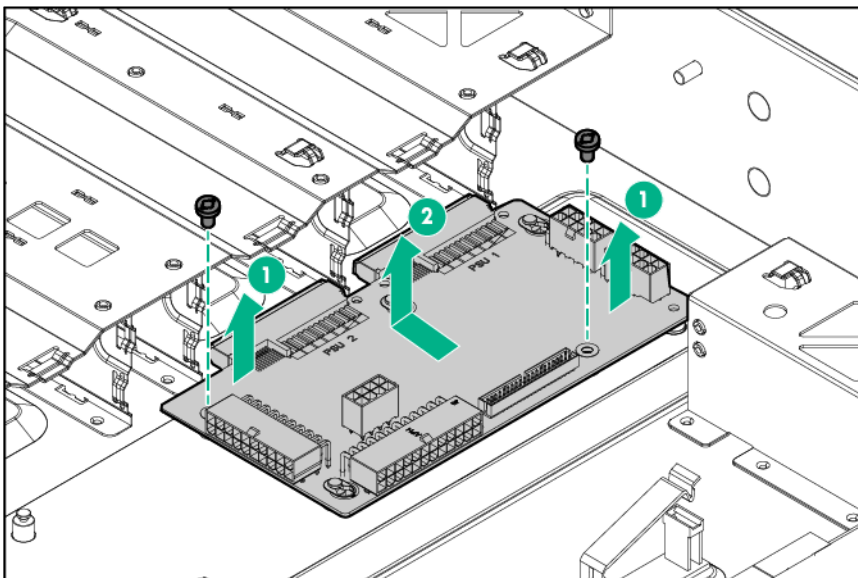

14. Install the four-bay power supply backplane board:
- Align the backplane to the pins on the chassis.
 - Slide the backplane towards the front of the server.

c. Tighten the three screws on the backplane.

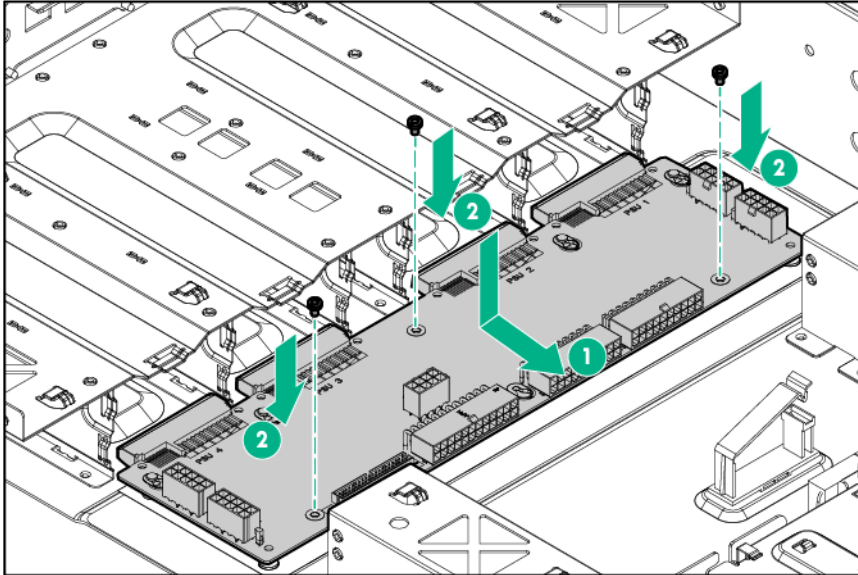

15. Connect all cables to the x4 RPS backplane board.

16. Route the x4 RPS backplane cables.

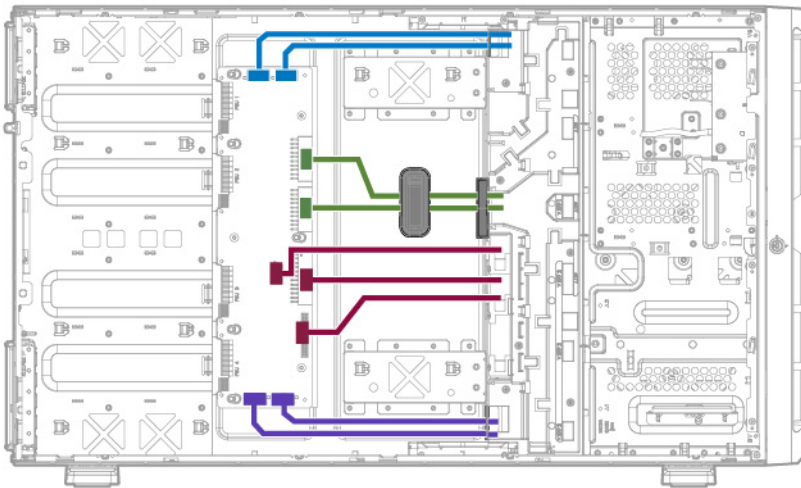

17. Install the system board.

18. Connect all the cables disconnected from the system board.

19. Install the expansion boards.

20. Install the fan cage.

21. Remove the cover over power supply slots 3 and 4.

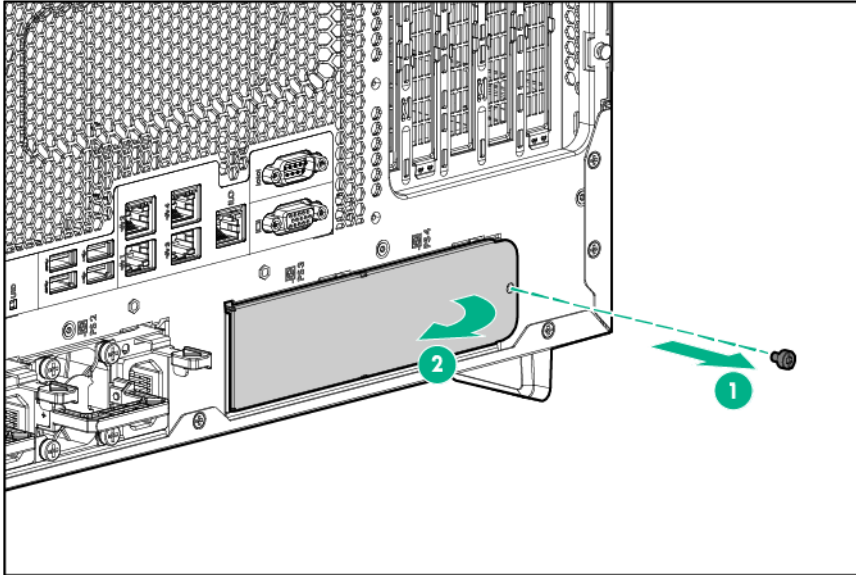

22. Install all power supplies.
Install a power supply blank into any unpopulated power supply bays.

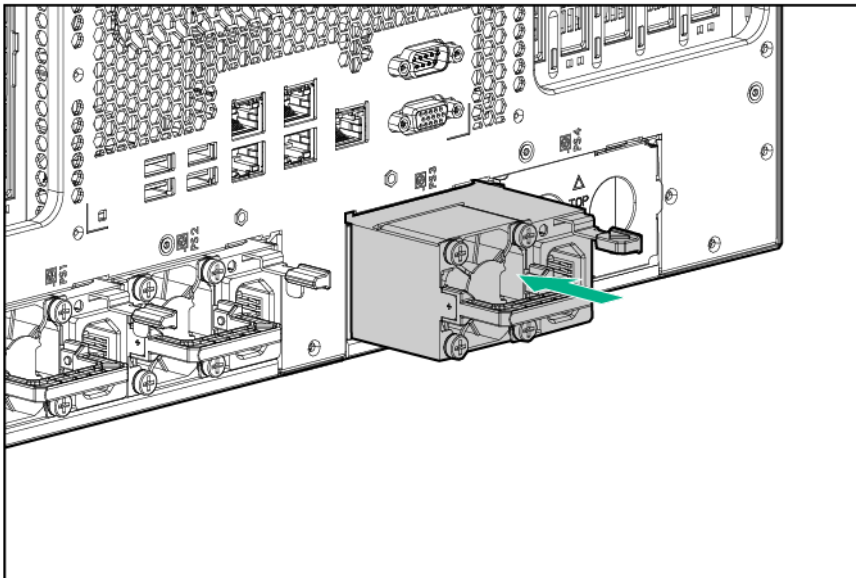

23. Install the fan cage (on page [38](#)).
24. Install the air baffle (on page [35](#)).
25. Install the access panel (on page [33](#)).
26. Do one of the following:
- If the server is in a tower configuration, return the server to an upright position.
 - If the server is in a rack configuration, slide the server into the rack.
27. Connect each power cord to the server.
28. Connect each power cord to the power source.
29. Power up the server ("[Powering up the server](#)" on page [30](#)).
30. Do one of the following:
- For tower models, install the tower bezel (on page [31](#)).

- For rack models, install the security bezel ("[Security bezel option](#)" on page 50).

Power supply modes

Power supply modules configuration

- When the x4 RPS kit is installed and 3+1 power supply redundancy is selected, for minimum non-redundant configuration at least three power supply modules must be installed in the server. For full redundancy four power supply modules are required.
- When the x4 RPS kit is installed and 2+2 power supply redundancy is selected, for minimum non-redundant configuration at least two power supply modules must be installed in the server. For full redundancy four power supply modules are required.

If more than two GPU cards are installed then the X4 RPS Enablement Kit must be installed to have enough GPU power connectors.

If more than three SFF hard drive cages are installed, then the X4 RPS Enablement Kit must be installed in order to have enough drive power connectors.

The x4 Redundant Power Supply Enablement (RPS) Kit only supports the HPE 800 W and HPE 1400 W Flex Slot Platinum hot-plug power supplies.

Selecting the power supply mode

When the x4 Redundant Power Supply Enablement Kit is installed, system power supply capacity increases from 2 to 4 PSUs, and the system can be configured for 1 or 2 different power sources. In the default 3+1 mode one PSU is redundant. Select 2+2 power supply mode to support power supplied from two different power sources.

System ROM must be upgraded to P92 v2.30 for power supply mode selection to be available.

To select a power supply mode:

1. Reboot the server.
The server restarts and the POST screen appears.
2. Press **F9**.
The system utilities screen appears.
3. Select **System Configuration** → **BIOS/Platform Configuration (RBSU)** → **Advanced Options** → **Redundant Power Supply Mode**, and then press **Enter**.
4. Select **Configured for 3+1 Redundancy** or **Configured for 2+2 Redundancy** and then press **Enter**.
5. Press **F10** to save the selection.
6. Press **Y** to save the changes.
7. Select **Exit** and resume system boot, and press **Enter**. The server continues the normal boot process.

System health and power redundancy

Good power supplies are detected at boot time and system power redundancy is set at boot time.

Selected power supply mode	3+1 Power configuration	2+2 Power configuration
4 PSUs detected at POST	Health = Green (Normal) Redundant configuration	Health = Green (Normal) Redundant configuration
3 PSUs detected at POST	Health = Green (Normal) Non-Redundant configuration	Health = Green (Normal) Redundant configuration

Selected power supply mode	3+1 Power configuration	2+2 Power configuration
2 PSUs detected at POST	Health = Red (critical) System cannot power on	Health = Green (Normal) Redundant configuration
1 PSUs detected at POST	Health = Red (critical) System cannot power on	Health = Red (critical) System cannot power on

System health and behavior if power supplies fail during server operation

- 3+1 power supply mode

Detected PSUs at POST	4 PSUs detected at POST	3 PSUs detected at POST
no PSU failure	Health = Green (Normal)	Health = Green (Normal)
1 PSU failure	Health = Amber Degraded operation	Health = Red System gracefully shuts down
2 PSU failure	Health = Red System gracefully shuts down	—

- 2+2 power supply mode

Detected PSUs at POST	4 PSUs detected at POST	3 PSUs detected at POST	2 PSUs detected at POST
no PSU failure	Health = Green (Normal)	Health = Green (Normal)	Health = Green (Normal)
1 PSU failure	Health = Amber Degraded operation	Health = Amber Degraded operation	Health = Red System gracefully shuts down
2 PSU failure	Health = Amber Degraded operation	Health = Red System gracefully shuts down	—
3 PSU failure	Health = Red System gracefully shuts down	—	—

HPE Trusted Platform Module option

For more information about product features, specifications, options, configurations, and compatibility, see the product QuickSpecs on the Hewlett Packard Enterprise website (<http://www.hpe.com/info/qs>).

Use these instructions to install and enable a TPM on a supported server. This procedure includes three sections:

1. Installing the Trusted Platform Module board.
2. Retaining the recovery key/password (on page 133).
3. Enabling the Trusted Platform Module (on page 133).

Enabling the TPM requires accessing RBSU. For more information about RBSU, see the Hewlett Packard Enterprise website. (<http://www.hpe.com/support/rbsu>)

TPM installation requires the use of drive encryption technology, such as the Microsoft Windows BitLocker Drive Encryption feature. For more information on BitLocker, see the Microsoft website (<http://www.microsoft.com>).



CAUTION: Always observe the guidelines in this document. Failure to follow these guidelines can cause hardware damage or halt data access.

When installing or replacing a TPM, observe the following guidelines:

- Do not remove an installed TPM. Once installed, the TPM becomes a permanent part of the system board.
- When installing or replacing hardware, Hewlett Packard Enterprise service providers cannot enable the TPM or the encryption technology. For security reasons, only the customer can enable these features.
- When returning a system board for service replacement, do not remove the TPM from the system board. When requested, Hewlett Packard Enterprise Service provides a TPM with the spare system board.
- Any attempt to remove an installed TPM from the system board breaks or disfigures the TPM security rivet. Upon locating a broken or disfigured rivet on an installed TPM, administrators should consider the system compromised and take appropriate measures to ensure the integrity of the system data.
- When using BitLocker, always retain the recovery key/password. The recovery key/password is required to enter Recovery Mode after BitLocker detects a possible compromise of system integrity.
- Hewlett Packard Enterprise is not liable for blocked data access caused by improper TPM use. For operating instructions, see the encryption technology feature documentation provided by the operating system.

Installing the Trusted Platform Module and security rivet

△ CAUTION: Any attempt to remove an installed TPM from the system board breaks or disfigures the TPM security rivet. Upon locating a broken or disfigured rivet on an installed TPM, administrators should consider the system compromised and take appropriate measures to ensure the integrity of the system data.

To install the component:

1. Do one of the following:
 - For tower models, open and remove the tower bezel ("[Remove the tower bezel](#)" on page 31).
 - For rack models, if installed, remove the security bezel ("[Remove the security bezel \(optional\)](#)" on page 31).
2. Power down the server (on page 30).
3. Remove all power:
 - a. Disconnect each power cord from the power source.
 - b. Disconnect each power cord from the server.
4. Do one of the following:
 - For tower models, place the server on a flat, level surface with the access panel facing up.
 - For rack models, extend the server from the rack (on page 34).
5. Remove the access panel (on page 32).
6. Remove the air baffle (on page 34).

△ CAUTION: Any attempt to remove an installed TPM from the system board breaks or disfigures the TPM security rivet. Upon locating a broken or disfigured rivet on an installed TPM, administrators should consider the system compromised and take appropriate measures to ensure the integrity of the system data.

7. Install the TPM board. Press down on the connector to seat the board ("[System board components](#)" on page [15](#)).

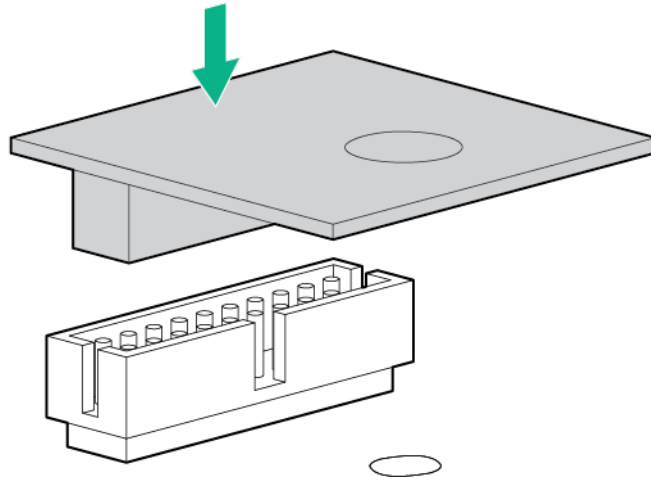

8. Install the TPM security rivet by pressing the rivet firmly into the system board.

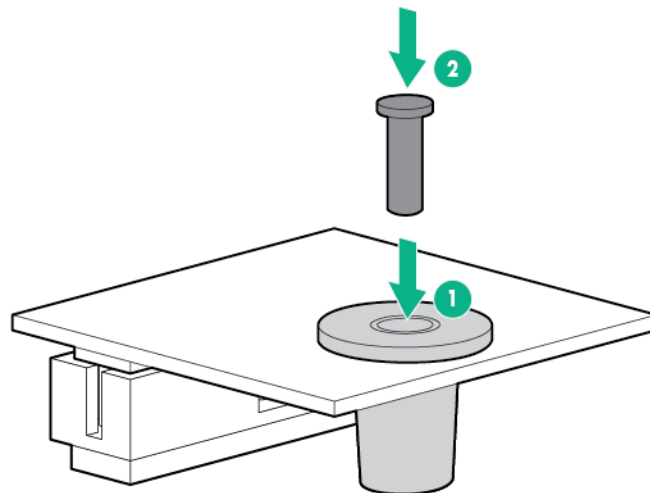

9. Install the air baffle (on page [35](#)).
10. Install the access panel (on page [33](#)).
11. Do one of the following:
 - If the server is in a tower configuration, return the server to an upright position.
 - If the server is in a rack configuration, slide the server into the rack.
12. Connect each power cord to the server.
13. Connect each power cord to the power source.
14. Power up the server ("[Powering up the server](#)" on page [30](#)).
15. Do one of the following:
 - For tower models, install the tower bezel (on page [31](#)).
 - For rack models, install the security bezel ("[Security bezel option](#)" on page [50](#)).

Retaining the recovery key/password

The recovery key/password is generated during BitLocker setup, and can be saved and printed after BitLocker is enabled. When using BitLocker, always retain the recovery key/password. The recovery key/password is required to enter Recovery Mode after BitLocker detects a possible compromise of system integrity.

To help ensure maximum security, observe the following guidelines when retaining the recovery key/password:

- Always store the recovery key/password in multiple locations.
- Always store copies of the recovery key/password away from the server.
- Do not save the recovery key/password on the encrypted hard drive.

Enabling the Trusted Platform Module

1. When prompted during the start-up sequence, access RBSU by pressing the **F9** key.
2. From the Main Menu, select **Server Security**.
3. From the Server Security Menu, select **Trusted Platform Module**.
4. From the Trusted Platform Module Menu, select **TPM Functionality**.
5. Select **Enable**, and then press the **Enter** key to modify the TPM Functionality setting.
6. Press the **Esc** key to exit the current menu, or press the **F10** key to exit RBSU.
7. Reboot the server.
8. Enable the TPM in the OS. For OS-specific instructions, see the OS documentation.



CAUTION: When a TPM is installed and enabled on the server, data access is locked if you fail to follow the proper procedures for updating the system or option firmware, replacing the system board, replacing a hard drive, or modifying OS application TPM settings.

For more information on firmware updates and hardware procedures, see the *HP Trusted Platform Module Best Practices White Paper* on the Hewlett Packard Enterprise website (<http://www.hpe.com/support/hpesc>).

For more information on adjusting TPM usage in BitLocker™, see the Microsoft website (<http://technet.microsoft.com/en-us/library/cc732774.aspx>).

Cabling

Cabling overview

This section provides guidelines that help you make informed decisions about cabling the server and hardware options to optimize performance.

For information on cabling peripheral components, refer to the white paper on high-density deployment at the Hewlett Packard Enterprise website (<http://www.hpe.com/info/servers>).



CAUTION: When routing cables, always be sure that the cables are not in a position where they can be pinched or crimped.

Media device data cabling

- SFF media cage data cabling

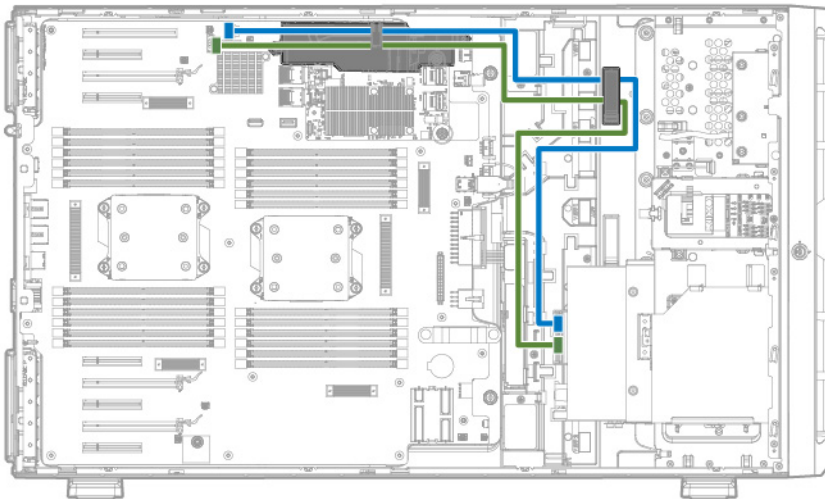

- LFF media cage data cabling

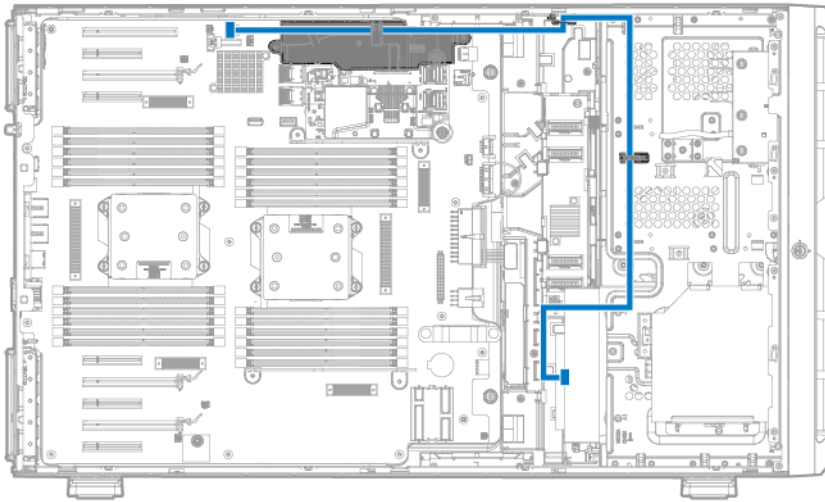

Optical device cabling

- LFF configuration

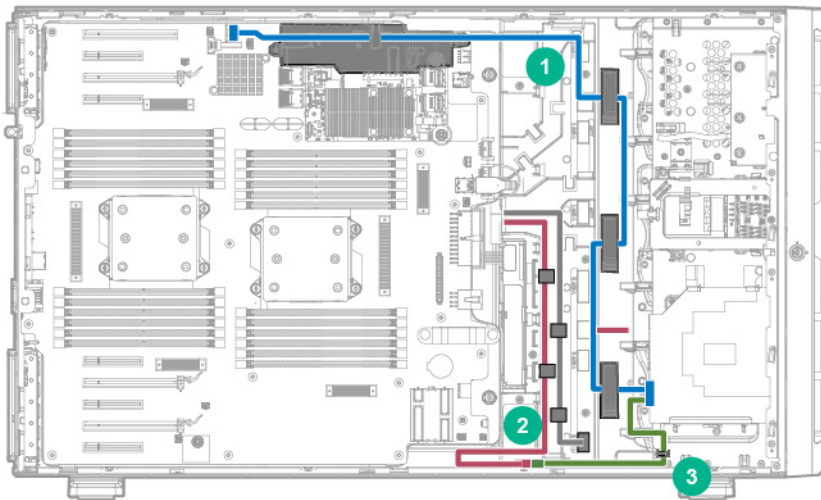

Item	Description
1	ODD signal cable to SATA port 5
2	Power supply backplane cable
3	ODD power cable

- SFF configuration

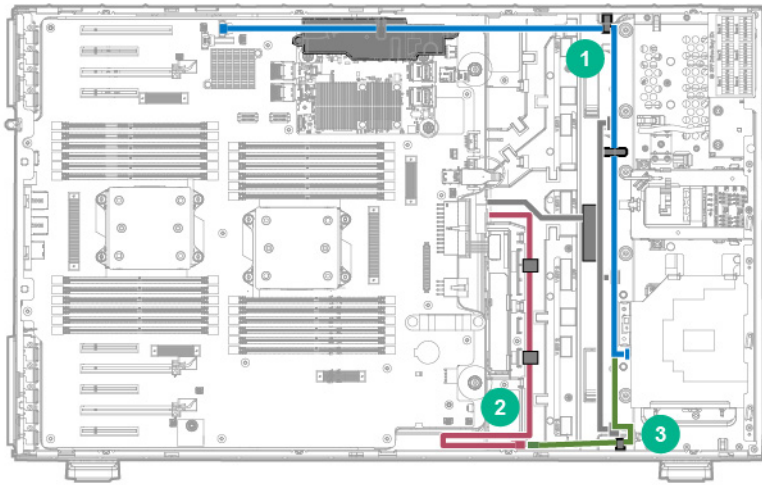

Item	Description
1	ODD signal cable to SATA port 5
2	Power supply backplane cable
3	ODD power cable

Front I/O module cabling

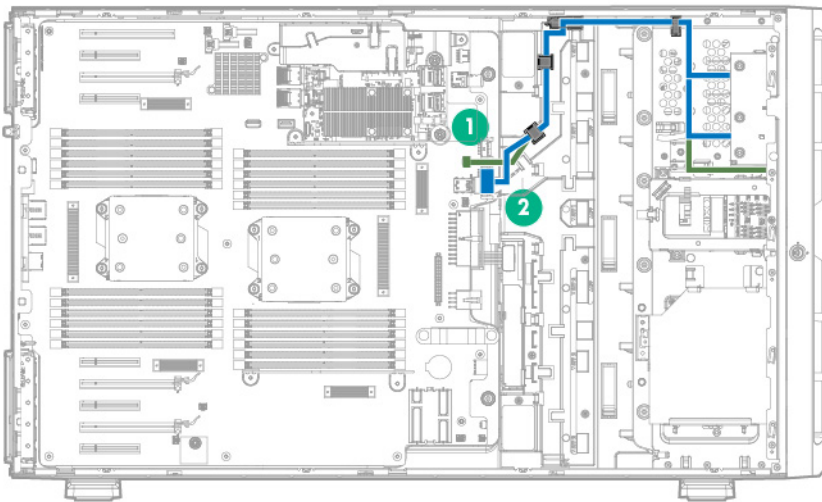

Item	Description
1	Ambient sensor cable
2	Front I/O LEDs and button cable

Systems Insight Display cabling

- SFF configuration

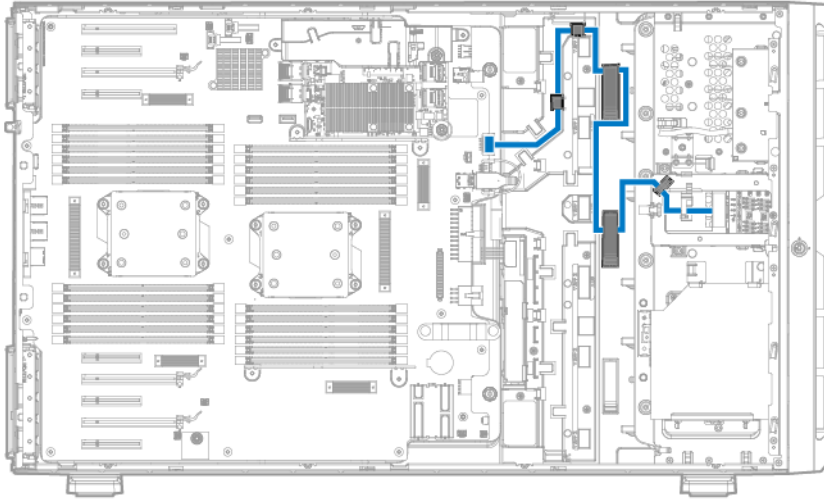

- LFF configuration

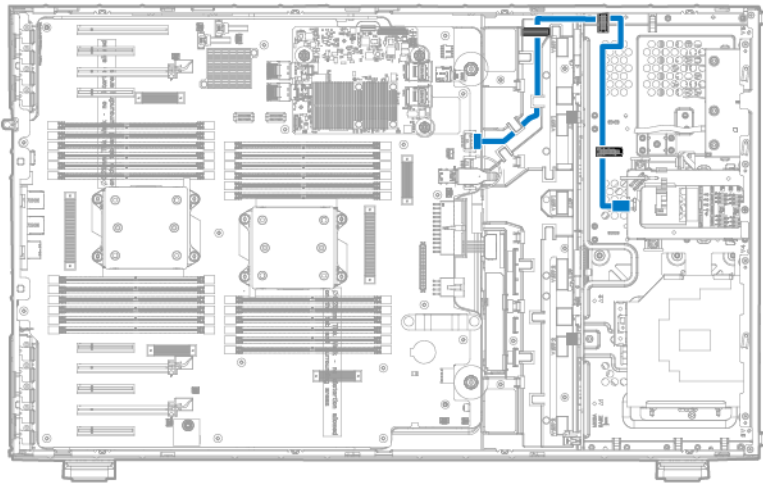

FBWC module backup power cabling

The FBWC solution is a separately purchased option. This server only supports FBWC module installation when a Smart Array P-Series controller is installed.

Depending on the controller option installed, the actual storage controller connectors might look different from what is shown in this section.

There are two FBWC module backup power cable connectors available for each group of PCIe connectors. For more information, see "System board components (on page 15)."

- Storage controller installed in slot 1 to 4

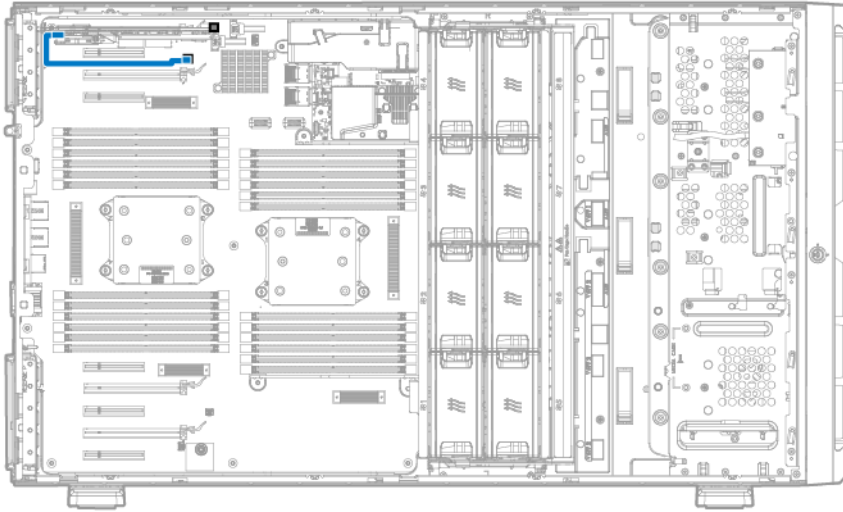

- Storage controller installed in slot 6 to 9

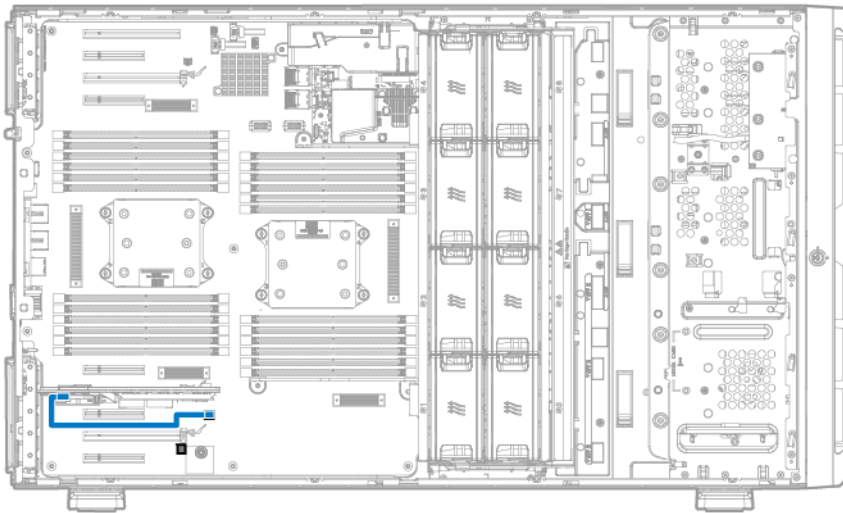

HPE Smart Storage Battery cabling

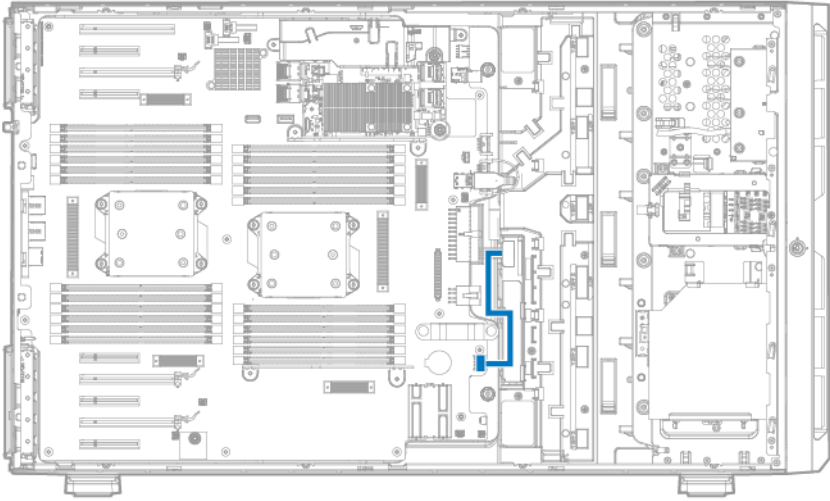

Power supply backplane cabling

- GPU power cabling

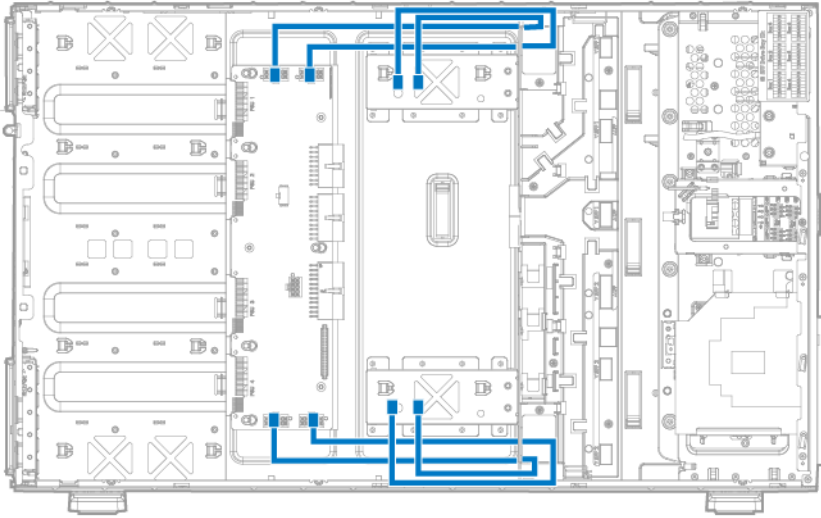

- x4 Power supply backplane cabling

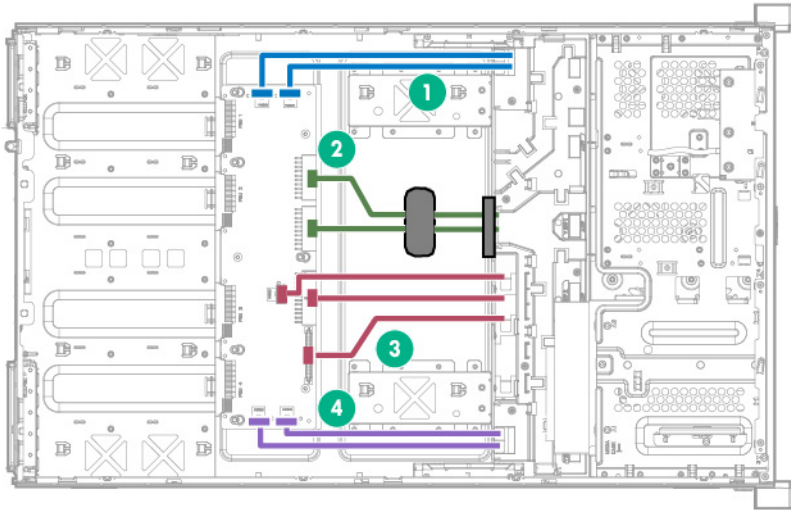

Item	Description
1	Power cables for GPU installed in slot 1 or 3
2	Drive cage backplane power cables
3	System board cables
4	Power cables for GPU installed in slot 6 or 8

- x2 power supply backplane cabling

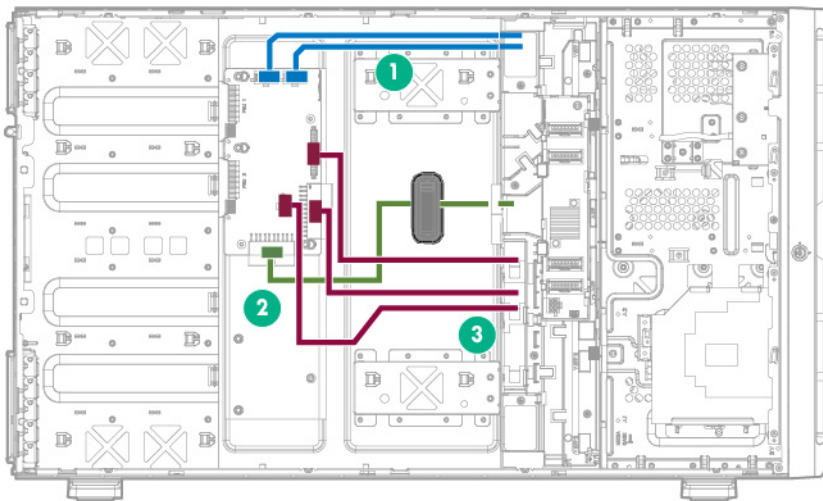

Item	Description
1	Power cables installed for GPU in slot 1 or 3
2	Power cable for drive cage backplane
3	System board cables

Drive cage power cabling

- LFF mode
 - x2 power supply backplane to 3 LFF drive backplanes (supports up to 24 LFF drives)

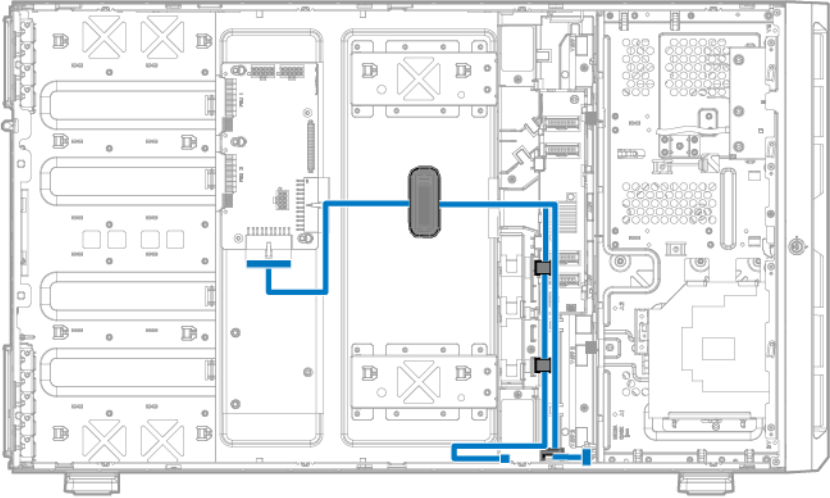

- SFF model
 - x2 power supply backplane to 3 SFF drive cages (supports up to 24 SFF drives)

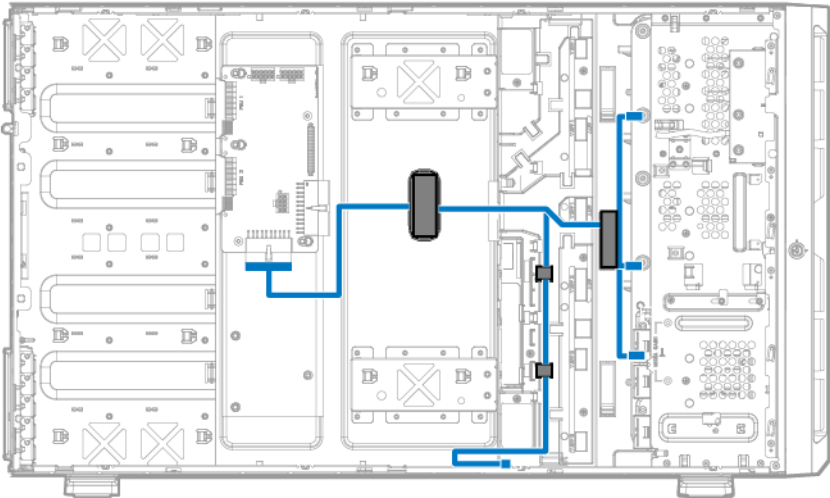

- o x4 power supply backplane to 3 SFF drive cages (supports up to 24 SFF drives)

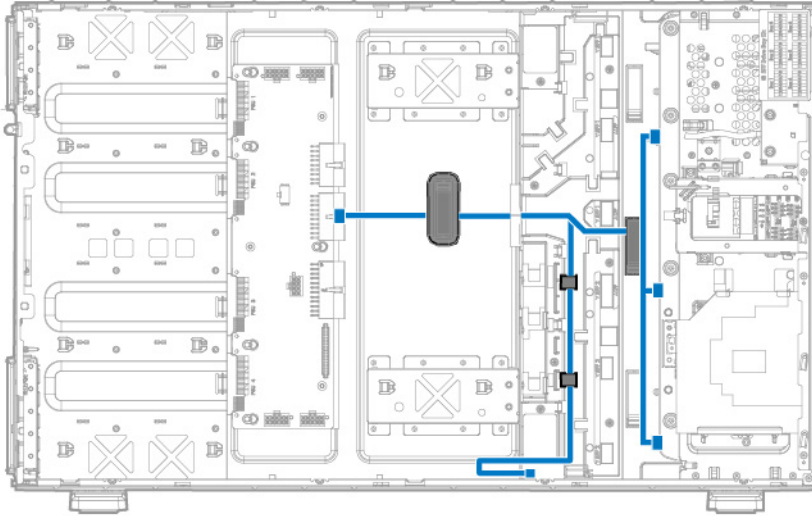

- o x4 power supply backplane to 6 SFF drive cages (supports up to 48 SFF drives)

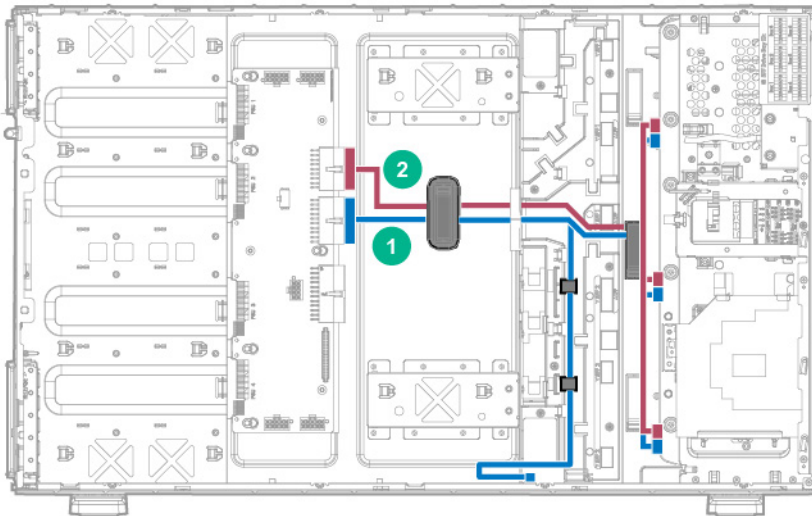

Item	Description
1	Power cable for SFF drive backplane in box 4, 5, 6, and ODD or media device
2	Power cable for drive backplane in box 1, 2, 3

Embedded SATA cabling

- LFF configuration

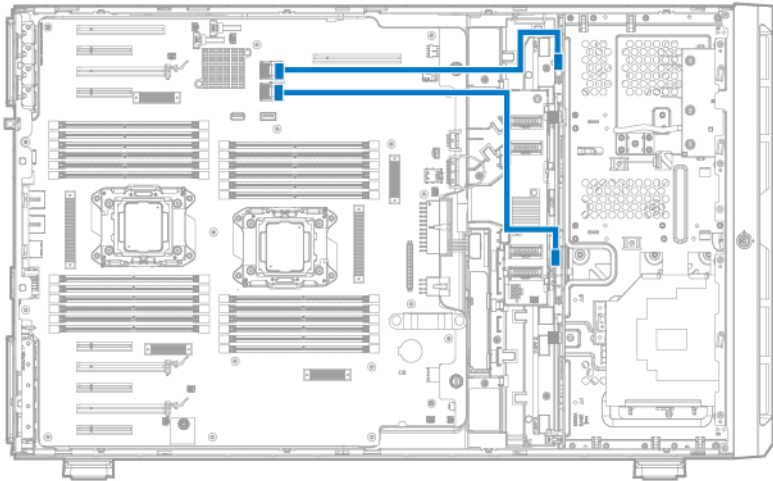

- SFF configuration

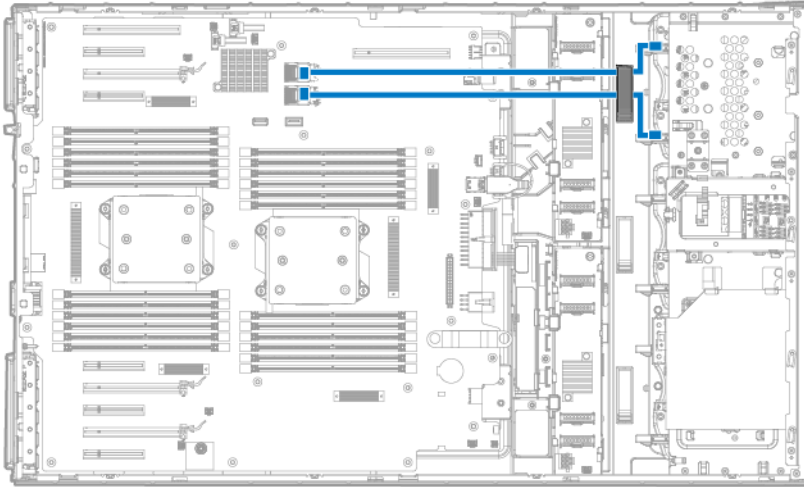

HPE Flexible Smart Array Controller Mini-SAS cabling

- SFF configuration

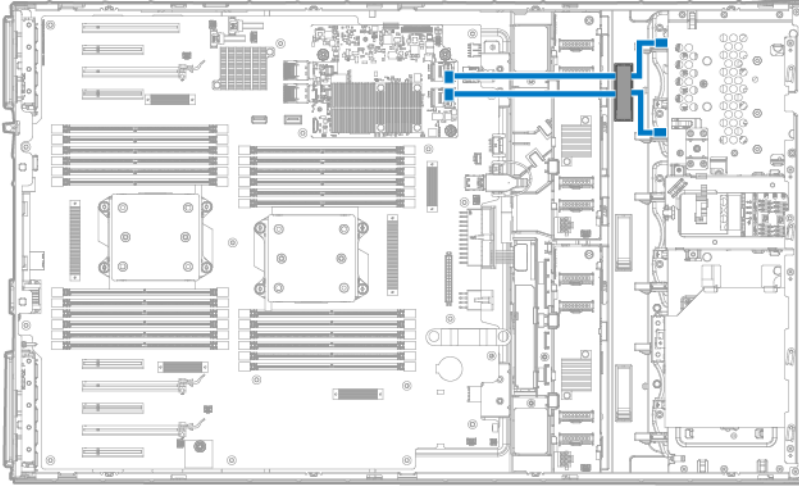

- LFF configuration

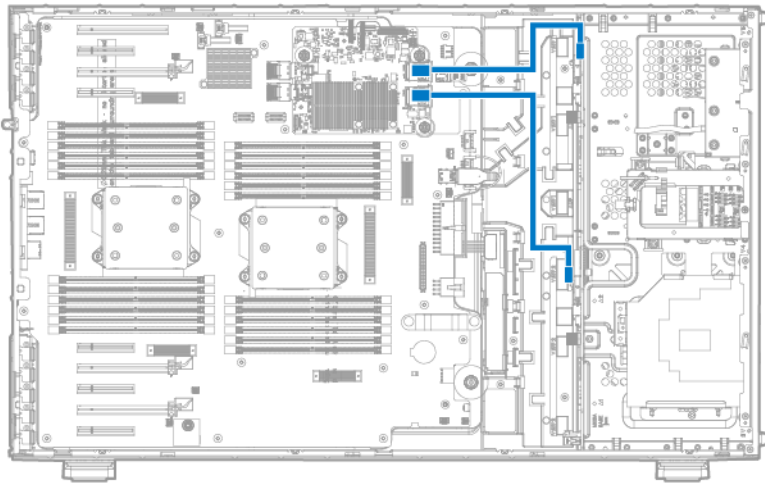

HPE Smart Array Controller Mini-SAS Y-cabling

Route the two ends of the Mini-SAS Y-cable through the cable management clips, and then connect them to the drive backplane:

- Cable routing if the Smart Array controller is installed in PCIe slot 1 to 4:

- SFF configuration

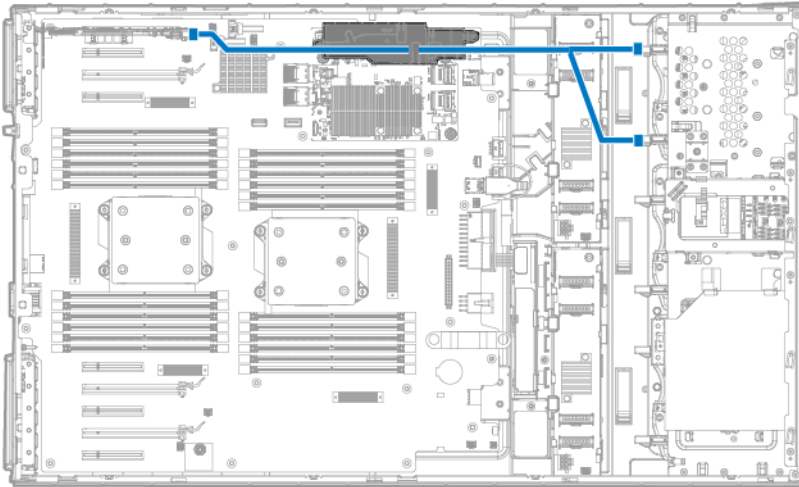

- LFF configuration

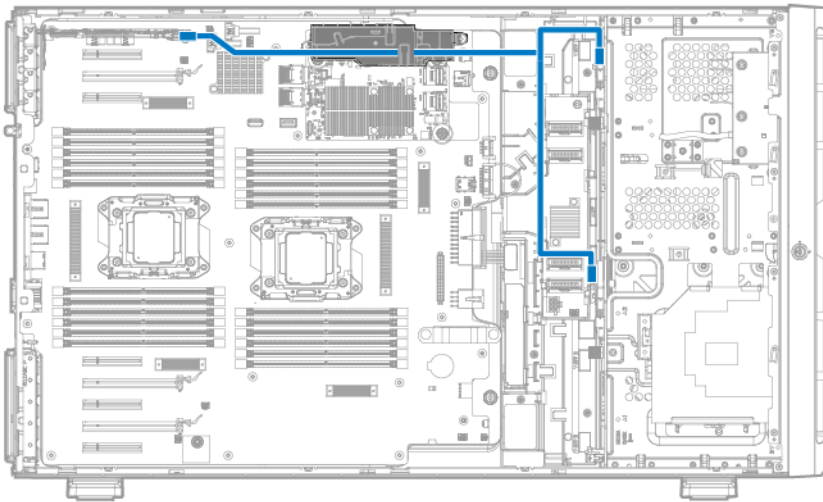

- Cable routing if the Smart Array controller is installed in PCIe slot 6 to 9:

- SFF configuration

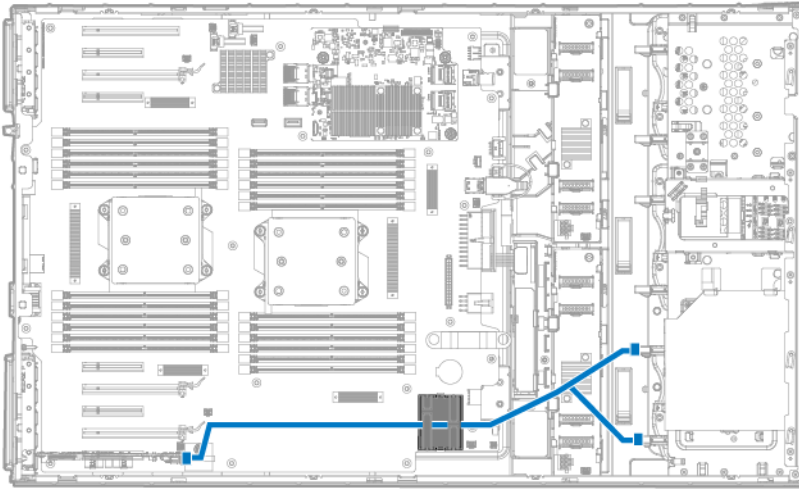

- LFF configuration

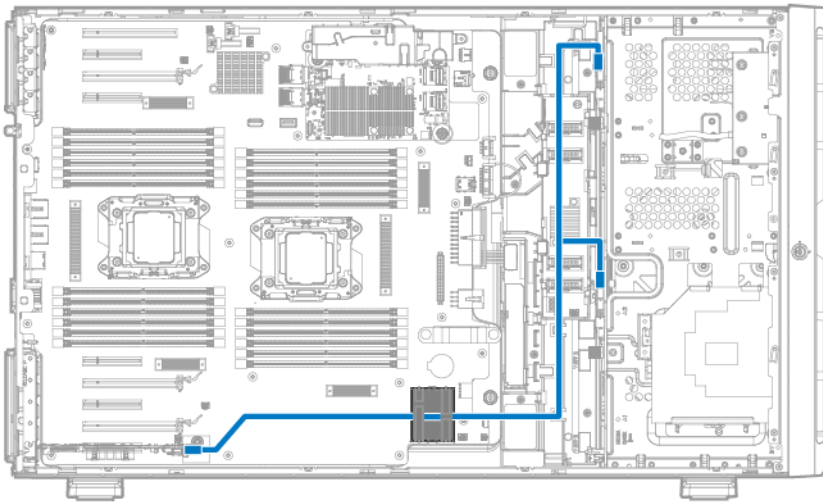

SAS Expander cabling

- One SAS Expander

- o LFF configuration

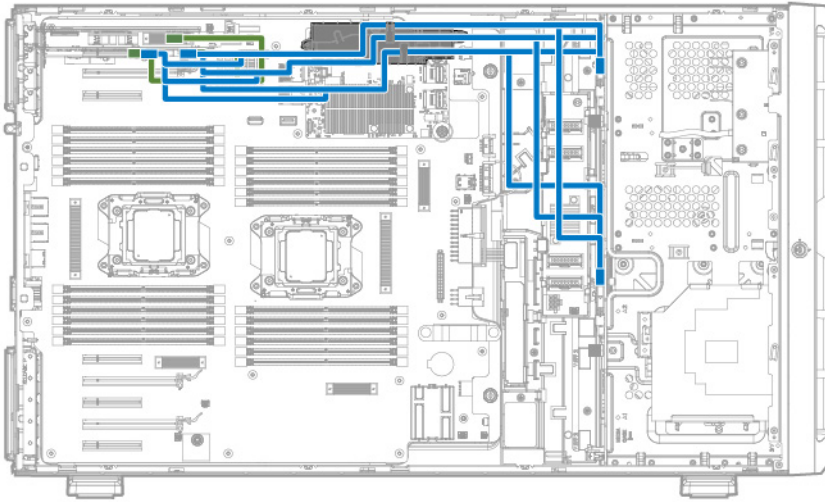

- o SFF configuration

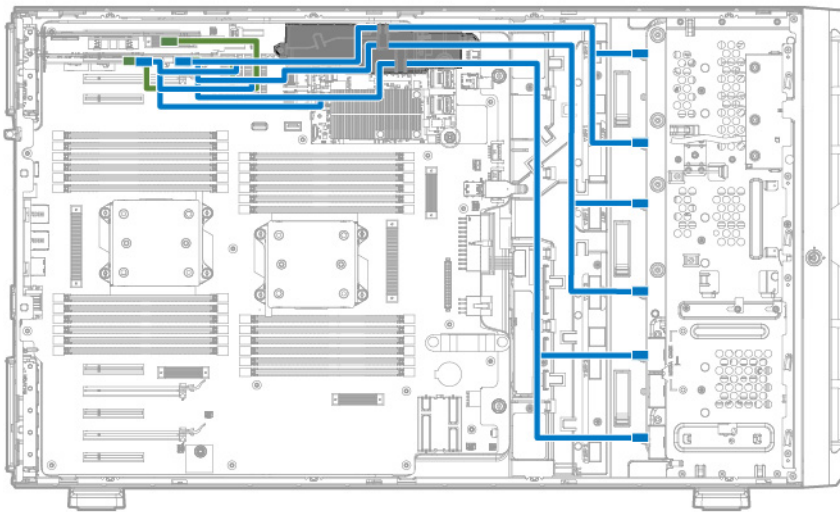

- Two SAS Expanders

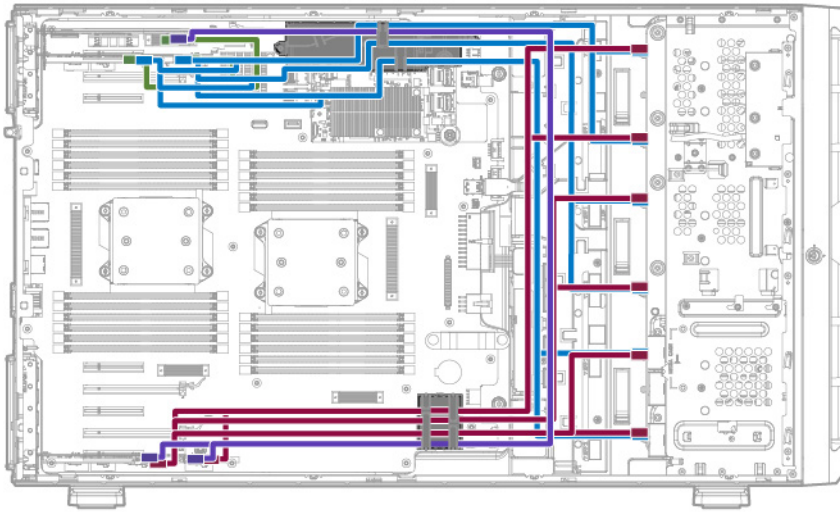

Express bay cabling

- Express bay bridge card installed in PCIe slot 3

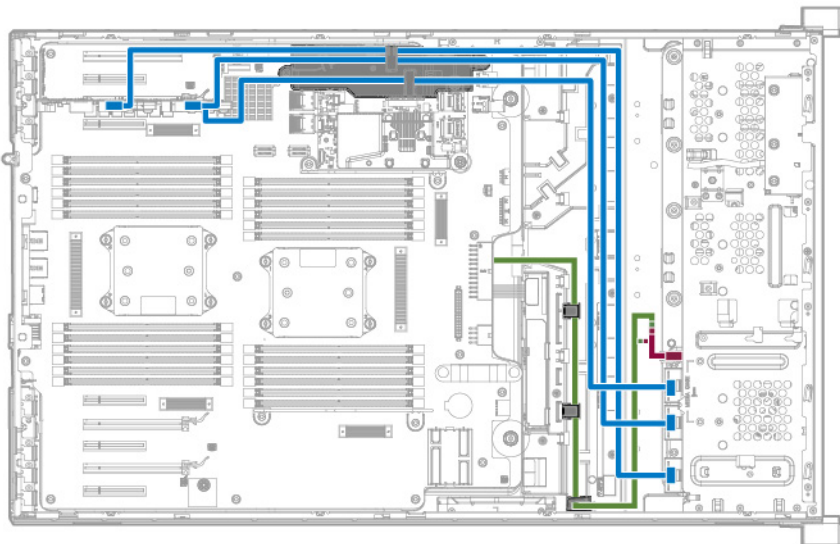

- Express bay bridge card installed in PCIe slot 6 or 8 and second processor installed

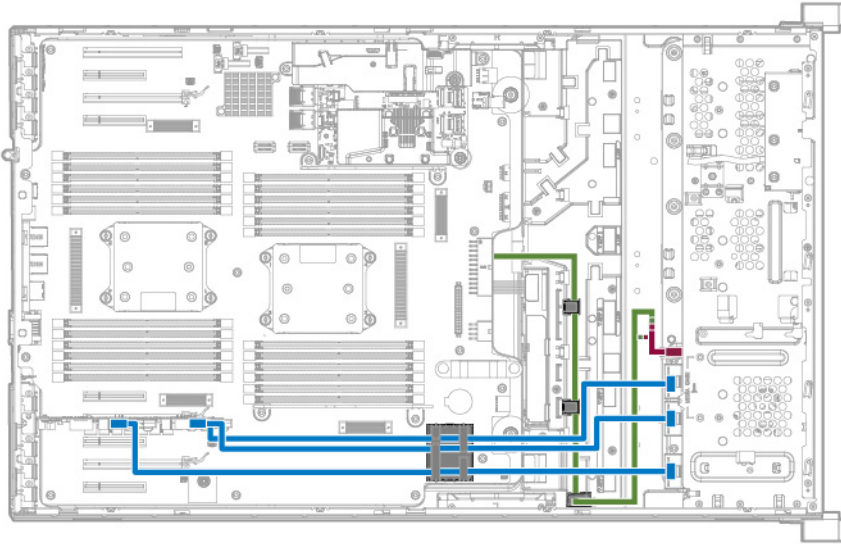

M.2 SSD cabling

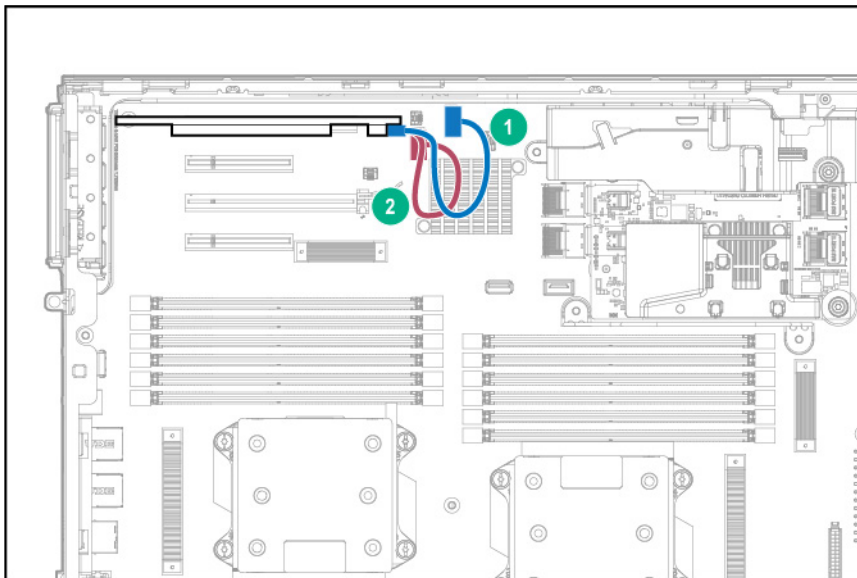

Item	Description
1	SATA cable of first M.2 SSD module
2	SATA cable of second M.2 SSD module

Software and configuration utilities

Server mode

The software and configuration utilities presented in this section operate in online mode, offline mode, or in both modes.

Software or configuration utility	Server mode
HPE iLO (on page 150)	Online and Offline
Active Health System (on page 150)	Online and Offline
iLO RESTful API support (on page 151)	Online and Offline
Integrated Management Log (on page 152)	Online and Offline
Intelligent Provisioning (on page 152, on page 152)	Offline
Insight Diagnostics (on page 153)	Online and Offline
Erase Utility (on page 153)	Offline
Scripting Toolkit for Windows and Linux (on page 153)	Online
Service Pack for ProLiant (on page 154)	Online and Offline
Smart Update Manager (on page 154)	Online and Offline
UEFI System Utilities (on page 154)	Offline
HPE Smart Storage Administrator (on page 157)	Online and Offline
FWUPDATE utility (on page 160)	Offline

Product QuickSpecs

For more information about product features, specifications, options, configurations, and compatibility, see the product QuickSpecs on the Hewlett Packard Enterprise website (<http://www.hpe.com/info/qs>).

HPE iLO

iLO is a remote server management processor embedded on the system boards of HPE ProLiant and Synergy servers. iLO enables the monitoring and controlling of servers from remote locations. HPE iLO management is a powerful tool that provides multiple ways to configure, update, monitor, and repair servers remotely. iLO (Standard) comes preconfigured on HPE servers **without an additional cost or license**.

Features that enhance server administrator productivity are licensed. For more information, see the iLO documentation on the Hewlett Packard Enterprise website (<http://www.hpe.com/info/ilo-docs>).

Active Health System

The Active Health System monitors and records changes in the server hardware and system configuration.

The Active Health System provides:

- Continuous health monitoring of over 1600 system parameters

- Logging of all configuration changes
- Consolidated health and service alerts with precise time stamps
- Agentless monitoring that does not affect application performance

The Agentless Management Service is available in the SPP, which can be downloaded from the Hewlett Packard Enterprise website (<http://www.hpe.com/servers/spp/download>). The Active Health System log can be downloaded manually from iLO 4 or Intelligent Provisioning and sent to Hewlett Packard Enterprise.

For more information, see the following documents:

- *iLO User Guide* on the Hewlett Packard Enterprise website (<http://www.hpe.com/info/ilo/docs>)
- *Intelligent Provisioning User Guide* on the Hewlett Packard Enterprise website (<http://www.hpe.com/info/intelligentprovisioning/docs>)

Active Health System data collection

The Active Health System does not collect information about your operations, finances, customers, employees, or partners.

Examples of data that is collected:

- Server model and serial number
- Processor model and speed
- Storage capacity and speed
- Memory capacity and speed
- Firmware/BIOS and driver versions and settings

The Active Health System does not parse or change operating system data from third-party error event log activities (for example, content created or passed through the operating system).

Active Health System log

The data collected by the Active Health System is stored in the Active Health System Log. The data is logged securely, isolated from the operating system, and separate from customer data.

When the Active Health System Log is full, new data overwrites the oldest data in the log.

It takes less than 5 minutes to download the Active Health System Log and send it to a Hewlett Packard Enterprise support professional to help you resolve an issue.

When you download and send Active Health System data to Hewlett Packard Enterprise, you agree to have Hewlett Packard Enterprise use the data for analysis, technical resolution, and quality improvements. The data that is collected is managed according to the privacy statement, available on the Hewlett Packard Enterprise website (<http://www.hpe.com/info/privacy>).

iLO RESTful API support

HPE iLO 4 firmware version 2.00 and later includes the iLO RESTful API. The iLO RESTful API is a management interface that server management tools can use to perform configuration, inventory, and monitoring of the ProLiant server via iLO. The iLO RESTful API uses basic HTTPS operations (GET, PUT, POST, DELETE, and PATCH) to submit or return JSON-formatted data with iLO web server.

HPE iLO 4 2.30 and later is Redfish 1.0-conformant while remaining backward compatible with the existing iLO RESTful API.

HPE iLO 4 supports the iLO RESTful API with ProLiant Gen8 and later servers. For more information about the iLO RESTful API, see the Hewlett Packard Enterprise website (<http://www.hpe.com/info/restfulinterface/docs>).

Integrated Management Log

The IML records hundreds of events and stores them in an easy-to-view form. The IML timestamps each event with 1-minute granularity.

You can view recorded events in the IML in several ways, including the following:

- From within HPE SIM
- From within the UEFI System Utilities (on page [154](#))
- From within the Embedded UEFI shell (on page [156](#))
- From within operating system-specific IML viewers:
 - For Windows: IML Viewer
 - For Linux: IML Viewer Application
- From within the iLO web interface
- From within Insight Diagnostics (on page [153](#))

Intelligent Provisioning

Intelligent Provisioning is a single-server deployment tool embedded in ProLiant Gen8 and later servers. Intelligent Provisioning simplifies ProLiant server setup and provides a reliable and consistent way to deploy ProLiant server configurations. This server does not support operating system installations but does support maintenance-related tasks using the Perform Maintenance window.

For more information about Intelligent Provisioning software and recovery media downloads, see the Hewlett Packard Enterprise website (<http://www.hpe.com/servers/intelligentprovisioning>). For consolidated drive and firmware update packages, see the Smart Update: Server Firmware and Driver Updates page on the Hewlett Packard Enterprise website (<http://www.hpe.com/info/SmartUpdate>).

Intelligent Provisioning

Intelligent Provisioning is a single-server deployment tool embedded in ProLiant Gen8 and later servers. Intelligent Provisioning simplifies ProLiant server setup and provides a reliable and consistent way to deploy ProLiant server configurations:

- Intelligent Provisioning prepares the system for installing "off-the-shelf" and Hewlett Packard Enterprise branded versions of operating system software and integrates optimized ProLiant server support software.
- Intelligent Provisioning provides installation help for Microsoft Windows, Red Hat and SUSE Linux, and VMware operating systems. For specific OS support, see the *Intelligent Provisioning Release Notes* on the Hewlett Packard Enterprise website (<http://www.hpe.com/info/intelligentprovisioning/docs>).
- Intelligent Provisioning provides maintenance-related tasks using the Perform Maintenance window.

For more information about Intelligent Provisioning software and recovery media downloads, see the Hewlett Packard Enterprise website (<http://www.hpe.com/servers/intelligentprovisioning>). For consolidated drive and firmware update packages, see the Smart Update: Server Firmware and Driver Updates page on the Hewlett Packard Enterprise website (<http://www.hpe.com/info/SmartUpdate>).

Insight Diagnostics

The Insight Diagnostics is a proactive server management tool, available in both offline and online versions. The tool provides diagnostics and troubleshooting capabilities to assist IT administrators who verify server installations, troubleshoot problems, and perform repair validation.

The Insight Diagnostics Offline Edition performs various in-depth system and component testing while the OS is not running. To run this utility, boot the server using Intelligent Provisioning (on page 152, on page 152).

The Insight Diagnostics Online Edition is a web-based application that captures system configuration and other related data needed for effective server management. Available in Microsoft Windows and Linux versions, the utility helps to ensure proper system operation.

For more information or to download the utility, see the Hewlett Packard Enterprise website (<http://www.hpe.com/info/InsightDiagnostics>). The Insight Diagnostics Online Edition is also available in the SPP ("[Service Pack for ProLiant](#)" on page 154).

Insight Diagnostics survey functionality

Insight Diagnostics (on page 153) provides survey functionality that gathers critical hardware and software information on ProLiant servers.

This functionality supports operating systems that the server supports. For operating systems supported by the server, see the Hewlett Packard Enterprise website (<http://www.hpe.com/info/supportos>).

If a significant change occurs between data-gathering intervals, the survey function marks the previous information and overwrites the survey data files to reflect the latest changes.

Survey functionality is installed with every Intelligent Provisioning-assisted Insight Diagnostics installation, or it can be installed through the SPP ("[Service Pack for ProLiant](#)" on page 154).

Erase Utility



CAUTION: Perform a backup before running the Erase Utility. The utility completes the following:

- Sets the system to its original factory state
- Deletes the current hardware configuration information, including array setup and disk partitioning
- Erases all connected hard drives completely.

Before using this utility, see the instructions in the *Intelligent Provisioning User Guide*.

Use the Erase Utility to erase drives and Active Health System logs, and to reset UEFI System Utilities settings. Run the Erase Utility if you must erase the system for the following reasons:

- You want to install a new operating system on a server with an existing operating system.
- You encounter an error when completing the steps of a factory-installed operating system installation.

To access the Erase Utility, click the Perform Maintenance icon from the Intelligent Provisioning home screen, and then select **Erase**.

For more information about the Erase Utility, see the *Intelligent Provisioning User Guide* on the Hewlett Packard Enterprise website (<http://www.hpe.com/info/intelligentprovisioning/docs>).

Scripting Toolkit for Windows and Linux

The STK for Windows and Linux is a server deployment product that delivers an unattended automated installation for high-volume server deployments. The STK is designed to support ProLiant servers. The

toolkit includes a modular set of utilities and important documentation that describes how to apply these tools to build an automated server deployment process.

The STK provides a flexible way to create standard server configuration scripts. These scripts are used to automate many of the manual steps in the server configuration process. This automated server configuration process cuts time from each deployment, making it possible to scale rapid, high-volume server deployments.

For more information or to download the STK, see the Hewlett Packard Enterprise website (<http://www.hpe.com/servers/proliant/stk>).

Service Pack for ProLiant

The SPP is a comprehensive systems software (drivers and firmware) solution delivered as a single package with major server releases. This solution uses SUM as the deployment tool and is tested on all supported ProLiant servers including HPE ProLiant Gen8 and later servers.

SPP allows the following operating modes:

- Online mode – The installation occurs while the host processor is running in the normal server environment.
- Offline mode – Boots a small Linux kernel and enables updates to occur on a single server.

For more information or to download SPP, see one of the following pages on the Hewlett Packard Enterprise website:

- Service Pack for ProLiant download page (<http://www.hpe.com/servers/spp/download>)
- Smart Update: Server Firmware and Driver Updates page (<http://www.hpe.com/info/SmartUpdate>)

Smart Update Manager

SUM is a product used to install and update firmware, drivers, and systems software on ProLiant servers. SUM provides a GUI, a command-line scriptable interface, and an interactive command-line scriptable interface. The interfaces allow you to deploy firmware, drivers, and software for supported nodes.

For more information about SUM, see the product page on the Hewlett Packard Enterprise website (<http://www.hpe.com/servers/hpsum>).

To download SUM, see the Hewlett Packard Enterprise website (<http://www.hpe.com/servers/hpsum/download>).

To access the *Smart Update Manager User Guide*, see the Hewlett Packard Enterprise Information Library (<http://www.hpe.com/info/sum-docs>).

UEFI System Utilities

The UEFI System Utilities is embedded in the system ROM. The UEFI System Utilities enable you to perform a wide range of configuration activities, including:

- Configuring system devices and installed options
- Enabling and disabling system features
- Displaying system information
- Selecting the primary boot controller
- Configuring memory options
- Selecting a language

- Launching other preboot environments such as the Embedded UEFI Shell and Intelligent Provisioning

For more information, see the UEFI System Utilities user guide for your product on the Hewlett Packard Enterprise website (<http://www.hpe.com/info/UEFI/docs>).

To access mobile-ready online help for the UEFI System Utilities and UEFI Shell, scan the QR code at the bottom of the screen. For on-screen help, press the **F1** key.

Using UEFI System Utilities

To use the System Utilities, use the following keys.

Action	Key
Access System Utilities	F9 during server POST
Navigate menus	Up and Down arrows
Select items	Enter
Save selections	F10
Access Help for a highlighted configuration option*	F1

*Scan the QR code on the screen to access online help for the UEFI System Utilities and UEFI Shell.

Default configuration settings are applied to the server at one of the following times:

- Upon the first system power-up
- After defaults have been restored

Default configuration settings are sufficient for typical server operations; however, you can modify configuration settings as needed. The system prompts you for access to the UEFI System Utilities each time the system is powered up.

Flexible boot control

This feature enables you to do the following:

- Add Boot Options:
 - Browse all FAT16 and FAT32 file systems.
 - To add a new UEFI boot option, select an X64 UEFI application with an .EFI extension. For example, adding an OS boot loader or other UEFI application as a new UEFI boot option.

The new boot option is appended to the boot-order list. When you select a file, you are prompted to enter the boot option description. This description, and any optional data to be passed to an .EFI application, is then displayed in the boot menu.
- Boot to System Utilities

After pre-POST, the boot options screen appears. During this time, you can access the UEFI System Utilities by pressing the **F9** key.
- Choose between supported modes:
 - Legacy BIOS Boot Mode
 - UEFI Boot Mode



IMPORTANT: If the default boot mode settings are different than the user-defined settings, the system may not boot the OS installation if the defaults are restored. To avoid this issue, use the User Defined Defaults feature in UEFI System Utilities to override the factory default settings.

For more information, see the UEFI System Utilities user guide for your product on the Hewlett Packard Enterprise website (<http://www.hpe.com/info/UEFI/docs>).

Restoring and customizing configuration settings

You can reset all configuration settings to the factory default settings, or you can restore and use the system default configuration settings.

You can also configure default settings as necessary, and then save the configuration as the custom default configuration. When the system loads the default settings, it uses the custom default settings instead of the factory defaults.

Secure Boot configuration

Secure Boot is integrated in the UEFI specification on which the Hewlett Packard Enterprise implementation of UEFI is based. Secure Boot is implemented in the BIOS and does not require special hardware. Secure Boot ensures that each component launched during the boot process is digitally signed. Secure Boot also ensures that the signature is validated against a set of trusted certificates embedded in the UEFI BIOS. Secure Boot validates the software identity of the following components in the boot process:

- UEFI drivers loaded from PCIe cards
- UEFI drivers loaded from mass storage devices
- Preboot UEFI shell applications
- OS UEFI boot loaders

Once enabled, only firmware components and operating systems with boot loaders that have an appropriate digital signature can execute during the boot process. Only operating systems that support Secure Boot and have an EFI boot loader signed with one of the authorized keys can boot. For more information about supported operating systems, see the UEFI System Utilities and Shell release notes for your server on the Hewlett Packard Enterprise website (<http://www.hpe.com/info/UEFI/docs>).

A physically present user can customize the certificates embedded in the UEFI BIOS by adding or removing their own certificates.

When Secure Boot is enabled, the System Maintenance Switch does not restore all manufacturing defaults when set to the ON position. For security reasons, the following are not restored to defaults when the System Maintenance Switch is in the ON position:

- Secure Boot is not disabled and remains enabled.
- The Boot Mode remains in UEFI Boot Mode even if the default boot mode is Legacy Boot Mode.
- The Secure Boot Database is not restored to its default state.
- iSCSI Software Initiator configuration settings are not restored to defaults.

Embedded UEFI shell

The system BIOS in all ProLiant Gen9 servers includes an Embedded UEFI Shell in the ROM. The UEFI Shell environment provides an API, a command-line prompt, and a set of CLIs that allow scripting, file manipulation, and system information. These features enhance the capabilities of the UEFI System Utilities.

For more information, see the following documents:

- *UEFI Shell User Guide for HPE ProLiant Gen9 Servers* on the Hewlett Packard Enterprise website (<http://www.hpe.com/info/UEFI/docs>)
- *UEFI Shell Specification* on the UEFI website (<http://www.uefi.org/specifications>)

Embedded Diagnostics option

The system BIOS in all ProLiant Gen9 servers includes an Embedded Diagnostics option in the ROM. The Embedded Diagnostics option can run comprehensive diagnostics of the server hardware, including processors, memory, drives, and other server components.

For more information on the Embedded Diagnostics option, see the UEFI System Utilities user guide for your server on the Hewlett Packard Enterprise website (<http://www.hpe.com/info/UEFI/docs>).

iLO RESTful API support for UEFI

The ProLiant Gen9 servers include support for a UEFI-compliant System BIOS, along with UEFI System Utilities and Embedded UEFI Shell preboot environments. ProLiant Gen9 servers also support configuring the UEFI BIOS settings using the iLO RESTful API, a management interface that server management tools can use to perform configuration, inventory, and monitoring of a ProLiant server. The iLO RESTful API uses basic HTTPS operations (GET, PUT, POST, DELETE, and PATCH) to submit or return JSON-formatted data with iLO web server.

For more information about the iLO RESTful API and the RESTful Interface Tool, see the Hewlett Packard Enterprise website (<http://www.hpe.com/info/restfulinterface/docs>).

Re-entering the server serial number and product ID

After you replace the system board, you must re-enter the server serial number and the product ID:

1. During the server startup sequence, press the **F9** key to access UEFI System Utilities.
2. Select **System Configuration > BIOS/Platform Configuration (RBSU) > Advanced Options > Advanced System ROM Options > Serial Number**, and then press the **Enter** key.
3. Enter the serial number and press the **Enter** key.

The following message appears:

The serial number should only be modified by qualified service personnel. This value should always match the serial number located on the chassis.

4. To clear the warning, press the **Enter** key.
5. Enter the serial number and press the **Enter** key.
6. Select **Product ID**.

The following warning appears:

Warning: The Product ID should ONLY be modified by qualified service personnel. This value should always match the Product ID located on the chassis.

7. Enter the product ID and press the **Enter** key.
8. To confirm exiting System Utilities, press the **F10** key.

The server automatically reboots.

Utilities and features

HPE Smart Storage Administrator

The HPE SSA is a configuration and management tool for HPE Smart Array controllers. Starting with HPE ProLiant Gen8 servers, HPE SSA replaces ACU with an enhanced GUI and additional configuration features.

The HPE SSA exists in three interface formats: the HPE SSA GUI, the HPE SSA CLI, and HPE SSA Scripting. Although all formats provide support for configuration tasks, some of the advanced tasks are available in only one format.

Some HPE SSA features include the following:

- Supports online array capacity expansion, logical drive extension, assignment of online spares, and RAID or stripe size migration
- Provides diagnostic and SmartSSD Wear Gauge functionality on the Diagnostics tab
- For supported controllers, provides access to additional features.

For more information about HPE SSA, see the Hewlett Packard Enterprise website (<http://www.hpe.com/servers/ssa>).

Automatic Server Recovery

ASR is a feature that causes the system to restart when a catastrophic operating system error occurs, such as a blue screen, ABEND, or panic. A system fail-safe timer, the ASR timer, starts when the System Management driver, also known as the Health Driver, is loaded. When the operating system is functioning properly, the system periodically resets the timer. However, when the operating system fails, the timer expires and restarts the server.

ASR increases server availability by restarting the server within a specified time after a system hang. You can disable ASR from the System Management Homepage or through UEFI System Utilities.

USB support

Hewlett Packard Enterprise provides both standard USB 2.0 support and legacy USB 2.0 support. Standard support is provided by the OS through the appropriate USB device drivers. Before the OS loads, Hewlett Packard Enterprise supports USB devices through legacy USB support, which is enabled by default in the system ROM.

Legacy USB support provides USB functionality in environments where USB support is not available normally. Specifically, Hewlett Packard Enterprise provides legacy USB functionality for the following:

- POST (system boot)
- UEFI System Utilities
- Preboot UEFI shell
- DOS
- Operating environments that do not provide native USB support

External USB functionality

Hewlett Packard Enterprise provides external USB support to enable local connection of USB devices for server administration, configuration, and diagnostic procedures.

For additional security, external USB functionality can be disabled through USB options in UEFI System Utilities.

USB support

Hewlett Packard Enterprise servers support both USB 2.0 ports and USB 3.0 ports. Both port types support installing all types of USB devices (USB 1.0, USB 2.0, and USB 3.0), but might run at lower speeds in specific situations:

- USB 3.0 capable devices operate at USB 2.0 speeds when installed in a USB 2.0 port.

- In UEFI Boot Mode, Hewlett Packard Enterprise provides legacy USB support in the preboot environment before the operating system loading for USB 1.0, USB 2.0, and USB 3.0 speeds.
- In Legacy BIOS Boot Mode, Hewlett Packard Enterprise provides legacy USB support in the preboot environment before the operating system loading for USB 1.0 and USB 2.0 speeds. USB 3.0 ports can be used with all devices in Legacy BIOS Boot Mode but are not available at USB 3.0 speeds in the preboot environment. Standard USB support (USB support from within the operating system) is provided by the OS through the appropriate USB device drivers. Support for USB 3.0 varies by operating system.

For maximum compatibility of USB 3.0 devices with all operating systems, Hewlett Packard Enterprise provides a configuration setting for USB 3.0 Mode. Auto is the default setting. This setting impacts USB 3.0 devices when connected to USB 3.0 ports in the following manner:

- **Auto (default)**—If configured in Auto Mode, USB 3.0 capable devices operate at USB 2.0 speeds in the preboot environment and during boot. When a USB 3.0 capable OS USB driver loads, USB 3.0 devices transition to USB 3.0 speeds. This mode is compatible with operating systems that do not support USB 3.0 while allowing USB 3.0 devices to operate at USB 3.0 speeds with state-of-the-art operating systems.
- **Enabled**—If Enabled, USB 3.0 capable devices operate at USB 3.0 speeds at all times (including the preboot environment) when in UEFI Boot Mode. Do not use this mode with operating systems that do not support USB 3.0. If operating in Legacy Boot BIOS Mode, the USB 3.0 ports cannot function in the preboot environment and are not bootable.
- **Disabled**—If configured for Disabled, USB 3.0 capable devices function at USB 2.0 speeds at all times.

The pre-OS behavior and default operation of the USB ports is configurable in the UEFI System Utilities. For more information, see the UEFI System Utilities user guide for your product on the Hewlett Packard Enterprise website (<http://www.hpe.com/info/UEFI/docs>).

External USB functionality

Hewlett Packard Enterprise provides external USB support to enable local connection of USB devices for server administration, configuration, and diagnostic procedures.

For additional security, external USB functionality can be disabled through USB options in UEFI System Utilities.

Redundant ROM support

The server enables you to upgrade or configure the ROM safely with redundant ROM support. The server has a single ROM that acts as two separate ROM images. In the standard implementation, one side of the ROM contains the current ROM program version, while the other side of the ROM contains a backup version.

NOTE: The server ships with the same version programmed on each side of the ROM.

Safety and security benefits

When you flash the system ROM, the flashing mechanism writes over the backup ROM and saves the current ROM as a backup, enabling you to switch easily to the alternate ROM version if the new ROM becomes corrupted for any reason. This feature protects the existing ROM version, even if you experience a power failure while flashing the ROM.

Keeping the system current

Updating firmware or System ROM

Multiple methods exist to update the firmware or System ROM:

- Service Pack for ProLiant (on page 154)
- FWUPDATE utility (on page 160)
- FWUpdate command from within the Embedded UEFI shell (on page 160)
- Firmware Update application in UEFI System Utilities ("[Firmware Update application in the UEFI System Utilities](#)" on page 161)
- Online Flash components (on page 161)

Product entitlement is required to perform updates. For more information, see "Accessing updates ("[Accessing Hewlett Packard Enterprise Support](#)" on page 173)."

FWUPDATE utility

The FWUPDATE utility enables you to upgrade the system firmware (BIOS).

To use the utility to upgrade the firmware:

1. Download the FWUPDATE flash component from the Hewlett Packard Enterprise Support Center website (<http://www.hpe.com/support/hpesc>).
2. Save the FWUPDATE flash components to a USB key.
3. Set the boot order so that the USB key will boot first using one of the following options:
 - Configure the boot order so that the USB key is the first bootable device.
 - Press the **F11** key (Boot Menu) when prompted during system boot to access the **One-Time Boot Menu**. This menu allows you to select the boot device for a specific boot and does not modify the boot order configuration settings.
4. Insert the USB key into an available USB port.
5. Boot the system.

The FWUPDATE utility checks the system and provides a choice (if more than one exists) of available firmware revisions.

To download the flash components, see the Hewlett Packard Enterprise Support Center website (<http://www.hpe.com/support/hpesc>).

For more information about One-Time Boot Menu, see the UEFI System Utilities user guide for your product on the Hewlett Packard Enterprise website (<http://www.hpe.com/info/UEFI/docs>).

FWUpdate command from within the Embedded UEFI Shell

For systems configured in either boot mode, update the firmware:

1. Access the System ROM Flash Binary component for your server from the Hewlett Packard Enterprise Support Center website (<http://www.hpe.com/support/hpesc>). When searching for the component, always select **OS Independent** to locate the binary file.
2. Copy the binary file to a USB media or iLO virtual media.
3. Attach the media to the server.
4. Boot to Embedded Shell.
5. To obtain the assigned file system volume for the USB key, enter the `Map -r` command.

For more information about accessing a file system from the shell, see the *UEFI Shell User Guide for HPE ProLiant Gen9 Servers* on the Hewlett Packard Enterprise website (<http://www.hpe.com/info/UEFI/docs>).

6. Change to the file system that contains the System ROM Flash Binary component for your server. Enter one of the `fsx` file systems available, such as `fs0` or `fs1`, and press the **Enter** key.
7. Use the `cd` command to change from the current directory to the directory that contains the binary file.
8. Enter the `fwupdate -d BIOS -f <filename>` command to flash the system ROM.
For help on the FWUPDATE command, enter the following command:

```
help fwupdate -b
```
9. Reboot the server.
A reboot is required after the firmware update for the updates to take effect, and for hardware stability to be maintained.

For more information about the commands used in this procedure, see the *UEFI Shell User Guide for HPE ProLiant Gen9 Servers* on the Hewlett Packard Enterprise website (<http://www.hpe.com/info/UEFI/docs>).

Firmware Update application in the UEFI System Utilities

For systems configured in either boot mode, update the firmware:

1. Access the System ROM Flash Binary component for your server from the Hewlett Packard Enterprise Support Center website (<http://www.hpe.com/support/hpesc>). When searching for the component, always select **Cross operating system** to locate the binary file.
2. Copy the binary file to a USB media or iLO virtual media.
3. Attach the media to the server.
4. During POST, press **F9** to enter System Utilities.
5. Select **Embedded Applications** → **Firmware Update** → **System ROM** → **Select Firmware File**.
6. Select the device containing the flash file.
7. Select the flash file. This step may take a few moments to complete.
8. Select **Start firmware update** and allow the process to complete.
9. Reboot the server. A reboot is required after the firmware update for the updates to take effect and for hardware stability to be maintained.

Online Flash components

This component provides updated system firmware that can be installed directly on supported operating systems. Additionally, when used in conjunction with SUM ("Smart Update Manager" on page 154), this Smart Component allows the user to update firmware on remote servers from a central location. This remote deployment capability eliminates the need for the user to be physically present at the server to perform a firmware update.

Drivers



IMPORTANT: Always perform a backup before installing or updating device drivers.

The server includes new hardware that may not have driver support on all OS installation media.

If you are installing an Intelligent Provisioning-supported OS, use Intelligent Provisioning (on page 152, on page 152) and its Configure and Install feature to install the OS and latest supported drivers.

If you do not use Intelligent Provisioning to install an OS, drivers for some of the new hardware are required. These drivers, as well as other option drivers, ROM images, and value-add software can be downloaded as part of an SPP.

If you are installing drivers from SPP, be sure that you are using the latest SPP version that your server supports. To verify that your server is using the latest supported version and for more information about SPP, see the Hewlett Packard Enterprise website (<http://www.hpe.com/servers/spp/download>).

To locate the drivers for a particular server, go to the Hewlett Packard Enterprise Support Center website (<http://www.hpe.com/support/hpesc>). Under **Select your HPE product**, enter the product name or number and click **Go**.

Software and firmware

Update software and firmware before using the server for the first time, unless any installed software or components require an older version.

For system software and firmware updates, use one of the following sources:

- Download the SPP ("Service Pack for ProLiant" on page 154) from the Hewlett Packard Enterprise website (<http://www.hpe.com/servers/spp/download>).
- Download individual drivers, firmware, or other systems software components from the server product page in the Hewlett Packard Enterprise Support Center website (<http://www.hpe.com/support/hpesc>).

Operating System Version Support

For information about specific versions of a supported operating system, refer to the operating system support matrix (<http://www.hpe.com/info/ossupport>).

Version control

The VCRM and VCA are web-enabled Insight Management Agents tools that SIM uses to schedule software update tasks to the entire enterprise.

- VCRM manages the repository for SPP. Administrators can do the following:
 - View the SPP contents
 - Configure VCRM to update the repository automatically with internet downloads of the latest software and firmware from Hewlett Packard Enterprise
- VCA compares installed software versions on the node with updates available in the VCRM managed repository. Administrators configure VCA to point to a repository managed by VCRM.

For more information about version control tools, see the following documents on the Hewlett Packard Enterprise website (<http://www.hpe.com/info/enterprise/docs>):

- *Systems Insight Manager User Guide*
- *Version Control Agent User Guide*
- *Version Control Repository Manager User Guide*

To locate the documents, do the following:

1. Select **Insight Management** from the available options in Products and Solutions.
2. Select **Version Control** from the available options in Models / Subcategories.
3. Locate and download the latest document.

Operating systems and virtualization software support for ProLiant servers

For information about specific versions of a supported operating system, see the Hewlett Packard Enterprise website (<http://www.hpe.com/info/ossupport>).

HPE Technology Service Portfolio

HPE Technology Services deliver confidence, reduces risk and helps customers realize agility and stability. We help customers succeed through Hybrid IT by simplifying and enriching the on-premise experience, informed by public cloud qualities and attributes. HPE Support Services enables you to choose the right service level, length of coverage and response time to fit your business needs. Connect to HPE to help prevent problems and solve issues faster. By connecting, you will receive 24x7 monitoring, prefailure alerts, automatic call logging, and automatic parts dispatch. To learn more about getting connected, see the Hewlett Packard Enterprise website (<http://www.hpe.com/services/getconnected>).

For more information about support services, see the Hewlett Packard Enterprise website (<http://www.hpe.com/services/support>).

Utilize our consulting expertise in the following areas:

- Private or hybrid cloud computing
- Big data and mobility requirements
- Improving data center infrastructure
- Better use of server, storage, and networking technology

For more information, see the Hewlett Packard Enterprise website (<http://www.hpe.com/services/consulting>).

Change control and proactive notification

Hewlett Packard Enterprise offers Change Control and Proactive Notification to notify customers 30 to 60 days in advance of the following:

- Upcoming hardware and software changes
- Bulletins
- Patches

Let us know what Hewlett Packard Enterprise commercial products you own and we will send you the latest updates to keep your business running smoothly.

For more information, see the Hewlett Packard Enterprise website (<http://www.hpe.com/info/pcn>).

Troubleshooting

Troubleshooting resources

The *HPE ProLiant Gen9 Troubleshooting Guide, Volume I: Troubleshooting* provides procedures for resolving common problems and comprehensive courses of action for fault isolation and identification, issue resolution, and software maintenance on ProLiant servers and server blades. To view the guide, select a language:

- English (http://www.hpe.com/support/Gen9_TSG_en)
- French (http://www.hpe.com/support/Gen9_TSG_fr)
- Spanish (http://www.hpe.com/support/Gen9_TSG_es)
- German (http://www.hpe.com/support/Gen9_TSG_de)
- Japanese (http://www.hpe.com/support/Gen9_TSG_ja)
- Simplified Chinese (http://www.hpe.com/support/Gen9_TSG_zh_cn)

The *HPE ProLiant Gen9 Troubleshooting Guide, Volume II: Error Messages* provides a list of error messages and information to assist with interpreting and resolving error messages on ProLiant servers and server blades. To view the guide, select a language:

- English (http://www.hpe.com/support/Gen9_EMG_en)
- French (http://www.hpe.com/support/Gen9_EMG_fr)
- Spanish (http://www.hpe.com/support/Gen9_EMG_es)
- German (http://www.hpe.com/support/Gen9_EMG_de)
- Japanese (http://www.hpe.com/support/Gen9_EMG_ja)
- Simplified Chinese (http://www.hpe.com/support/Gen9_EMG_zh_cn)

System battery replacement

If the server no longer automatically displays the correct date and time, then replace the battery that provides power to the real-time clock. Under normal use, battery life is 5 to 10 years.



WARNING: The computer contains an internal lithium manganese dioxide, a vanadium pentoxide, or an alkaline battery pack. A risk of fire and burns exists if the battery pack is not properly handled. To reduce the risk of personal injury:

- Do not attempt to recharge the battery.
- Do not expose the battery to temperatures higher than 60°C (140°F).
- Do not disassemble, crush, puncture, short external contacts, or dispose of in fire or water.
- Replace only with the spare designated for this product.

To remove the component:

1. Do one of the following:
 - For tower models, open and remove the tower bezel ("[Remove the tower bezel](#)" on page 31).
 - For rack models, if installed, remove the security bezel ("[Remove the security bezel \(optional\)](#)" on page 31).
2. Power down the server (on page 30).
3. Remove all power:
 - a. Disconnect each power cord from the power source.
 - b. Disconnect each power cord from the server.
4. Do one of the following:
 - For tower models, place the server on a flat, level surface with the access panel facing up.
 - For rack models, extend the server from the rack (on page 34).
5. Remove the access panel (on page 32).
6. Remove the fan cage (on page 37).
7. Locate the battery on the system board ("[System board components](#)" on page 15).
8. If the system battery is secured by a metal tab, do the following:
 - a. Use your finger or a small flat-bladed, nonconductive tool to press the metal tab. This will partially release the battery from the socket.
 - b. Remove the battery.

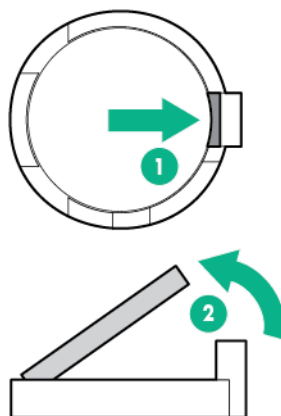

9. If the system battery is secured by a plastic outer clip, do the following:
 - a. Use a small flat-bladed, nonconductive tool to carefully lift the front of the battery from the socket.
 - b. Remove the battery.

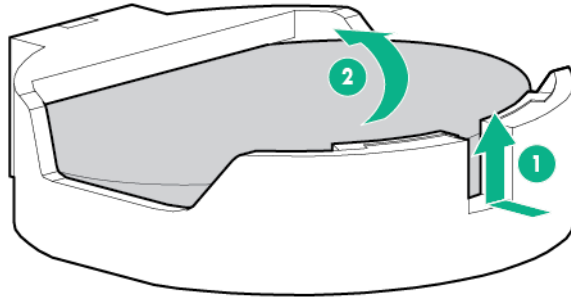

IMPORTANT: Replacing the system board battery resets the system ROM to its default configuration. After replacing the battery, use BIOS/Platform Configuration (RBSU) in the UEFI System Utilities (on page 154) to reconfigure the system.

To install the component:

1. If the battery socket design uses a metal tab to secure the battery, insert the battery with the "+" side facing up on the socket, and then press the battery down to secure it in place.

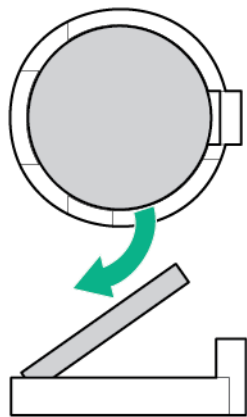

2. If the battery socket design has a plastic outer lip to secure the battery, insert the battery with the "+" side facing up underneath the outer lip of the socket, and then press the battery down to secure it in place.

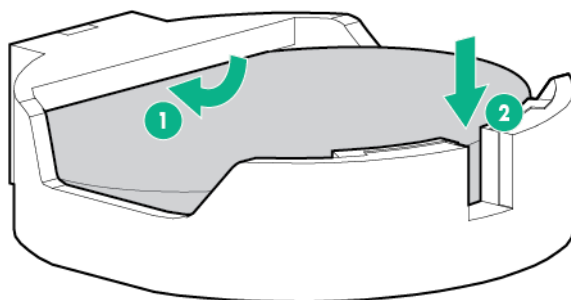

3. Install the access panel (on page [33](#)).
4. Do one of the following:
 - If the server is in a tower configuration, return the server to an upright position.
 - If the server is in a rack configuration, slide the server into the rack.
5. Connect each power cord to the server.
6. Connect each power cord to the power source.
7. Power up the server ("[Powering up the server](#)" on page [30](#)).
8. Do one of the following:
 - For tower models, install the tower bezel (on page [31](#)).
 - For rack models, install the security bezel ("[Security bezel option](#)" on page [50](#)).

For more information about battery replacement or proper disposal, contact an authorized reseller or an authorized service provider.

Warranty and regulatory information

Warranty information

HPE ProLiant and x86 Servers and Options

(<http://www.hpe.com/support/ProLiantServers-Warranties>)

HPE Enterprise Servers (<http://www.hpe.com/support/EnterpriseServers-Warranties>)

HPE Storage Products (<http://www.hpe.com/support/Storage-Warranties>)

HPE Networking Products (<http://www.hpe.com/support/Networking-Warranties>)

Regulatory information

Safety and regulatory compliance

For important safety, environmental, and regulatory information, see *Safety and Compliance Information for Server, Storage, Power, Networking, and Rack Products*, available at the Hewlett Packard Enterprise website (<http://www.hpe.com/support/Safety-Compliance-EnterpriseProducts>).

Belarus Kazakhstan Russia marking



Manufacturer and Local Representative Information

Manufacturer information:

Hewlett Packard Enterprise Company, 3000 Hanover Street, Palo Alto, CA 94304 U.S.

Local representative information Russian:

- **Russia:**

ООО «Хьюлетт Паккард Энтерпрайз», Российская Федерация, 125171, г. Москва, Ленинградское шоссе, 16А, стр.3, Телефон/факс: +7 495 797 35 00

- **Belarus:**

ИООО «Хьюлетт-Паккард Бел», Республика Беларусь, 220030, г. Минск, ул. Интернациональная, 36-1, Телефон/факс: +375 17 392 28 18

- **Kazakhstan:**

ТОО «Хьюлетт-Паккард (К)», Республика Казахстан, 050040, г. Алматы, Бостандыкский район, проспект Аль-Фараби, 77/7, Телефон/факс: + 7 727 355 35 50

Local representative information Kazakh:

- **Russia:**

ЖШС "Хьюлетт Паккард Энтерпрайз" Ресей Федерациясы, 125171,
Мәскеу, Ленинград тас жолы, 16А блок 3, Телефон/факс: +7 495 797 35 00

- **Belarus:**

«HEWLETT-PACKARD Bel» ЖШС, Беларусь Республикасы, 220030, Минск қ.,
Интернациональная көшесі, 36/1, Телефон/факс: +375 17 392 28 18

- **Kazakhstan:**

ЖШС «Хьюлетт-Паккард (К)», Қазақстан Республикасы, 050040, Алматы қ.,
Бостандық ауданы, Әл-Фараби даңғылы, 77/7, Телефон/факс: +7 727 355 35 50

Manufacturing date:

The manufacturing date is defined by the serial number.

CCSYWWZZZZ (serial number format for this product)

Valid date formats include:

- YWW, where Y indicates the year counting from within each new decade, with 2000 as the starting point; for example, 238: 2 for 2002 and 38 for the week of September 9. In addition, 2010 is indicated by 0, 2011 by 1, 2012 by 2, 2013 by 3, and so forth.
- YYWW, where YY indicates the year, using a base year of 2000; for example, 0238: 02 for 2002 and 38 for the week of September 9.

Turkey RoHS material content declaration

Türkiye Cumhuriyeti: EEE Yönetmeliğine Uygundur

Ukraine RoHS material content declaration

Обладнання відповідає вимогам Технічного регламенту щодо обмеження використання деяких небезпечних речовин в електричному та електронному обладнанні, затвердженого постановою Кабінету Міністрів України від 3 грудня 2008 № 1057

Electrostatic discharge

Preventing electrostatic discharge

To prevent damaging the system, be aware of the precautions you must follow when setting up the system or handling parts. A discharge of static electricity from a finger or other conductor may damage system boards or other static-sensitive devices. This type of damage may reduce the life expectancy of the device.

To prevent electrostatic damage:

- Avoid hand contact by transporting and storing products in static-safe containers.
- Keep electrostatic-sensitive parts in their containers until they arrive at static-free workstations.
- Place parts on a grounded surface before removing them from their containers.
- Avoid touching pins, leads, or circuitry.
- Always be properly grounded when touching a static-sensitive component or assembly.

Grounding methods to prevent electrostatic discharge

Several methods are used for grounding. Use one or more of the following methods when handling or installing electrostatic-sensitive parts:

- Use a wrist strap connected by a ground cord to a grounded workstation or computer chassis. Wrist straps are flexible straps with a minimum of 1 megohm \pm 10 percent resistance in the ground cords. To provide proper ground, wear the strap snug against the skin.
- Use heel straps, toe straps, or boot straps at standing workstations. Wear the straps on both feet when standing on conductive floors or dissipating floor mats.
- Use conductive field service tools.
- Use a portable field service kit with a folding static-dissipating work mat.

If you do not have any of the suggested equipment for proper grounding, have an authorized reseller install the part.

For more information on static electricity or assistance with product installation, contact an authorized reseller.

Specifications

Environmental specifications

Specification	Value
Temperature range*	—
Operating	10°C to 35°C (50°F to 95°F)
Nonoperating	-30°C to 60°C (-22°F to 140°F)
Relative humidity (noncondensing)	—
Operating	Minimum to be the higher (more moisture) of -12°C (10.4°F) dew point or 8% relative humidity Maximum to be 24°C (75.2°F) dew point or 90% relative humidity
Nonoperating	5% to 95% 38.7°C (101.7°F), maximum wet bulb temperature

* All temperature ratings shown are for sea level. An altitude derating of 1.0°C per 304.8 m (1.8°F per 1000 ft) to 3048 m (10,000 ft) is applicable. No direct sunlight allowed. Maximum rate of change is 20°C per hour (36°F per hour). The upper limit and rate of change might be limited by the type and number of options installed.

For certain approved hardware configurations, the supported system inlet temperature range is extended:

- 5°C to 10°C (41°F to 50°F) and 35°C to 40°C (95°F to 104°F) at sea level with an altitude derating of 1.0°C per every 175 m (1.8°F per every 574 ft) above 900 m (2953 ft) to a maximum of 3048 m (10,000 ft).
- 40°C to 45°C (104°F to 113°F) at sea level with an altitude derating of 1.0°C per every 125 m (1.8°F per every 410 ft) above 900 m (2953 ft) to a maximum of 3048 m (10,000 ft).

The approved hardware configurations for this system are listed on the Hewlett Packard Enterprise website (<http://www.hpe.com/servers/ASHRAE>).

Server specifications

Specification	Value
Dimensions	
Rack model	—
Height	21.8 cm (8.58 in)
Depth	74.6cm
Width	44.5 cm (17.51 in)
Tower model	—
Height	46.4 cm (18.27 in)
Depth	76.9 cm (30.28 in)
Width	21.9 cm (8.62 in)
Weight	
Rack model	—

Specification	Value
Maximum	51 kg (112.4 lbs)
Minimum	26 kg (57.3 lbs)
Tower model	—
Maximum	55 kg (121.30 lbs)
Minimum	30 kg (66.14 lbs)

Power supply specifications

Depending on installed options, the server is configured with one of the following power supplies:

- HPE 500W Flex Slot Platinum Hot-plug Power Supply
- HPE 800W Flex Slot Platinum Hot-plug Power Supply
- HPE 800W Flex Slot Titanium Plus Hot-plug Power Supply
- HPE 800W Flex Slot Universal Hot-plug Power Supply
- HPE 800W Flex Slot -48VDC Hot-plug Power Supply
- HPE 1400W Flex Slot Platinum Plus Hot-plug Power Supply

For detailed power supply specifications, see the QuickSpecs on the Hewlett Packard Enterprise website (<http://www.hpe.com/info/proliant/powersupply>).

Hot-plug power supply calculations

For hot-plug power supply specifications and calculators to determine electrical and heat loading for the server, see the Hewlett Packard Enterprise Power Advisor website (<http://www.hpe.com/info/poweradvisor/online>).

Support and other resources

Accessing Hewlett Packard Enterprise Support

- For live assistance, go to the Contact Hewlett Packard Enterprise Worldwide website (<http://www.hpe.com/assistance>).
- To access documentation and support services, go to the Hewlett Packard Enterprise Support Center website (<http://www.hpe.com/support/hpesc>).

Information to collect

- Technical support registration number (if applicable)
- Product name, model or version, and serial number
- Operating system name and version
- Firmware version
- Error messages
- Product-specific reports and logs
- Add-on products or components
- Third-party products or components

Accessing updates

- Some software products provide a mechanism for accessing software updates through the product interface. Review your product documentation to identify the recommended software update method.
- To download product updates, go to either of the following:
 - Hewlett Packard Enterprise Support Center Get connected with updates page (<http://www.hpe.com/support/e-updates>)
 - Software Depot website (<http://www.hpe.com/support/softwaredepot>)
- To view and update your entitlements, and to link your contracts and warranties with your profile, go to the Hewlett Packard Enterprise Support Center More Information on Access to Support Materials page (<http://www.hpe.com/support/AccessToSupportMaterials>).



IMPORTANT: Access to some updates might require product entitlement when accessed through the Hewlett Packard Enterprise Support Center. You must have an HP Passport set up with relevant entitlements.

Websites

- Hewlett Packard Enterprise Information Library (<http://www.hpe.com/info/enterprise/docs>)
- Hewlett Packard Enterprise Support Center (<http://www.hpe.com/support/hpesc>)
- Contact Hewlett Packard Enterprise Worldwide (<http://www.hpe.com/assistance>)

- Subscription Service/Support Alerts (<http://www.hpe.com/support/e-updates>)
- Software Depot (<http://www.hpe.com/support/softwaredepot>)
- Customer Self Repair (<http://www.hpe.com/support/selfrepair>)
- Insight Remote Support (<http://www.hpe.com/info/insightremotesupport/docs>)
- Serviceguard Solutions for HP-UX (<http://www.hpe.com/info/hpux-serviceguard-docs>)
- Single Point of Connectivity Knowledge (SPOCK) Storage compatibility matrix (<http://www.hpe.com/storage/spock>)
- Storage white papers and analyst reports (<http://www.hpe.com/storage/whitepapers>)

Customer Self Repair

Hewlett Packard Enterprise products are designed with many Customer Self Repair (CSR) parts to minimize repair time and allow for greater flexibility in performing defective parts replacement. If during the diagnosis period Hewlett Packard Enterprise (or Hewlett Packard Enterprise service providers or service partners) identifies that the repair can be accomplished by the use of a CSR part, Hewlett Packard Enterprise will ship that part directly to you for replacement. There are two categories of CSR parts:

- **Mandatory**—Parts for which customer self repair is mandatory. If you request Hewlett Packard Enterprise to replace these parts, you will be charged for the travel and labor costs of this service.
- **Optional**—Parts for which customer self repair is optional. These parts are also designed for customer self repair. If, however, you require that Hewlett Packard Enterprise replace them for you, there may or may not be additional charges, depending on the type of warranty service designated for your product.

NOTE: Some Hewlett Packard Enterprise parts are not designed for customer self repair. In order to satisfy the customer warranty, Hewlett Packard Enterprise requires that an authorized service provider replace the part. These parts are identified as "No" in the Illustrated Parts Catalog.

Based on availability and where geography permits, CSR parts will be shipped for next business day delivery. Same day or four-hour delivery may be offered at an additional charge where geography permits. If assistance is required, you can call the Hewlett Packard Enterprise Support Center and a technician will help you over the telephone. Hewlett Packard Enterprise specifies in the materials shipped with a replacement CSR part whether a defective part must be returned to Hewlett Packard Enterprise. In cases where it is required to return the defective part to Hewlett Packard Enterprise, you must ship the defective part back to Hewlett Packard Enterprise within a defined period of time, normally five (5) business days. The defective part must be returned with the associated documentation in the provided shipping material. Failure to return the defective part may result in Hewlett Packard Enterprise billing you for the replacement. With a customer self repair, Hewlett Packard Enterprise will pay all shipping and part return costs and determine the courier/carrier to be used.

For more information about the Hewlett Packard Enterprise CSR program, contact your local service provider. For the North American program, go to the Hewlett Packard Enterprise CSR website (<http://www.hpe.com/support/selfrepair>).

Réparation par le client (CSR)

Les produits Hewlett Packard Enterprise comportent de nombreuses pièces CSR (Customer Self Repair = réparation par le client) afin de minimiser les délais de réparation et faciliter le remplacement des pièces défectueuses. Si pendant la période de diagnostic, Hewlett Packard Enterprise (ou ses partenaires ou mainteneurs agréés) détermine que la réparation peut être effectuée à l'aide d'une pièce CSR, Hewlett Packard Enterprise vous l'envoie directement. Il existe deux catégories de pièces CSR :

- **Obligatoire**—Pièces pour lesquelles la réparation par le client est obligatoire. Si vous demandez à Hewlett Packard Enterprise de remplacer ces pièces, les coûts de déplacement et main d'œuvre du service vous seront facturés.
- **Facultatif**—Pièces pour lesquelles la réparation par le client est facultative. Ces pièces sont également conçues pour permettre au client d'effectuer lui-même la réparation. Toutefois, si vous demandez à Hewlett Packard Enterprise de remplacer ces pièces, l'intervention peut ou non vous être facturée, selon le type de garantie applicable à votre produit.

REMARQUE: Certaines pièces Hewlett Packard Enterprise ne sont pas conçues pour permettre au client d'effectuer lui-même la réparation. Pour que la garantie puisse s'appliquer, Hewlett Packard Enterprise exige que le remplacement de la pièce soit effectué par un Mainteneur Agréé. Ces pièces sont identifiées par la mention "Non" dans le Catalogue illustré.

Les pièces CSR sont livrées le jour ouvré suivant, dans la limite des stocks disponibles et selon votre situation géographique. Si votre situation géographique le permet et que vous demandez une livraison le jour même ou dans les 4 heures, celle-ci vous sera facturée. Pour toute assistance, appelez le Centre d'assistance Hewlett Packard Enterprise pour qu'un technicien vous aide au téléphone. Dans les documents envoyés avec la pièce de rechange CSR, Hewlett Packard Enterprise précise s'il est nécessaire de lui retourner la pièce défectueuse. Si c'est le cas, vous devez le faire dans le délai indiqué, généralement cinq (5) jours ouvrés. La pièce et sa documentation doivent être retournées dans l'emballage fourni. Si vous ne retournez pas la pièce défectueuse, Hewlett Packard Enterprise se réserve le droit de vous facturer les coûts de remplacement. Dans le cas d'une pièce CSR, Hewlett Packard Enterprise supporte l'ensemble des frais d'expédition et de retour, et détermine la société de courses ou le transporteur à utiliser.

Pour plus d'informations sur le programme CSR de Hewlett Packard Enterprise, contactez votre Mainteneur Agréé local. Pour plus d'informations sur ce programme en Amérique du Nord, consultez le site Web Hewlett Packard Enterprise (<http://www.hpe.com/support/selfrepair>).

Riparazione da parte del cliente

Per abbreviare i tempi di riparazione e garantire una maggiore flessibilità nella sostituzione di parti difettose, i prodotti Hewlett Packard Enterprise sono realizzati con numerosi componenti che possono essere riparati direttamente dal cliente (CSR, Customer Self Repair). Se in fase di diagnostica Hewlett Packard Enterprise (o un centro di servizi o di assistenza Hewlett Packard Enterprise) identifica il guasto come riparabile mediante un ricambio CSR, Hewlett Packard Enterprise lo spedisce direttamente al cliente per la sostituzione. Vi sono due categorie di parti CSR:

- **Obbligatorie**—Parti che devono essere necessariamente riparate dal cliente. Se il cliente ne affida la riparazione ad Hewlett Packard Enterprise, deve sostenere le spese di spedizione e di manodopera per il servizio.
- **Opzionali**—Parti la cui riparazione da parte del cliente è facoltativa. Si tratta comunque di componenti progettati per questo scopo. Se tuttavia il cliente ne richiede la sostituzione ad Hewlett Packard Enterprise, potrebbe dover sostenere spese aggiuntive a seconda del tipo di garanzia previsto per il prodotto.

NOTA: alcuni componenti Hewlett Packard Enterprise non sono progettati per la riparazione da parte del cliente. Per rispettare la garanzia, Hewlett Packard Enterprise richiede che queste parti siano sostituite da un centro di assistenza autorizzato. Tali parti sono identificate da un "No" nel Catalogo illustrato dei componenti.

In base alla disponibilità e alla località geografica, le parti CSR vengono spedite con consegna entro il giorno lavorativo seguente. La consegna nel giorno stesso o entro quattro ore è offerta con un supplemento di costo solo in alcune zone. In caso di necessità si può richiedere l'assistenza telefonica di un addetto del centro di supporto tecnico Hewlett Packard Enterprise. Nel materiale fornito con una parte di ricambio CSR, Hewlett Packard Enterprise specifica se il cliente deve restituire dei componenti. Qualora sia richiesta la resa ad Hewlett Packard Enterprise del componente difettoso, lo si deve spedire ad Hewlett Packard Enterprise entro un determinato periodo di tempo, generalmente cinque (5) giorni lavorativi. Il componente difettoso deve essere restituito con la documentazione associata nell'imballo di

spedizione fornito. La mancata restituzione del componente può comportare la fatturazione del ricambio da parte di Hewlett Packard Enterprise. Nel caso di riparazione da parte del cliente, Hewlett Packard Enterprise sostiene tutte le spese di spedizione e resa e sceglie il corriere/vettore da utilizzare.

Per ulteriori informazioni sul programma CSR di Hewlett Packard Enterprise, contattare il centro di assistenza di zona. Per il programma in Nord America fare riferimento al sito Web (<http://www.hpe.com/support/selfrepair>).

Customer Self Repair

Hewlett Packard Enterprise Produkte enthalten viele CSR-Teile (Customer Self Repair), um Reparaturzeiten zu minimieren und höhere Flexibilität beim Austausch defekter Bauteile zu ermöglichen. Wenn Hewlett Packard Enterprise (oder ein Hewlett Packard Enterprise Servicepartner) bei der Diagnose feststellt, dass das Produkt mithilfe eines CSR-Teils repariert werden kann, sendet Ihnen Hewlett Packard Enterprise dieses Bauteil zum Austausch direkt zu. CSR-Teile werden in zwei Kategorien unterteilt:

- **Zwingend**—Teile, für die das Customer Self Repair-Verfahren zwingend vorgegeben ist. Wenn Sie den Austausch dieser Teile von Hewlett Packard Enterprise vornehmen lassen, werden Ihnen die Anfahrt- und Arbeitskosten für diesen Service berechnet.
- **Optional**—Teile, für die das Customer Self Repair-Verfahren optional ist. Diese Teile sind auch für Customer Self Repair ausgelegt. Wenn Sie jedoch den Austausch dieser Teile von Hewlett Packard Enterprise vornehmen lassen möchten, können bei diesem Service je nach den für Ihr Produkt vorgesehenen Garantiebedingungen zusätzliche Kosten anfallen.

HINWEIS: Einige Hewlett Packard Enterprise Teile sind nicht für Customer Self Repair ausgelegt. Um den Garantieanspruch des Kunden zu erfüllen, muss das Teil von einem Hewlett Packard Enterprise Servicepartner ersetzt werden. Im illustrierten Teilekatalog sind diese Teile mit „No“ bzw. „Nein“ gekennzeichnet.

CSR-Teile werden abhängig von der Verfügbarkeit und vom Lieferziel am folgenden Geschäftstag geliefert. Für bestimmte Standorte ist eine Lieferung am selben Tag oder innerhalb von vier Stunden gegen einen Aufpreis verfügbar. Wenn Sie Hilfe benötigen, können Sie das Hewlett Packard Enterprise Support Center anrufen und sich von einem Mitarbeiter per Telefon helfen lassen. Den Materialien von Hewlett Packard Enterprise, die mit einem CSR-Ersatzteil geliefert werden, können Sie entnehmen, ob das defekte Teil an Hewlett Packard Enterprise zurückgeschickt werden muss. Wenn es erforderlich ist, das defekte Teil an Hewlett Packard Enterprise zurückzuschicken, müssen Sie dies innerhalb eines vorgegebenen Zeitraums tun, in der Regel innerhalb von fünf (5) Geschäftstagen. Das defekte Teil muss mit der zugehörigen Dokumentation in der Verpackung zurückgeschickt werden, die im Lieferumfang enthalten ist. Wenn Sie das defekte Teil nicht zurückschicken, kann Hewlett Packard Enterprise Ihnen das Ersatzteil in Rechnung stellen. Im Falle von Customer Self Repair kommt Hewlett Packard Enterprise für alle Kosten für die Lieferung und Rücksendung auf und bestimmt den Kurier-/Frachtdienst.

Weitere Informationen über das Hewlett Packard Enterprise Customer Self Repair Programm erhalten Sie von Ihrem Servicepartner vor Ort. Informationen über das CSR-Programm in Nordamerika finden Sie auf der Hewlett Packard Enterprise Website unter (<http://www.hpe.com/support/selfrepair>).

Reparaciones del propio cliente

Los productos de Hewlett Packard Enterprise incluyen muchos componentes que el propio usuario puede reemplazar (Customer Self Repair, CSR) para minimizar el tiempo de reparación y ofrecer una mayor flexibilidad a la hora de realizar sustituciones de componentes defectuosos. Si, durante la fase de diagnóstico, Hewlett Packard Enterprise (o los proveedores o socios de servicio de Hewlett Packard Enterprise) identifica que una reparación puede llevarse a cabo mediante el uso de un componente CSR, Hewlett Packard Enterprise le enviará dicho componente directamente para que realice su sustitución. Los componentes CSR se clasifican en dos categorías:

- **Obligatorio**—componentes cuya reparación por parte del usuario es obligatoria. Si solicita a Hewlett Packard Enterprise que realice la sustitución de estos componentes, tendrá que hacerse cargo de los gastos de desplazamiento y de mano de obra de dicho servicio.
- **Opcional**—componentes cuya reparación por parte del usuario es opcional. Estos componentes también están diseñados para que puedan ser reparados por el usuario. Sin embargo, si precisa que Hewlett Packard Enterprise realice su sustitución, puede o no conllevar costes adicionales, dependiendo del tipo de servicio de garantía correspondiente al producto.

NOTA: Algunos componentes de Hewlett Packard Enterprise no están diseñados para que puedan ser reparados por el usuario. Para que el usuario haga valer su garantía, Hewlett Packard Enterprise pone como condición que un proveedor de servicios autorizado realice la sustitución de estos componentes. Dichos componentes se identifican con la palabra "No" en el catálogo ilustrado de componentes.

Según la disponibilidad y la situación geográfica, los componentes CSR se enviarán para que lleguen a su destino al siguiente día laborable. Si la situación geográfica lo permite, se puede solicitar la entrega en el mismo día o en cuatro horas con un coste adicional. Si precisa asistencia técnica, puede llamar al Centro de asistencia técnica de Hewlett Packard Enterprise y recibirá ayuda telefónica por parte de un técnico. Con el envío de materiales para la sustitución de componentes CSR, Hewlett Packard Enterprise especificará si los componentes defectuosos deberán devolverse a Hewlett Packard Enterprise. En aquellos casos en los que sea necesario devolver algún componente a Hewlett Packard Enterprise, deberá hacerlo en el periodo de tiempo especificado, normalmente cinco días laborables. Los componentes defectuosos deberán devolverse con toda la documentación relacionada y con el embalaje de envío. Si no enviara el componente defectuoso requerido, Hewlett Packard Enterprise podrá cobrarle por el de sustitución. En el caso de todas sustituciones que lleve a cabo el cliente, Hewlett Packard Enterprise se hará cargo de todos los gastos de envío y devolución de componentes y escogerá la empresa de transporte que se utilice para dicho servicio.

Para obtener más información acerca del programa de Reparaciones del propio cliente de Hewlett Packard Enterprise, póngase en contacto con su proveedor de servicios local. Si está interesado en el programa para Norteamérica, visite la página web de Hewlett Packard Enterprise CSR (<http://www.hpe.com/support/selfrepair>).

Customer Self Repair

Veel onderdelen in Hewlett Packard Enterprise producten zijn door de klant zelf te repareren, waardoor de reparatieduur tot een minimum beperkt kan blijven en de flexibiliteit in het vervangen van defecte onderdelen groter is. Deze onderdelen worden CSR-onderdelen (Customer Self Repair) genoemd. Als Hewlett Packard Enterprise (of een Hewlett Packard Enterprise Service Partner) bij de diagnose vaststelt dat de reparatie kan worden uitgevoerd met een CSR-onderdeel, verzendt Hewlett Packard Enterprise dat onderdeel rechtstreeks naar u, zodat u het defecte onderdeel daarmee kunt vervangen. Er zijn twee categorieën CSR-onderdelen:

- **Verplicht**—Onderdelen waarvoor reparatie door de klant verplicht is. Als u Hewlett Packard Enterprise verzoekt deze onderdelen voor u te vervangen, worden u voor deze service reiskosten en arbeidsloon in rekening gebracht.
- **Optioneel**—Onderdelen waarvoor reparatie door de klant optioneel is. Ook deze onderdelen zijn ontworpen voor reparatie door de klant. Als u echter Hewlett Packard Enterprise verzoekt deze onderdelen voor u te vervangen, kunnen daarvoor extra kosten in rekening worden gebracht, afhankelijk van het type garantieservice voor het product.

OPMERKING: Sommige Hewlett Packard Enterprise onderdelen zijn niet ontwikkeld voor reparatie door de klant. In verband met de garanti voorwaarden moet het onderdeel door een geautoriseerde Service Partner worden vervangen. Deze onderdelen worden in de geïllustreerde onderdelencatalogus aangemerkt met "Nee".

Afhankelijk van de leverbaarheid en de locatie worden CSR-onderdelen verzonden voor levering op de eerstvolgende werkdag. Levering op dezelfde dag of binnen vier uur kan tegen meerkosten worden aangeboden, indien dit mogelijk is gezien de locatie. Indien assistentie is gewenst, belt u het Hewlett Packard Enterprise Support Center om via de telefoon ondersteuning van een technicus te ontvangen.

Hewlett Packard Enterprise vermeldt in de documentatie bij het vervangende CSR-onderdeel of het defecte onderdeel aan Hewlett Packard Enterprise moet worden geretourneerd. Als het defecte onderdeel aan Hewlett Packard Enterprise moet worden teruggezonden, moet u het defecte onderdeel binnen een bepaalde periode, gewoonlijk vijf (5) werkdagen, retourneren aan Hewlett Packard Enterprise. Het defecte onderdeel moet met de bijbehorende documentatie worden geretourneerd in het meegeleverde verpakkingsmateriaal. Als u het defecte onderdeel niet terugzendt, kan Hewlett Packard Enterprise u voor het vervangende onderdeel kosten in rekening brengen. Bij reparatie door de klant betaalt Hewlett Packard Enterprise alle verzendkosten voor het vervangende en geretourneerde onderdeel en kiest Hewlett Packard Enterprise zelf welke koerier/transportonderneming hiervoor wordt gebruikt.

Neem contact op met een Service Partner voor meer informatie over het Customer Self Repair programma van Hewlett Packard Enterprise. Informatie over Service Partners vindt u op de Hewlett Packard Enterprise website (<http://www.hpe.com/support/selfrepair>).

Reparo feito pelo cliente

Os produtos da Hewlett Packard Enterprise são projetados com muitas peças para reparo feito pelo cliente (CSR) de modo a minimizar o tempo de reparo e permitir maior flexibilidade na substituição de peças com defeito. Se, durante o período de diagnóstico, a Hewlett Packard Enterprise (ou fornecedores/parceiros da Hewlett Packard Enterprise) concluir que o reparo pode ser efetuado pelo uso de uma peça CSR, a Hewlett Packard Enterprise enviará a peça diretamente ao cliente. Há duas categorias de peças CSR:

- **Obrigatória**—Peças cujo reparo feito pelo cliente é obrigatório. Se desejar que a Hewlett Packard Enterprise substitua essas peças, serão cobradas as despesas de transporte e mão-de-obra do serviço.
- **Opcional**—Peças cujo reparo feito pelo cliente é opcional. Essas peças também são projetadas para o reparo feito pelo cliente. No entanto, se desejar que a Hewlett Packard Enterprise as substitua, pode haver ou não a cobrança de taxa adicional, dependendo do tipo de serviço de garantia destinado ao produto.

OBSERVAÇÃO: Algumas peças da Hewlett Packard Enterprise não são projetadas para o reparo feito pelo cliente. A fim de cumprir a garantia do cliente, a Hewlett Packard Enterprise exige que um técnico autorizado substitua a peça. Essas peças estão identificadas com a marca "No" (Não), no catálogo de peças ilustrado.

Conforme a disponibilidade e o local geográfico, as peças CSR serão enviadas no primeiro dia útil após o pedido. Onde as condições geográficas permitirem, a entrega no mesmo dia ou em quatro horas pode ser feita mediante uma taxa adicional. Se precisar de auxílio, entre em contato com o Centro de suporte técnico da Hewlett Packard Enterprise para que um técnico o ajude por telefone. A Hewlett Packard Enterprise especifica nos materiais fornecidos com a peça CSR de reposição se a peça com defeito deve ser devolvida à Hewlett Packard Enterprise. Nos casos em que isso for necessário, é preciso enviar a peça com defeito à Hewlett Packard Enterprise, você deverá enviar a peça com defeito de volta para a Hewlett Packard Enterprise dentro do período de tempo definido, normalmente em 5 (cinco) dias úteis. A peça com defeito deve ser enviada com a documentação correspondente no material de transporte fornecido. Caso não o faça, a Hewlett Packard Enterprise poderá cobrar a reposição. Para as peças de reparo feito pelo cliente, a Hewlett Packard Enterprise paga todas as despesas de transporte e de devolução da peça e determina a transportadora/serviço postal a ser utilizado.

Para obter mais informações sobre o programa de reparo feito pelo cliente da Hewlett Packard Enterprise, entre em contato com o fornecedor de serviços local. Para o programa norte-americano, visite o site da Hewlett Packard Enterprise (<http://www.hpe.com/support/selfrepair>).

カスタマーセルフリペア

修理時間を短縮し、故障部品の交換における高い柔軟性を確保するために、Hewlett Packard Enterprise製品には多数のカスタマーセルフリペア（CSR）部品があります。診断の際に、CSR部品を使用すれば修理ができるとHewlett Packard Enterprise（Hewlett Packard EnterpriseまたはHewlett Packard Enterprise正規保守代理店）が判断した場合、Hewlett Packard Enterpriseはその部品を直接、お客様に発送し、お客様に交換していただきます。CSR部品には以下の2種類があります。

- **必須** - カスタマーセルフリペアが必須の部品。当該部品について、もしもお客様がHewlett Packard Enterpriseに交換作業を依頼される場合には、その修理サービスに関する交通費および人件費がお客様に請求されます。
- **任意** - カスタマーセルフリペアが任意である部品。この部品もカスタマーセルフリペア用です。当該部品について、もしもお客様がHewlett Packard Enterpriseに交換作業を依頼される場合には、お買い上げの製品に適用される保証サービス内容の範囲内においては、別途費用を負担していただくことなく保証サービスを受けることができます。

注：Hewlett Packard Enterprise製品の一部の部品は、カスタマーセルフリペアの対象外です。製品の保証を継続するためには、Hewlett Packard EnterpriseまたはHewlett Packard Enterprise正規保守代理店による交換作業が必須となります。部品カタログには、当該部品がカスタマーセルフリペア除外品である旨が記載されています。

部品供給が可能な場合、地域によっては、CSR部品を翌営業日に届くように発送します。また、地域によっては、追加費用を負担いただくことにより同日または4時間以内に届くように発送することも可能な場合があります。サポートが必要なときは、Hewlett Packard Enterpriseの修理受付窓口に電話していただければ、技術者が電話でアドバイスします。交換用のCSR部品または同梱物には、故障部品をHewlett Packard Enterpriseに返送する必要があるかどうかが表示されています。故障部品をHewlett Packard Enterpriseに返送する必要がある場合は、指定期限内（通常は5営業日以内）に故障部品をHewlett Packard Enterpriseに返送してください。故障部品を返送する場合は、届いた時の梱包箱に関連書類とともにに入れてください。故障部品を返送しない場合、Hewlett Packard Enterpriseから部品費用が請求されます。カスタマーセルフリペアの際には、Hewlett Packard Enterpriseは送料および部品返送費を全額負担し、使用する宅配便会社や運送会社を指定します。

客户自行维修

Hewlett Packard Enterprise 产品提供许多客户自行维修 (CSR) 部件，以尽可能缩短维修时间和在更换缺陷部件方面提供更大的灵活性。如果在诊断期间 Hewlett Packard Enterprise (或 Hewlett Packard Enterprise 服务提供商或服务合作伙伴) 确定可以通过使用 CSR 部件完成维修，Hewlett Packard Enterprise 将直接把该部件发送给您进行更换。有两类 CSR 部件：

- **强制性的** — 要求客户必须自行维修的部件。如果您请求 Hewlett Packard Enterprise 更换这些部件，则必须为该服务支付差旅费和人工费用。
- **可选的** — 客户可以选择是否自行维修的部件。这些部件也是为客户自行维修设计的。不过，如果您要求 Hewlett Packard Enterprise 为您更换这些部件，则根据为您的产品指定的保修服务类型，Hewlett Packard Enterprise 可能收取或不再收取任何附加费用。

注：某些 Hewlett Packard Enterprise 部件的设计并未考虑客户自行维修。为了满足客户保修的需要，Hewlett Packard Enterprise 要求授权服务提供商更换相关部件。这些部件在部件图解目录中标记为“否”。

CSR 部件将在下一个工作日发运（取决于备货情况和允许的地理范围）。在允许的地理范围内，可在当天或四小时内发运，但要收取额外费用。如果需要帮助，您可以致电 Hewlett Packard Enterprise 技术支持中心，将会有技术人员通过电话为您提供帮助。Hewlett Packard Enterprise 会在随更换的 CSR 部件发运的材料中指明是否必须将有缺陷的部件返还给 Hewlett Packard Enterprise。如果要求您将有缺陷的部件返还给 Hewlett Packard Enterprise，那么您必须在规定的期限内（通常是五 (5) 个工作日）将缺陷部件发给 Hewlett Packard Enterprise。有缺陷的部件必须随所提供的发运材料中的相关文件一起返还。如果未能送还有缺陷的部件，Hewlett Packard Enterprise 可能会要求您支付更换费用。客户自行维修时，Hewlett Packard Enterprise 将承担所有相关运输和部件返回费用，并指定快递商/承运商。

有关 Hewlett Packard Enterprise 客户自行维修计划的详细信息，请与您当地的服务提供商联系。有关北美地区的计划，请访问 Hewlett Packard Enterprise 网站 (<http://www.hpe.com/support/selfrepair>)。

客戶自行維修

Hewlett Packard Enterprise 產品設計了許多「客戶自行維修」(CSR) 的零件以減少維修時間，並且使得更換瑕疵零件時能有更大的彈性。如果在診斷期間，Hewlett Packard Enterprise (或 Hewlett Packard Enterprise 服務供應商或維修夥伴) 辨認出此項維修工作可以藉由使用 CSR 零件來完成，則 Hewlett Packard Enterprise 將直接寄送該零件給您作更換。CSR 零件分為兩種類別：

- **強制的** — 客戶自行維修所使用的零件是強制的。如果您要求 Hewlett Packard Enterprise 更換這些零件，Hewlett Packard Enterprise 將會向您收取此服務所需的外出費用與勞動成本。
- **選購的** — 客戶自行維修所使用的零件是選購的。這些零件也設計用於客戶自行維修之用。不過，如果您要求 Hewlett Packard Enterprise 為您更換，則可能需要也可能不需要負擔額外的費用，端視針對此產品指定的保固服務類型而定。

備註：某些 Hewlett Packard Enterprise 零件沒有消費者可自行維修的設計。為符合客戶保固，Hewlett Packard Enterprise 需要授權的服務供應商更換零件。這些零件在圖示的零件目錄中，被標示為「否」。

基於材料取得及環境允許的情況下，CSR 零件將於下一個工作日以快遞寄送。在環境的允許下當天或四小時內送達，則可能需要額外的費用。若您需要協助，可致電 Hewlett Packard Enterprise 支援中心，會有一位技術人員透過電話來協助您。不論損壞的零件是否必須退回，Hewlett Packard Enterprise 皆會在與 CSR 替換零件一起運送的材料中註明。若要將損壞的零件退回 Hewlett Packard Enterprise，您必須在指定的一段時間內（通常為五 (5) 個工作天），將損壞的零件寄回 Hewlett Packard Enterprise。損壞的零件必須與寄送資料中隨附的相關技術文件一併退還。如果無法退還損壞的零件，Hewlett Packard Enterprise 可能要向您收取替換費用。針對客戶自行維修情形，Hewlett Packard Enterprise 將負責所有運費及零件退還費用，並指定使用何家快遞/貨運公司。

如需 Hewlett Packard Enterprise 的 CSR 方案詳細資訊，請連絡您當地的服務供應商。至於北美方案，請參閱 Hewlett Packard Enterprise 的 CSR 網站 [selfrepair](http://www.hpe.com/support/selfrepair) (<http://www.hpe.com/support/selfrepair>)。

고객 셀프 수리

Hewlett Packard Enterprise 제품은 수리 시간을 최소화하고 결함이 있는 부품 교체 시 더욱 융통성을 발휘할 수 있도록 하기 위해 고객 셀프 수리(CSR) 부품을 다량 사용하여 설계되었습니다. 진단 기간 동안 Hewlett Packard Enterprise(또는 Hewlett Packard Enterprise 서비스 공급업체 또는 서비스 협력업체)에서 CSR 부품을 사용하여 수리가 가능하다고 판단되면 Hewlett Packard Enterprise는 해당 부품을 바로 사용자에게 보내어 사용자가 교체할 수 있도록 합니다. CSR 부품에는 두 가지 종류가 있습니다.

- 필수 - 고객 셀프 수리가 의무 사항인 필수 부품. 사용자가 Hewlett Packard Enterprise에 이 부품의 교체를 요청할 경우 이 서비스에 대한 출장비 및 작업비가 청구됩니다.
- 선택 사항 - 고객 셀프 수리가 선택 사항인 부품. 이 부품들도 고객 셀프 수리가 가능하도록 설계되었습니다. 하지만 사용자가 Hewlett Packard Enterprise에 이 부품의 교체를 요청할 경우 사용자가 구입한 제품에 해당하는 보증 서비스 유형에 따라 추가 비용 없이 교체가 가능할 수 있습니다.

참고: 일부 Hewlett Packard Enterprise 부품은 고객 셀프 수리가 불가능하도록 설계되었습니다. Hewlett Packard Enterprise는 만족스러운 고객 보증을 위해 공인 서비스 제공업체를 통해 부품을 교체하도록 하고 있습니다. 이러한 부품들은 Illustrated Parts Catalog에 “No”라고 표시되어 있습니다.

CSR 부품은 재고 상태와 지리적 조건이 허용하는 경우 다음 영업일 납품이 가능하도록 배송이 이루어집니다. 지리적 조건이 허용하는 경우 추가 비용이 청구되는 조건으로 당일 또는 4시간 배송이 가능할 수도 있습니다. 도움이 필요하시면 Hewlett Packard Enterprise Support Center로 전화하십시오. 전문 기술자가 전화로 도움을 줄 것입니다. Hewlett Packard Enterprise는 결함이 발생한 부품을 Hewlett Packard Enterprise로 반환해야 하는지 여부를 CSR 교체 부품과 함께 배송된 자료에 지정합니다. 결함이 발생한 부품을 Hewlett Packard Enterprise로 반환해야 하는 경우에는 지정된 기간 내(통상 영업일 기준 5일)에 Hewlett Packard Enterprise로 반환해야 합니다. 이때 결함이 발생한 부품은 제공된 포장 재료에 넣어 관련 설명서와 함께 반환해야 합니다. 결함이 발생한 부품을 반환하지 않는 경우 Hewlett Packard Enterprise가 교체 부품에 대해 비용을 청구할 수 있습니다. 고객 셀프 수리의 경우, Hewlett Packard Enterprise는 모든 운송 및 부품 반환 비용을 부담하며 이용할 운송업체 및 택배 서비스를 결정합니다.

Hewlett Packard Enterprise CSR 프로그램에 대한 자세한 내용은 가까운 서비스 제공업체에 문의하십시오. 북미 지역의 프로그램에 대해서는 Hewlett Packard Enterprise CSR 웹 사이트(<http://www.hpe.com/support/selfrepair>)를 참조하십시오.

Remote support

Remote support is available with supported devices as part of your warranty or contractual support agreement. It provides intelligent event diagnosis, and automatic, secure submission of hardware event notifications to Hewlett Packard Enterprise, which will initiate a fast and accurate resolution based on your product's service level. Hewlett Packard Enterprise strongly recommends that you register your device for remote support.

If your product includes additional remote support details, use search to locate that information.

Remote support and Proactive Care information

HPE Get Connected (<http://www.hpe.com/services/getconnected>)

HPE Proactive Care services (<http://www.hpe.com/services/proactivecare>)

HPE Proactive Care service: Supported products list

(<http://www.hpe.com/services/proactivecaresupportedproducts>)

HPE Proactive Care advanced service: Supported products list

(<http://www.hpe.com/services/proactivecareadvancedsupportedproducts>)

Proactive Care customer information

Proactive Care central (<http://www.hpe.com/services/proactivecarecentral>)

Proactive Care service activation (<http://www.hpe.com/services/proactivecarecentralgetstarted>)

Acronyms and abbreviations

ABEND

abnormal end

ACU

Array Configuration Utility

AMP

Advanced Memory Protection

API

application program interface

ASHRAE

American Society of Heating, Refrigerating and Air-Conditioning Engineers

ASR

Automatic Server Recovery

BP

backplane

CAS

column address strobe

CSA

Canadian Standards Association

CSR

Customer Self Repair

DDR3

double data rate-3

DDR4

double data rate-4

FAT

file allocation table

FBWC

flash-backed write cache

GPU

graphics processing unit

HBA

host bus adapter

HP SUM

HP Smart Update Manager

HPE SSA

HPE Smart Storage Administrator

IEC

International Electrotechnical Commission

iLO

Integrated Lights-Out

IML

Integrated Management Log

ISO

International Organization for Standardization

JSON

JavaScript Object Notation

LFF

large form factor

LOM

Lights-Out Management

LRDIMM

load reduced dual in-line memory module

NAND

Not AND

NMI

nonmaskable interrupt

NVDIMM

non-volatile dual in-line memory module

NVMe

non-volatile memory express

NVRAM

nonvolatile memory

OA

Onboard Administrator

ODD

Optical Disk Drive

PCIe

Peripheral Component Interconnect Express

PDU

power distribution unit

POST

Power-On Self-Test

QR code

quick response code

RBSU

ROM-Based Setup Utility

RDIMM

registered dual in-line memory module

RDP

Rapid Deployment Pack

REST

representational state transfer

RoHS

Restriction of Hazardous Substances

RPS

redundant power supply

SAS

serial attached SCSI

SATA

serial ATA

SD

Secure Digital

SFF

small form factor

SIM

Systems Insight Manager

SPP

Service Pack for ProLiant

SSD

solid-state drive

STD

standard (DIMM voltage)

TDP

Thermal Design Power

TMRA

recommended ambient operating temperature

TPM

Trusted Platform Module

UEFI

Unified Extensible Firmware Interface

UID

unit identification

USB

universal serial bus

VC

Virtual Connect

VCA

Version Control Agent

VCRM

Version Control Repository Manager

Documentation feedback

Hewlett Packard Enterprise is committed to providing documentation that meets your needs. To help us improve the documentation, send any errors, suggestions, or comments to Documentation Feedback (<mailto:docsfeedback@hpe.com>). When submitting your feedback, include the document title, part number, edition, and publication date located on the front cover of the document. For online help content, include the product name, product version, help edition, and publication date located on the legal notices page.

Index

A

access panel 32, 33
Accessing updates 173
Active Health System 150, 151
Advanced ECC memory 101, 102
air baffle 34, 35
air baffle, removing 34
airflow requirements 43
ASR (Automatic Server Recovery) 158
authorized reseller 170, 173
authorized technician 174

B

backplane power connector 18
Basic Input/Output System (BIOS) 150
battery 165
battery replacement notice 168
before you contact Hewlett Packard Enterprise 173
Belarus Kazakhstan Russia marking 168
bezel 31, 50
BIOS (Basic Input/Output System) 150
boot options 48, 154, 155, 157
BSMI notice 168
buttons 7, 11

C

cables 134
cabling 134
Canadian notice 168
Care Pack 163, 173
cautions 170
Change Control 154, 155, 163
change control and proactive notification 163
compliance 168
components 7
configuration settings 156
connectors 7
contacting Hewlett Packard Enterprise 173
controller options 62
CSR (customer self repair) 174
customer self repair (CSR) 174

D

DC power supply 45
Declaration of Conformity 168, 169
device numbers 19
diagnosing problems 164

diagnostic tools 150, 153, 155, 157, 158
diagnostics utility 153
DIMM installation guidelines 100
DIMM population guidelines 102
DIMM slots 17
DIMMs 100
disposal, battery 168
documentation feedback 187
downloading files 173
drive 58, 60
drive blank 59
drive cage, installing 116
drive LEDs 26
drive numbering 19
drivers 161
drives, determining status of 26
drives, installation guidelines 58

E

Eight-bay SFF drive cage 116
electrical grounding requirements 45
electrostatic discharge 170
embedded UEFI diagnostics 157
embedded UEFI shell 156
environmental requirements 43
Erase Utility 150, 153
error messages 164
EuroAsian Economic Commission 168
European Union notice 168
extend server from rack 34
external USB functionality 158

F

fan cage 37, 38
fan, removing 36, 43
features 7, 157
Federal Communications Commission (FCC)
notice 168
firmware update 154, 160, 161, 162
firmware upgrade utility, troubleshooting 164
firmware, updating 154, 162
firmware, upgrading 162
flexible boot control 155
front panel components 7
front panel LEDs 10

G

graphic card option 111
grounding methods 170

grounding requirements 45, 170

H

hard drive LEDs 26
hard drives, determining status of 26
hardware options 50
hardware options installation 47, 50
health driver 158
help resources 173
Hewlett Packard Enterprise contact information 173
Hewlett Packard Enterprise Technical Support 163, 173, 181
Hewlett Packard Enterprise website 173
Hewlett Packard Enterprise, contacting 173
host bus adapter 65
hot-plug drive 59
hot-plug fans 28
HP Smart Update Manager overview 154
HPE Dual 8Gb microSD USB device 123
HPE Flexible Smart Array Controller 144
HPE Insight Remote Support software 163
HPE Smart Array controller 69, 144
HPE Smart Storage Administrator (HPE SSA) 157
HPE Smart Storage Battery 74
HPE SmartMemory 99

I

identifying components 7
iLO 150, 151
iLO (Integrated Lights-Out) 150, 151, 152
IML (Integrated Management Log) 150, 152
Information to collect 173
Insight Diagnostics 150, 152, 153, 160
Insight Diagnostics survey functionality 153
installation services 43
installing the server into the rack 48
Integrated Lights-Out (iLO) 151, 152
Integrated Management Log (IML) 150, 152
Intelligent Provisioning 150, 152, 153, 154, 155
internal cables 134

J

Japanese notice 168

L

LEDs, drive 26
LEDs, hard drive 26
LEDs, rear panel 12
LFF backplane 119
LFF drive cage 119

M

M.2 SSD enablement board 121
M.2 SSD enablement option 121

maintenance guidelines 160
media bay blank 39
media cage 104, 108
memory 97, 100, 101, 102
memory configurations 101
memory options 97
memory subsystem architecture 99, 100
memory, Advanced ECC 101
memory, online spare 101, 102
microSD card 123
mirrored memory 102, 103
modifications, FCC notice 168

N

NIC activity LED 12
NIC connectors 11
NIC link LED 12
NMI functionality 16
NVMe SSD 27, 60

O

online spare memory 101, 102
operating system installation 163
operating system version support 162, 163
operating systems 162, 163
operating systems supported 153, 162, 163
optical drive 39, 87
optimum environment 43
options installation 47, 50

P

passwords 133
phone numbers 173
population guidelines, mirrored memory 103
population order, memory 102
power distribution unit (PDU) 45
power requirements 44
power supply 124, 172
power supply backplane 125
power supply, hot-plug 124, 172
powering down 30
powering up 30
preparation procedures 30
proactive notification 163
problem diagnosis 164
processor option 90
processor, installing 91
Product ID 157

Q

QuickSpecs 50, 100, 130

R

rear panel components 11

- rear panel LEDs 12
- recovery key 133
- redundant fan 95
- redundant ROM 159
- registering the server 49
- regulatory compliance information 168
- regulatory compliance notices 168, 169
- remote support 181
- resources 173
- RESTful API 151, 157
- ROM redundancy 159
- ROM-Based Setup Utility (RBSU) 130, 154
- ROMPaq utility 159

S

- safety and regulatory compliance 168
- safety considerations 168, 170
- safety information 159, 168
- SAS expander 76, 80, 83
- scripted installation 153
- scripting toolkit 150, 153
- secure boot configuration 156
- security bezel, removing 31
- serial number 157
- server features and options 50
- Server mode 150
- server specifications 171
- Service Pack for ProLiant 150, 153, 154
- setup 43
- SFF drive cage 116
- shipping carton contents 46
- site requirements 43
- Smart Storage Battery 139
- Smart Update Manager 150, 154
- software 150, 162, 163
- software upgrades 162
- space requirements 43
- specifications, server 171
- SSD, installing 122
- static electricity 170
- storage controller 58, 62
- support and other resources 173
- supported operating systems 162, 163
- system battery 165
- system board components 15
- system components 7
- system configuration settings 17, 159
- system maintenance switch 17
- system, keeping current 160
- Systems Insight Display 13, 14, 41, 56
- Systems Insight Display LED combinations 14
- Systems Insight Display LEDs 13

T

- Taiwan battery recycling notice 168
- technical support 163, 173

- telephone numbers 173
- temperature 44
- temperature requirements 44, 171
- tower bezel, installing 31
- tower bezel, removing 31
- tower server, setting up 47
- tower-to-rack conversion 50
- TPM (Trusted Platform Module) 130, 133
- troubleshooting 164
- troubleshooting resources 164
- troubleshooting, firmware upgrade utility 164
- Trusted Platform Module (TPM) 130, 131, 133

U

- UEFI System Utilities 154, 155
- UEFI, boot mode 48, 155
- updating the system ROM 159, 160, 161
- UPS (uninterruptible power supply) 44
- USB devices 123
- USB support 158
- utilities 150, 154, 155, 157
- utilities, deployment 150, 153

V

- ventilation 43
- Version Control 162
- Version Control Agent (VCA) 162
- Version Control Repository Manager (VCRM) 162

W

- warranty information 168
- website, Hewlett Packard Enterprise 173